



Neo

DUCTLESS SYSTEM

Installation, Service & Troubleshooting

Models:

NEO09HP115V1A

NEO12HP115V1A

NEO09HP230V1A

NEO12HP230V1A

NEO18HP230V1A

NEO24HP230V1A

NEO30HP230V1A

NEO36HP230V1A

Table of Contents

Safety Precautions & Warnings.....	4
Model Number Identification.....	5
Physical & Electrical Data.....	6 - 9
System Overview.....	10
Refrigeration Cycles and Components.....	11 - 15
Indoor & Outdoor Components.....	16 - 18
Basic & Protection Functions.....	19 -52
Remote Control Operation.....	53 - 57
Refrigerant Lines, Connection, Evacuating and Charging.....	58 - 66
Installation, Filter Maintenance and Emergency Operation.....	67
Electrical Schematics.....	68 - 79
Outdoor Printed Circuit Board.....	80
Troubleshooting Indoor Components.....	81 - 82
Troubleshooting Outdoor Components.....	83 - 92
Fault Codes & Status Displays.....	93 - 127
Troubleshooting Flow Charts.....	128 - 139
Fault Codes, Diagnostics & Status Displays.....	140 - 160
Disassembly of 115 volt Indoor Units.....	161 - 163
Disassembly of 9,000 & 12,000 btuh 120 volt Outdoor Systems.....	164 - 167
Disassembly of 9,000 btuh 240 volt Indoor Systems.....	168 - 170
..	
Disassembly of 9,000 btuh 240 volt Outdoor Systems.....	171 - 174
Disassembly of 12,000 btuh 240 volt Outdoor Systems.....	175 - 178
Disassembly of 18,000 btuh 240 volt Outdoor Systems.....	179 - 183

Table of Contents

Disassembly of 24,000 btuh 240 volt Outdoor Systems.....	184 - 188
Disassembly of 240 volt Indoor Systems.....	189 - 197
Disassembly of 30,000 & 36,000 240 volt Indoor Systems.....	198 - 204
Appendix 1 - 3 Temperature Sensor Resistance Tables.....	205 - 210

Safety Precautions & Warnings



Warning

Installing, starting up, and servicing air conditioner can be hazardous due to system pressure, electrical components, and equipment location, etc. Only trained, qualified installers and service personnel are allowed to install, start-up, and service this equipment. Untrained personnel can perform basic maintenance functions such as cleaning coils. All other operations should be performed by trained service personnel. When handling the equipment, observe precautions in the manual and on tags, stickers, and labels attached to the equipment. Follow all safety codes. Wear safety glasses and work gloves. Keep quenching cloth and fire extinguisher nearby when brazing. Read the instructions thoroughly and follow all warnings or cautions in literature and attached to the unit. Consult local building codes and current editions of national as well as local electrical codes.

Recognize the following safety information:



Warning: Incorrect handling could result in personal injury or death.



Caution: Incorrect handling may result in minor injury, or damage to product or property.



Warning

All electrical work must be performed by a qualified, licensed electrician according to local and national codes as well as the instructions provided in the manual.

- Before installing, modifying, or servicing the system, the main electrical disconnect must be off. There may be more than one disconnect switch. Lock out and tag switch with a suitable warning label.
- Never supply power to the unit unless all wiring and tubing are completed, reconnected and checked.
- This system adopts highly dangerous electrical voltage. Incorrect connections or inadequate grounding can cause personal injury or death. Refer to your local and national codes for proper grounding.
- Have the unit properly grounded with all connections tight. Loose connections can cause overheating and a possible fire hazard.



Caution

- Never install the unit in a place where a combustible gas might leak, or it may lead to fire or explosion.
- Make a proper provision against noise when the unit is installed at a telecommunication center or hospital.
- Provide a GFIC circuit when the local or national electric code requires it.
- Never wash the unit with water.
- Handle unit transportation with care. Use two people when the weight exceeds the capacity for one person.
- Never touch the heat exchanger fins with bare hands, sharp edges could cause personal injury.
- Never touch the compressor or refrigerant tubing without proper hand protection.
- Do not operate the unit without the air filters in place.
- Should any emergency occur, stop the unit and disconnect the electrical supply.
- Properly insulate tubing running inside the room to prevent water damage from condensation.



Warning

All installation or repair work shall be performed by your dealer or a specialized subcontractor as there is the risk of fire, electric shock, explosion or injury



Warning

Pressurized Refrigerant

Personal injury could result in failure to follow this warning. Systems contain oil and refrigerant under high pressure, proper refrigerant handling techniques should be completed by a qualified technician.



Warning

Live Electrical Components

Personal injury, property damage, or death could result in failure to follow this warning. Follow all electrical precautions when servicing this system, it may be necessary to service or troubleshoot with live electrical circuits. All work should be completed by a qualified technician.

Model Number Identification

Product Catalog Number-Nomenclature

Example NEO24HP230V1AH

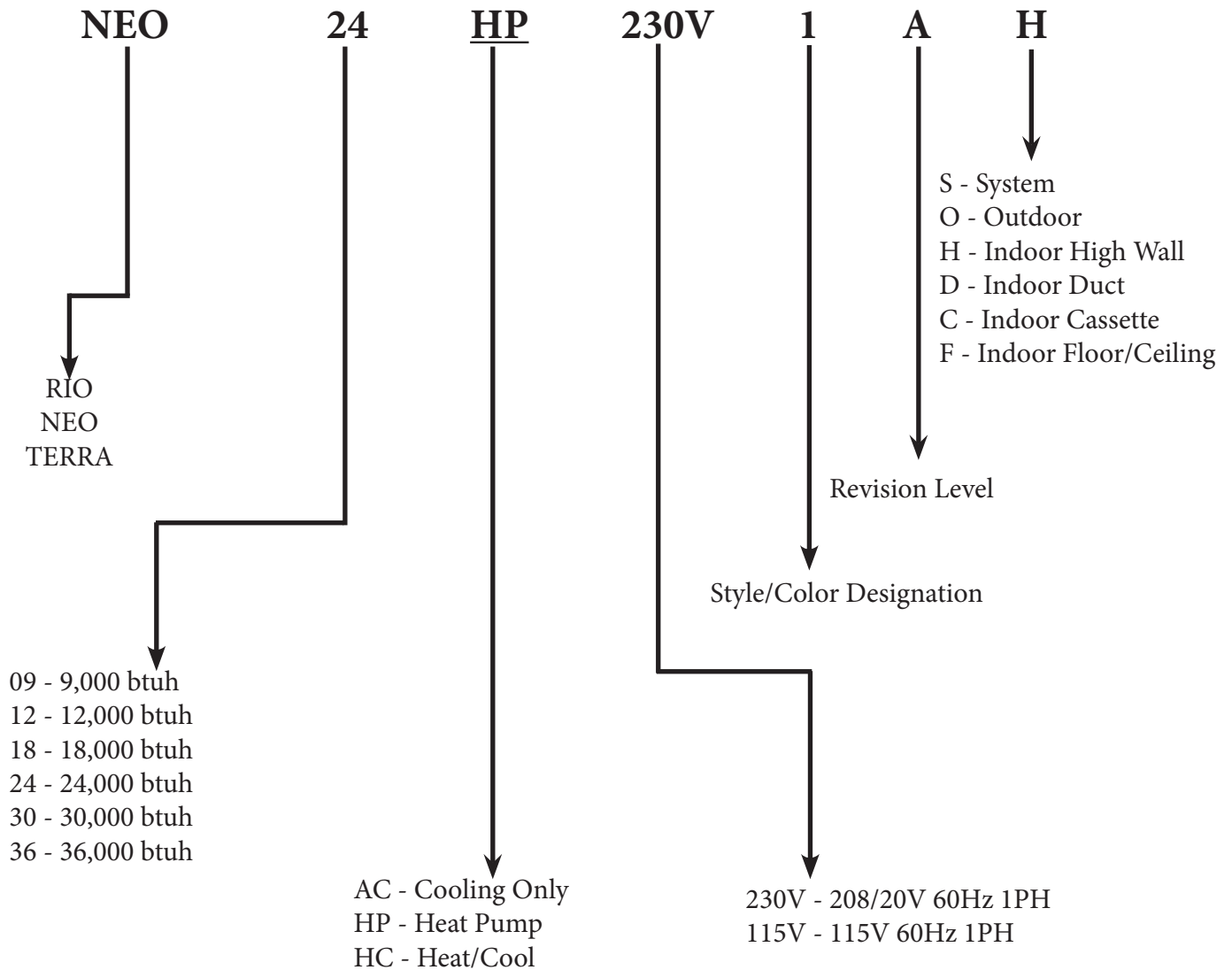

Physical & Electrical Data, cont.

Model		NEO09HP115V1AS	NEO12HP115V1AS
System Type		Heat Pump	
Power Supply		115V / 60Hz	115V / 60Hz
Rated Current Cooling	Amps	Standard 7.0 / High 16.8	Standard 11.0 / High 17.0
Rated Current Heating	Amps	Standard 7.5 / High 17.0	Standard 12.5 / High 18.2
System Performance			
Cooling Cap (Min/Max)	Btu/h	9,000 (4435-12000)	12,000 (4,500-14,000)
Heating Cap (Min/Max)	Btu/h	9,500 (3200-12500)	13,000 (3,250-14,500)
Operating Range - Cooling	deg F	55 - 115	55 - 115
Operating Range - Heating	deg F	5 - 75	5 - 75
System Specifications			
Compressor Type		DC Inverter-Driven Twin Rotary	
Sound Level (Indoor/Outdoor)	db	<=44 / <=63	<=46 / <=65
Net/Gross Weight Indoor	lb	24 / 31	24 / 31
Net/Gross Weight Outdoor	lb	79 / 90	88 / 97
ID & OD Coil Type		Acrylic Resin/Anti-Corrosion	
Refrigerant/Charge	oz	R410a / 41.2	R410a / 45.9
Line Set Size Liq. - Suction		1/4" - 3/8"	1/4" - 3/8"
Pre-Charged Lineset Ft.	Feet	25	25
Additional Refrigerant charge/additional feet	oz	0.22	0.22
Max. Total Piping Length	Feet	50	50
Max. Elevation	Feet	33	33
MCA	Amps	20	20
MOCP/Breaker Size	Amps	30	30
Wire Size to Outdoor Unit, # of Wires per Local Code	awg	10	10
Wire Size and # of Conductors from Indoor to Outdoor unit		14awg/4c	

Note: The manufacturer reserves the right to modify the design and/or change the specifications without notice. Please refer to specific installation manual for current information.

Physical & Electrical Data, cont.

Model		NEO09HP230V1AS	NEO12HP230V1AS
System Type		Heat Pump	
Power Supply		208 / 230v / 60Hz	208 / 230V / 60Hz
Rated Current Cooling	Amps	2.8	4.5
Rated Current Heating	Amps	3.0	5.2
System Performance			
Cooling Cap (Min/Max)	Btu/h	9,000 (3,500-9,600))	12,000 (3,100-13,500)
Heating Cap (Min/Max)	Btu/h	9,800 (2,200-11,000)	13,000 (2,400-14,000)
Operating Range - Cooling	deg F	5 - 109	5 - 109
Operating Range - Heating	deg F	5 - 75	5 - 75
System Specifications			
Compressor Type		DC Inverter-Driven Twin Rotary	
Sound Level	db	50	52
Net/Gross Weight Indoor	lb	22 / 29	22 / 29
Net/Gross Weight Outdoor	lb	79 / 90	88 / 97
ID & OD Coil Type		Acrylic Resin/Anti-Corrosion	
Refrigerant/Charge	oz	R410a / 45.9	R410a / 45.9
Line Set Size Liq. - Suction		1/4" - 3/8"	1/4" - 3/8"
Pre-Charged Lineset Ft.	Feet	25	25
Additional Refrigerant charge/additional feet	oz	0.22	0.22
Max. Total Piping Length	Feet	50	66
Max. Elevation	Feet	33	33
MCA	Amps	10	10
MOCP/Breaker Size	Amps	15	15
Wire Size to Outdoor Unit, # of Wires per Local Code	awg	14	14
Wire Size and # of Conductors from Indoor to Outdoor unit		14awg/4c	

Note: The manufacturer reserves the right to modify the design and/or change the specifications without notice. Please refer to specific installation manual for current information.

Physical & Electrical Data, cont.

Model		NEO18HP230V1AS	NEO24HP230V1AS
System Type		Heat Pump	
Power Supply		208-230v / 60Hz	208-230V / 60Hz
Rated Current Cooling	Amps	6.7	7.9
Rated Current Heating	Amps	7.3	9.3
System Performance			
Cooling Cap (Min/Max)	Btu/h	18,000 (5,970-22,350)	21,400 (9,600-25,000)
Heating Cap (Min/Max)	Btu/h	19,800 (4,100-22,000)	23,000 (4,300-26,000)
Operating Range - Cooling	deg F	25 - 115	25 - 115
Operating Range - Heating	deg F	5 - 65	5 - 65
System Specifications			
Compressor Type		DC Inverter-driven Twin Rotary	
Sound Level	db	56	58
Net/Gross Weight Indoor	lb	29 / 38	35 / 46
Net/Gross Weight Outdoor	lb	99 / 110	132 / 146
ID & OD Coil Type		Acrylic Resin/Anti-Corrosion	
Refrigerant/Charge	oz	R410a / 49.4	R410a / 56.4
Line Set Size Liq. - Suction		1/4" - 1/2"	1/4" - 5/8"
Pre-Charged Lineset Ft.	Feet	25	25
Additional Refrigerant charge/additional feet	oz	0.22	0.5
Max. Total Piping Length	Feet	82	82
Max. Elevation	Feet	33	33
MCA	Amps	13	16
MOCP/Breaker Size	Amps	20	25
Wire Size to Outdoor Unit, # of Wires per Local Code	awg	12	10
Wire Size and # of Conductors from Indoor to Outdoor unit		14awg/4c	

Note: The manufacturer reserves the right to modify the design and/or change the specifications without notice. Please refer to specific installation manual for current information.

Physical & Electrical Data, cont.

Model		NEO30HP230V1AS	NEO36HP230V1AS
System Type		Heat Pump	
Power Supply		208-230v / 60Hz	208-230V / 60Hz
Rated Current Cooling	Amps	12.1	15.9
Rated Current Heating	Amps	12.5	15.5
System Performance			
Cooling Cap (Min/Max)	Btu/h	28,000 (9,500-30,000))	33,600 (7,400-36,000)
Heating Cap (Min/Max)	Btu/h	28,400 (10,000-33,000)	34,600 (15,000-36,000)
Operating Range - Cooling	deg F	25 - 115	25 - 115
Operating Range - Heating	deg F	5 - 65	5 - 65
System Specifications			
Compressor Type		DC Inverter-driven Twin Rotary	
Sound Level	db	50	52
Net/Gross Weight Indoor	lb	22 / 29	22 / 29
Net/Gross Weight Outdoor	lb	75 / 90	88 / 97
ID & OD Coil Type		Acrylic Resin/Anti-Corrosion	
Refrigerant/Charge	oz	R410a / 84.7	R410a / 91.7
Line Set Size Liq. - Suction		1/4" - 5/8"	1/4" - 5/8"
Pre-Charged Lineset Ft.	Feet	25	25
Additional Refrigerant charge/additional feet	oz	0.5	0.5
Max. Total Piping Length	Feet	100	100
Max. Elevation	Feet	33	33
MCA	Amps	20	24
MOCP/Breaker Size	Amps	30	35
Wire Size to Outdoor Unit, # of Wires per Local Code	awg	10	8
Wire Size and # of Conductors from Indoor to Outdoor unit		14awg/4c	

Note: The manufacturer reserves the right to modify the design and/or change the specifications without notice. Please refer to specific installation manual for current information.

Product Introduction

System Overview

The Neo Ductless split heat pumps are single zone units available in size from 9000 btuh to 36,000 btuh providing heating and cooling. All comfort settings are controlled by a remote control. The Neo unit has many features to enhance comfort and efficiency. The operation of these features will be explained later in this service manual.

Superior inverter technology is used to control capacity while maintaining maximum efficiency. The Neo systems are equipped with G10 inverter technology providing precise control over the compressor frequency based on operating pressures and temperatures. Should an abnormal condition occur, the software will adjust the compressor frequency or shut down the system indicating the appropriate fault.

The indoor unit contains a digital display, which will indicate the current fault. The evaporator, swing motors, fan motors and circuit board are also components of the indoor unit. The indoor units have a bypass switch to bypass the remote control if lost or batteries fail. This will be explained later in this service manual.

The systems require R410A and are pre-charged for 25' of lineset. Please refer to your installation manual for additional charge for linesets longer than 25'.

The maximum allowable line lift and distances vary by model, please refer to the charts in the manual for proper lineset applications.

The systems use a PVE oil and should require no additional oil. All Neo units utilize an Oil Return Mode which will return oil to the compressor should the need arise.

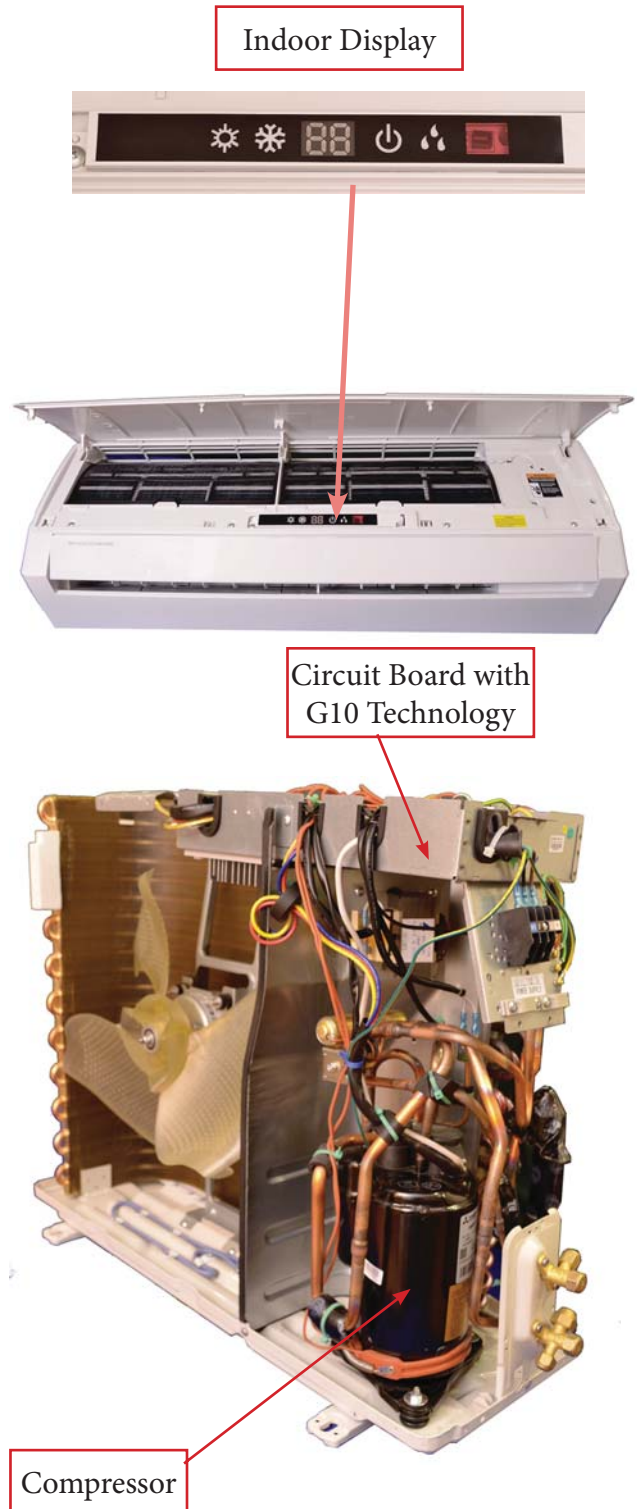

Product Introduction

Refrigeration Components

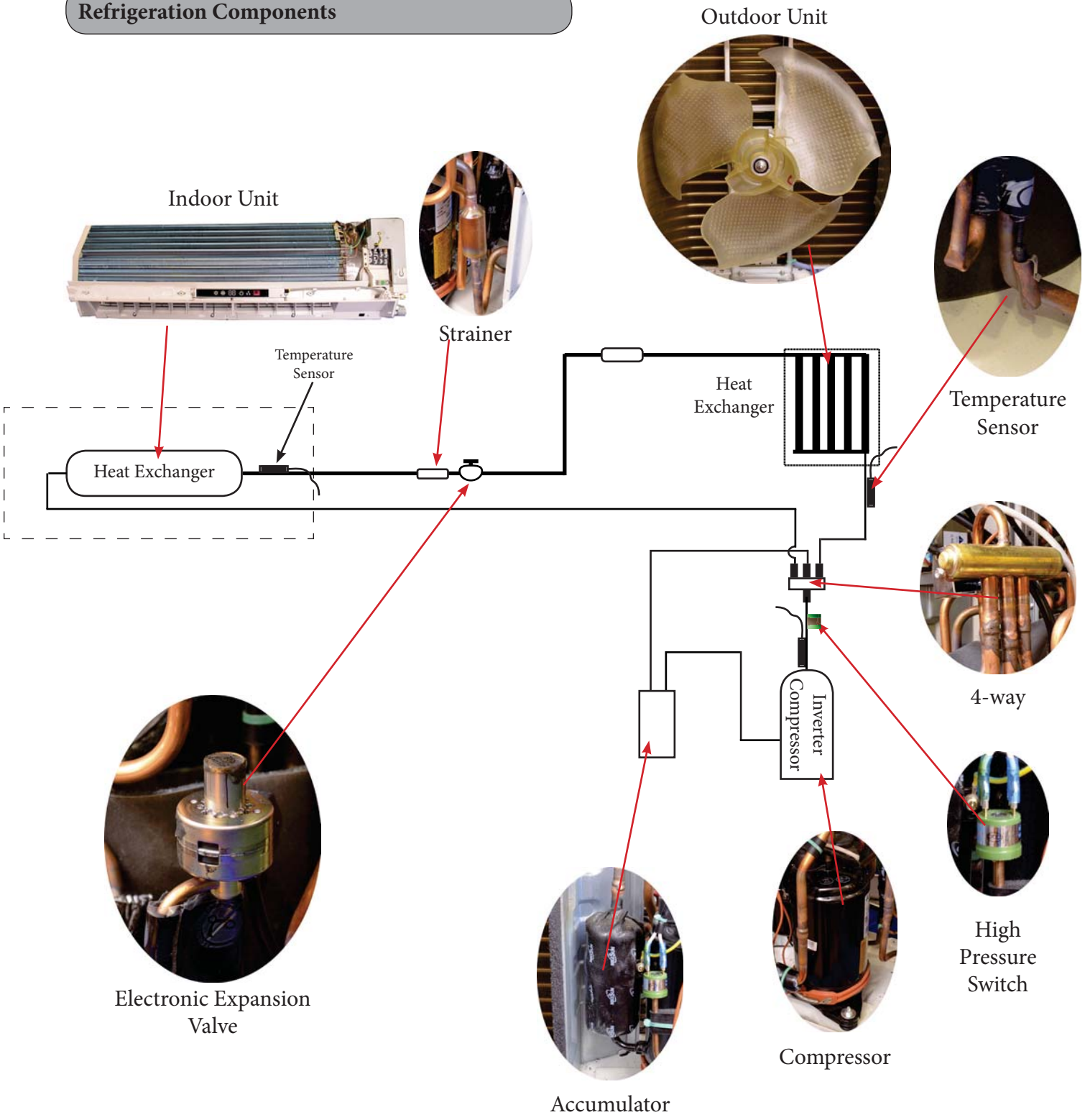

Note:
Component locations may vary depending on models.

Product Introduction

Cooling Mode

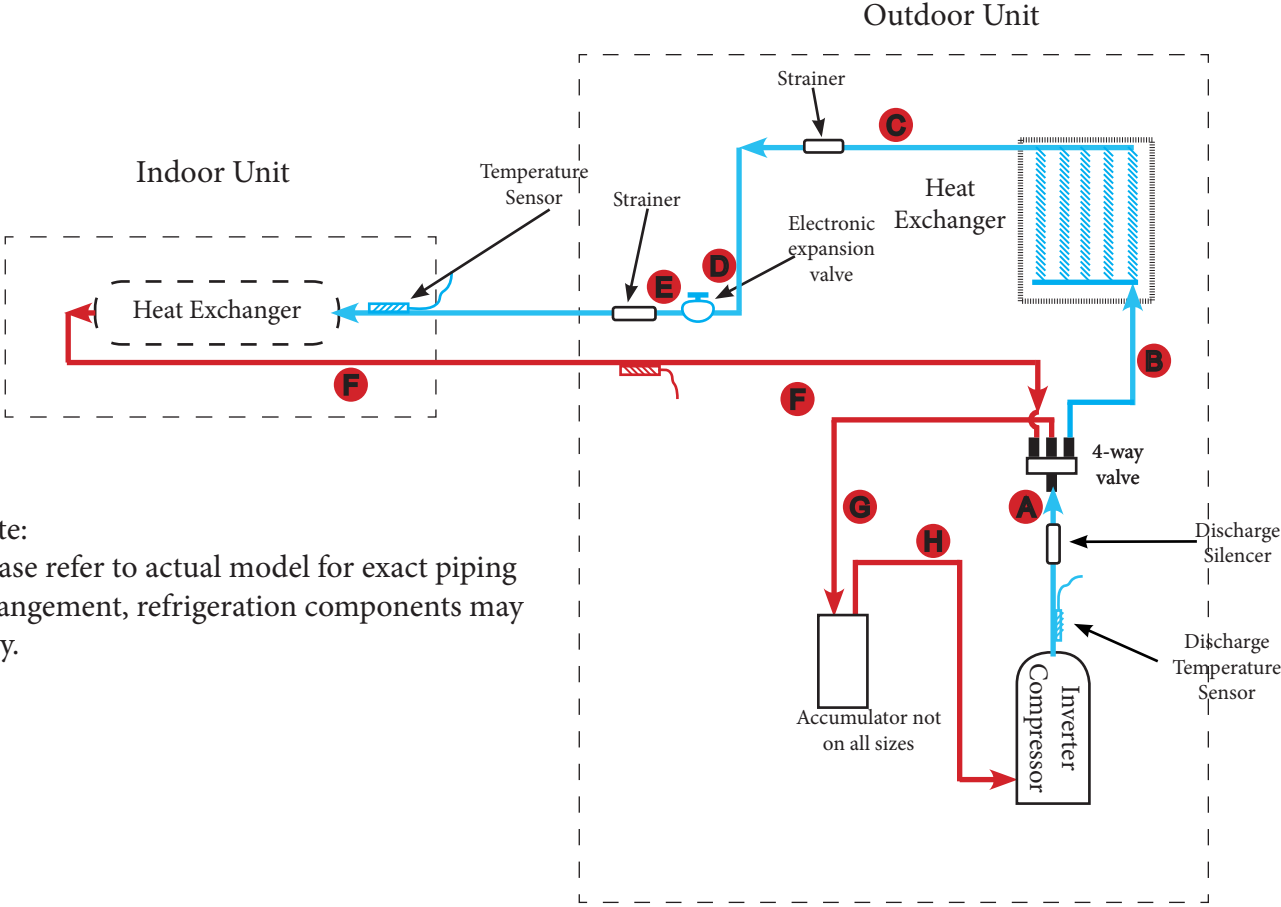

Note:
Please refer to actual model for exact piping arrangement, refrigeration components may vary.

Note: The manufacturer reserves the right to modify the design and/or change the specifications without notice. Please refer to specific installation manual for current information.

Product Introduction

Cooling Mode

- A. Hot gas is discharged from the compressor. The temperature of the gas is monitored by the Discharge Temperature sensor and sent to the outdoor control panel.
- B. The hot gas is directed through the 4-way valve, then enters the outdoor coil. The hot gas will be slightly subcooled, however there are no pressure ports to take measurements.
- C. The subcooled liquid will enter the filter to remove contaminants.
- D. The subcooled liquid will enter the Electronic Expansion Valve (EEV) and will regulate to about a 10 degree superheat level. The EEV will adjust its flow based upon the temperature sensor readings. The adjustment process and compressor speed are controlled by the outdoor circuit board.
- E. The refrigerant leaving the EEV will be in a low pressure/temperature saturated state. This cold saturated refrigerant will move through the coil absorbing heat. This liquid will flash to a vapor and will be superheated to about 10 degrees F. Since this tubing is cold, it must be insulated.
- F. The superheated vapor will be returned to the outdoor unit's 4-way valve.
- G. The refrigerant will flow to the accumulator (not all models will have an accumulator) where liquid and vapor are separated.
- H. The refrigerant will flow to the compressor and complete another refrigeration cycle.

The control board will monitor the temperature and pressures and adjust the frequency of the compressor and flow rate of the EEV as needed. There are no pressure charts to evaluate temperature or pressures.

Product Introduction

Heating Mode

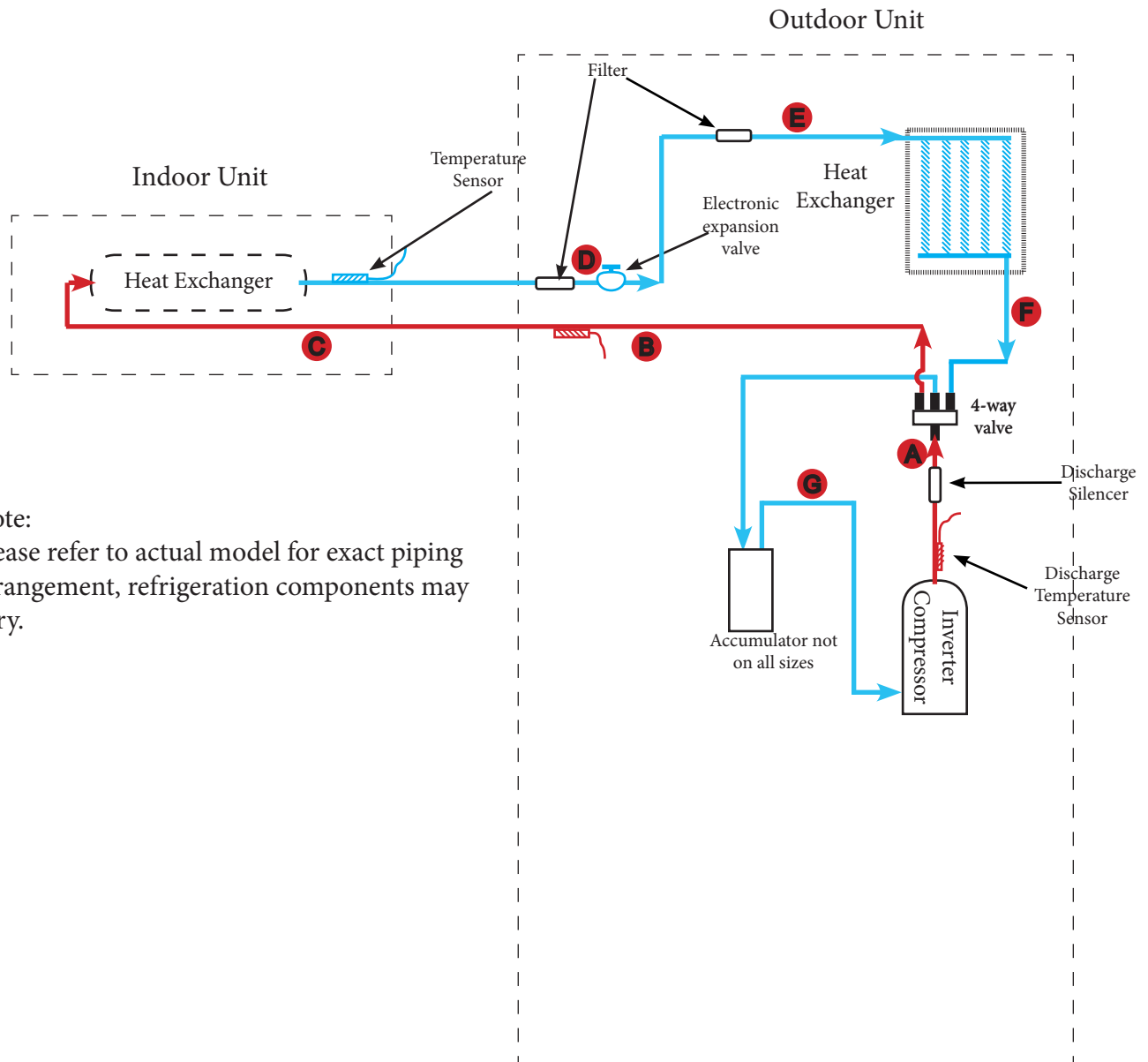

Note:
Please refer to actual model for exact piping arrangement, refrigeration components may vary.

Note: The manufacturer reserves the right to modify the design and/or change the specifications without notice. Please refer to specific installation manual for current information.

Product Introduction

Heating Mode

- A. Hot gas is discharged from the compressor. The temperature of the gas is monitored by the Discharge Temperature sensor and sent to the outdoor control panel.
- B. The hot gas is directed through the 4-way valve to the appropriate indoor coil making the line a hot gas line.
- C. The hot gas will enter the indoor coil and condense to a saturated mix as it travel through the coil and will be slightly subcooled.
- D. The refrigerant returns to the outdoor unit through the filter, then through the EEV reducing the refrigerant to a low pressure liquid and will maintain 10 degrees F of superheat.
- E. The cold refrigerant will travel through the outdoor coil (evaporator) and will pickup heat from the outdoor air. This will cause the cold saturated refrigerant to flash to a saturated mixture which will be superheated to 10 degrees F.
- F. The superheated vapor will travel through the 4-way valve to the accumulator which will prevent liquid floodback.
- G. The superheated gas will enter the compressor for another refrigeration cycle.

The control board will monitor the temperature and pressures and adjust the frequency of the compressor and flow rate of the EEV as needed. There are no pressure charts to evaluate temperature or pressures.

Product Introduction

Indoor Unit Components

Neo 12,000 btuh model
Other Neo models may vary slightly.

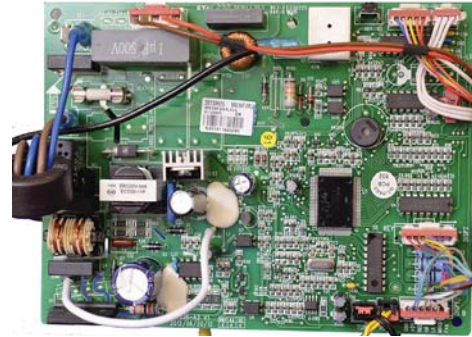
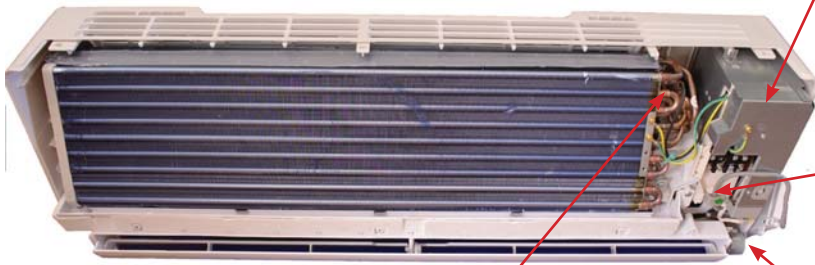

Indoor Circuit Board

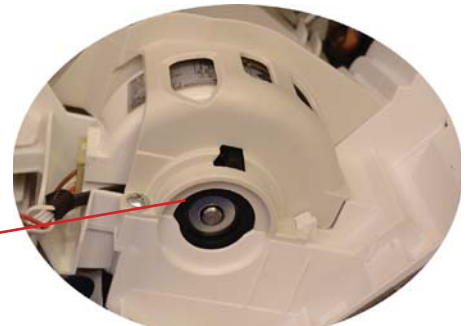

Fan Motor

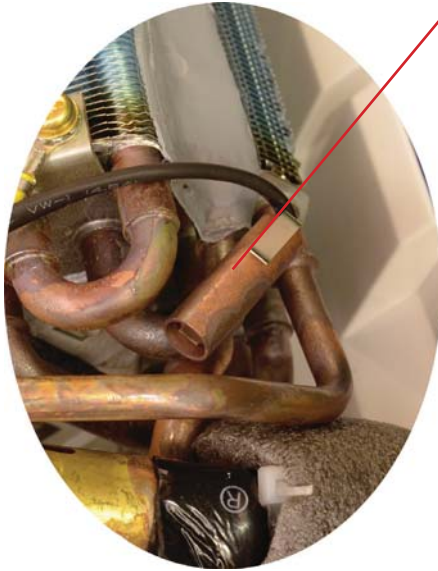

Indoor Tube Thermistor

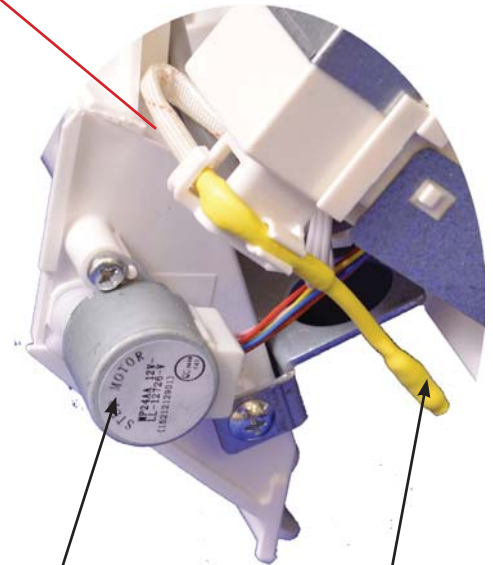

Swing Motor

Ambient Temperature Sensor

Product Introduction

Outdoor Unit Components

Neo 12,000 btuh Outdoor Unit
Other Neo models may vary slightly.



Outdoor Fan



API Board

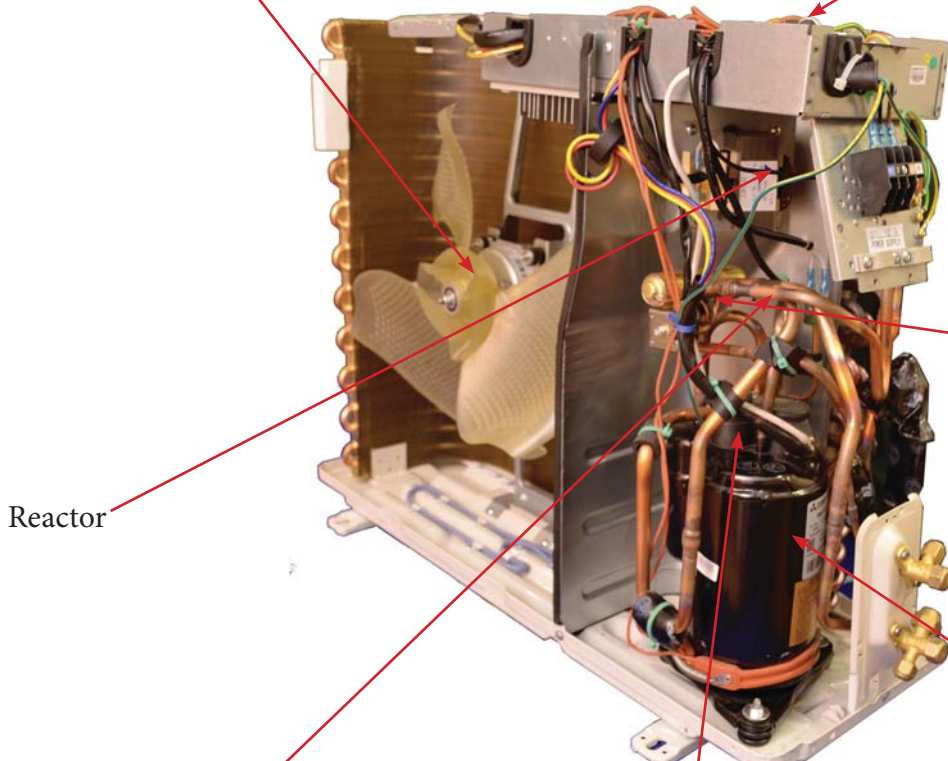

Reactor



4-Way Valve



Exhaust Temp
Sensor



High Pressure Switch



Compressor

Note:
Component locations may vary depending on models.

Product Introduction

Outdoor Unit Components

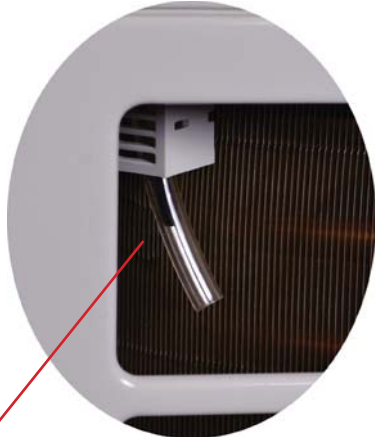

Outdoor Air Sensor

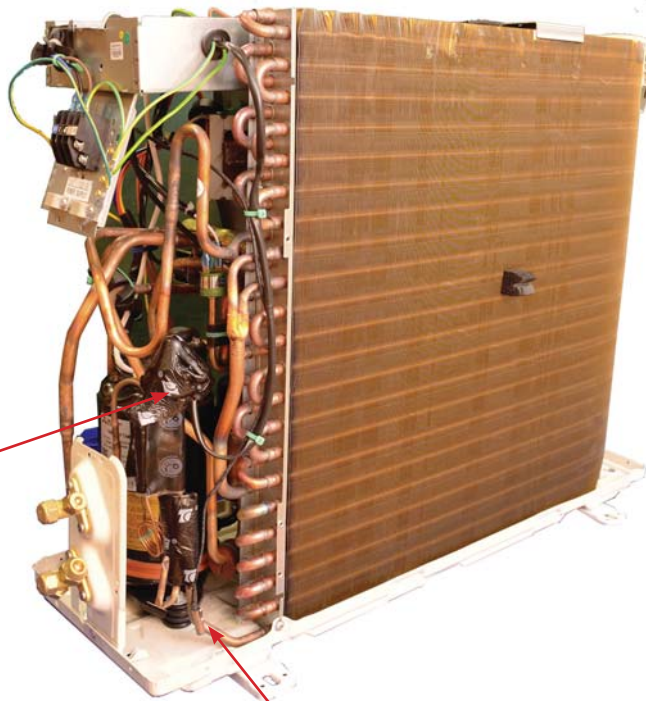

Electronic Expansion Valve



Outdoor tube Sensor

Product Introduction

Basic Functions - 9K & 12K 115 volt

6.2 Brief Description of Modes and Functions

1. Temperature Parameters

- ◆ Indoor preset temperature (T_{preset})
- ◆ Indoor ambient temperature ($T_{\text{amb.}}$)

2. Basic Functions

Once the unit energized, the compressor shall never be restarted except 3mins interval at least. For the first energization, if the unit is at off status before power failure, the compressor can be restarted without 3-min delay. But if the unit is at ON status before power failure, the compressor shall be restarted with 3mins delay. Once the compressor is started up, the compressor won't stop running within 6mins with the change of room temperature.

(1) Cooling Mode

1. Under this mode, fan and swing function will be operating under setting mode, and temperature setting range is 61~86°F.

2. When outdoor unit is with malfunction or stop operation because of malfunction, indoor unit will keep its original operation status and display the malfunction.

3. When $0^{\circ}\text{F} \leq (\text{setting temperature} - \text{ambient temperature}) < 3.6^{\circ}\text{F}$, if indoor fan speed is at high level, it will turn to medium level (when compressor is operating); if indoor fan speed is at ultra high level, it will not turn to other fan speed; when $(\text{ambient temperature} - \text{setting temperature}) \geq 1.8^{\circ}\text{F}$, the fan speed will resume to setting value.

(2) Dry Mode

1. Under this mode, fan will operate as low fan speed and swing at setting status, temperature setting range is 61~86°F.

2. When outdoor unit is with malfunction or stop operation because of malfunction, indoor unit will keep its original operation status and display the malfunction.

(3) Heating Mode

1. Heating Conditions and Process

When the unit is powered on and is under heating mode, IDU will turn to anti cold wind function; when the unit is powered off and the indoor fan had ever turned on, the unit will turn to blowing residual heat.

2. When the compressor is running (doesn't include entering each malfunction and protection):

a. When $T_{\text{outdoor ambient}} \geq 68^{\circ}\text{F}$, if the indoor fan speed is low or medium, the fan speed will switch to high speed; if the fan speed is high or turbo, the fan speed will not change.

b. When $T_{\text{outdoor ambient}} \leq 64^{\circ}\text{F}$, the fan speed will turn back to set fan speed;

c. When $64^{\circ}\text{F} < T_{\text{outdoor ambient}} < 68^{\circ}\text{F}$, the unit will run in present fan speed (set fan speed or high fan speed); but if the unit quits anti cold wind for the first time in heating mode, the unit will run in set fan speed.

3. Defrosting

When there's too much frost on outdoor condenser, the complete unit will enter into defrosting automatically to assure the best heating effect. During defrosting process, the heating indicator is on for 10s and off for 0.5s.

4. Blow Residual Heat

When heating temperature reaches to the temperature point of stop operation, compressor and outdoor fan will stop operation. The horizontal louver rotates to the defaulted position in cooling mode. Indoor fan will stop operation after operating at set fan speed for 60s. When the unit operates in heating or auto heating mode, compressor is started up and the unit will stop operation after indoor fan starts operation. Compressor and outdoor fan stop operation. The horizontal louver will rotate to the position of breeze (defaulted position in cooling). The unit will stop operation after indoor fan operates at low fan speed for 10s. If the indoor fan stops due to blocking of PG motor, the louvers stop at the position when the unit stops. (If the unit stops for other malfunction, the vertical louvers turn to cooling position 2) Indoor fan runs in set fan speed for 60s and then stops.

Product Introduction

Basic Functions - 9K & 12K 115 volt

5. Cold Air Prevention

After the compressor starts, the indoor unit and louvers run in the mode below:

1. When $T_{\text{indoor ambient}} < 75^{\circ}\text{F}$: if $T_{\text{tube}} \leq 104^{\circ}\text{F}$, the indoor fan doesn't run and then the indoor fan runs in low fan speed after 2min. In 2min, if $T_{\text{tube}} > 104^{\circ}\text{F}$, the indoor fan will also run in low fan speed; after running in low speed for 1min, the indoor fan will turn to run in set fan speed. In 1 minute of low fan speed or in 2 minute that the indoor fan doesn't run, if $T_{\text{tube}} > 108^{\circ}\text{F}$, the indoor fan will turn to run in set fan speed.

2. When $T_{\text{indoor ambient}} \geq 75^{\circ}\text{F}$: if $T_{\text{tube}} \leq 108^{\circ}\text{F}$, the indoor fan runs in low fan speed and then the indoor fan runs in set fan speed after 1min. In 1min of running in low fan speed, if $T_{\text{tube}} > 108^{\circ}\text{F}$, the indoor fan will turn to run in set fan speed.

Note: $T_{\text{indoor ambient}}$ in 1 and 2 means at the beginning of heating mode, the indoor ambient temperature before starting up the compressor, or after quitting defrosting, the indoor ambient temperature before clearing the defrosting symbol.

(4) Fan Mode

In fan mode, indoor fan operates at set fan speed, while compressor and outdoor fan all stop operation.

In fan mode, the temperature setting range is $61 \sim 86^{\circ}\text{F}$. Display is displaying operation icon and set temperature.

(5) Auto Mode

In auto mode, the system will select the operation mode (cooling, heating or fan mode) according to the change of ambient temperature automatically. The display displays operation icon, actual operation mode and set temperature. 30s will be delayed for protection during mode switchover. Protection function is the same as that in other modes.

The selection method for auto operation mode in details is as below:

a. When $T_{\text{amb.}} \geq 79^{\circ}\text{F}$, the unit operates in cooling mode. The defaulted set temperature is 77°F ;

b. When $T_{\text{amb.}} \leq 72^{\circ}\text{F}$, the unit operates in heating mode. The defaulted set temperature is 68°F (if it's the cooling only unit that operates in fan mode, the defaulted set temperature is 77°F);

c. When $73^{\circ}\text{F} \leq T_{\text{amb.}} \leq 77^{\circ}\text{F}$, if the unit is turned on for the first time, it will operate in auto fan mode; if the unit switched to auto mode from other mode, it will keep previous operation mode; if the unit is switched to auto mode from dry mode, it will operate in fan mode.

d. When the unit operates in auto mode, frequency of compressor during cooling and heating is same as that in cooling mode and heating mode respectively.

Protection function:

a. It's the same as that in cooling mode when it operates in cooling;

b. It's the same as that in heating mode when it operates in heating;

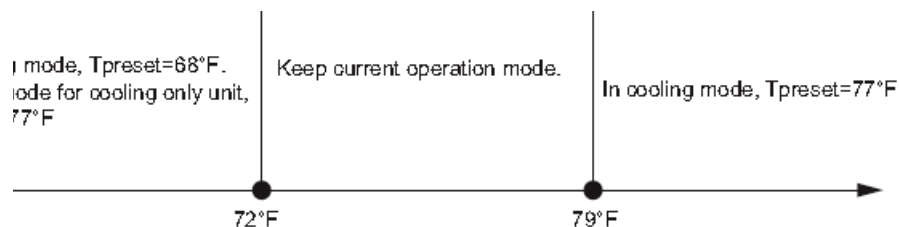

3. Other Control

(1) Timer Function

General timer and clock timer functions are compatible by equipping remote controller with different functions.

1. General Timer

Timer ON can be set at unit OFF. If selected ON time is reached, the unit will start to operate according to previous setting status. Time setting range is 0.5-24hr in 30-minute increments. Timer OFF can be set at unit ON. If selected OFF time is reached, the unit will stop operation. Time setting range is 0.5-24hr in 30-minute increments.

Product Introduction

Basic Functions - 9K & 12K 115 volt

2. Clock Timer (it's optional for the remote controller with clock timer)

Timer ON

If timer ON is set during operation of the unit, the unit will continue to operate. If timer ON is set at unit OFF, upon ON time reaches the unit will start to operate according to previous setting status.

Timer OFF

If timer OFF is set at unit OFF, the system will keep standby status. If timer OFF is set at unit ON, upon OFF time reaches the unit will stop operation.

Timer Change

Although timer has been set, the unit still can be turned on/off by pressing ON/OFF button of the remote controller. You can also set the timer once again, and then the unit will operate according to the last setting.

If timer ON and timer OFF are set at the same time during operation of the unit, the unit will keep operating at current status till OFF time reaches.

If timer ON and timer OFF are set at the same time at unit OFF, the unit will keep off status till ON time reaches.

Each day in future, the system will operate according to preset mode till OFF time reaches and stop operation till ON time reaches. If ON time and OFF time are the same, OFF command takes the priority.

time and OFF time are the same, OFF command takes the priority.

(2) Auto Button

If this button is pressed, the unit will operate in AUTO mode and indoor fan will operate at auto speed; meanwhile, the swing motor operates.

Press this button again to turn off the unit.

(3) Buzzer

Upon energization or availably operating the unit or remote controller, the buzzer will give out a beep.

(4) Sleep Function

1. Cooling mode:

1.1 When initial set temperature range is 61~73°F, if turning on sleep function, temperature will increase 1.8°F for every hour. After 5.4°F has been increased, the temperature will not change. 7 hours later, temperature will decrease 1.8°F. After that, the unit will keep operating at that temperature.

1.2 When initial set temperature range is 75~81°F, if turning on sleep function, temperature will increase 1.8°F for every hour. After 3.6°F has been increased, the temperature will not change. 7 hours later, temperature will decrease 1.8°F. After that, the unit will keep operating at that temperature.

1.3 When initial set temperature range is 82~84°F, if turning on sleep function, temperature will increase 1.8°F for every hour. After 1.8°F has been increased, the temperature will not change. 7 hours later, temperature will decrease 1.8°F. After that, the unit will keep operating at that temperature. 1.4 When initial set temperature is 86°F, the unit will operate at that temperature. 7 hours later, temperature will decrease 1.8°F. After that, the unit will keep operating at that temperature.

2. Heating mode:

2.1 When initial set temperature is 61°F, the unit will operate at that temperature;

2.2 When initial set temperature range is 63~68°F, if turning on sleep function, temperature will decrease 1.8°F for every hour. After 1.8°F has been decreased, the temperature will not change.

2.3 When initial set temperature range is 70~81°F, if turning on sleep function, temperature will decrease 1.8°F for every hour. After 3.6°F has been decreased, the temperature will not change. 2.4 When initial set temperature range is 82~86°F, if turning on sleep function, temperature will decrease 1.8°F for every hour. After 5.4°F has been decreased, the temperature will not change.

(5) Turbo Function

This function can be set in cooling or heating mode to quickly cool or heat the room.

Product Introduction

Basic Functions - 9K & 12K 115 volt

(6) X-fan Function

1. X-fan function can be set in cooling or drying mode (X-fan function is unavailable in auto, heating or fan mode). When X-fan is ON, after pressing ON/OFF button to turn off the unit, indoor unit will run in low fan speed for 2min(in 2min, the horizontal louver is in the minimum angel of swinging, other loads are off). When X-fan is OFF, press ON/OFF button to turn off the complete unit.

2. During X-fan operation, after pressing X-fan button, indoor fan stops operates immediately. Horizontal louver will close and cold plasma and electrostatic dedusting is OFF as well.

(7) Control of Indoor Fan

The fan speed of indoor fan can be set in turbo, high, medium, low by remote controller.

It can also set at auto fan speed. When indoor fan operates in auto fan speed mode, the indoor fan will operate at high speed, medium speed, low speed or turbo according to the change of ambient temperature.

3. In auto heating mode or normal heating mode, the auto fan speed operates according to below mode:

When $T_{amb} < T_{preset} - 1.8^{\circ}F$, indoor fan operates at high speed;

When $T_{preset} - 1.8^{\circ}F < T_{amb} < T_{preset} + 1.8^{\circ}F$, indoor fan operates at medium speed;

When $T_{amb} > T_{preset} + 1.8^{\circ}F$, indoor fan operates at low speed. Control drawing of auto fan in heating mode:

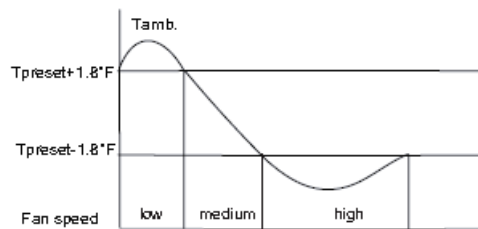

2. Fan mode, cooling mode: In auto cooling mode or normal cooling mode, auto fan speed operates according to below mode:

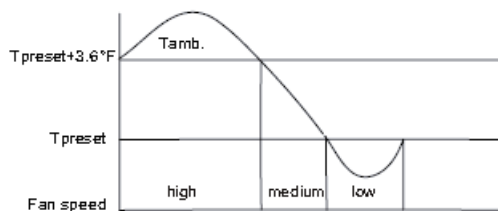

3. Auto fan speed is not available in drying mode

Note: high speed, medium speed and low speed is to “notch 5”, “notch 3” and “notch 1” respectively.

As for the switchover among high speed, medium speed and low speed, the unit should operate at every speed for 3 minutes and 3s at least.

Product Introduction

Basic Functions - 9K & 12K 115 volt

(8) Up and Down Swing Function

After turning on the unit, the louver will operate in the below angle. (if the remote controller is pressed continuously within 2 seconds, the last signal will be executed, the previous signals will be invalid)

After energizing, the up and down swing motor will firstly rotate the louver to position 0 anticlockwise (close in 138°) and close the air outlet. After turning on the unit, if swing function has been set, the louver will rotate to position D clockwise in heating mode and auto heating mode; the louver will rotate to horizontal position L1 clockwise in other modes. The indoor fan and compressor will be energized after the louver opens to position L1. If set the swing function while turning on the unit, the louver will swing between L1 and D. The louver will close to position L when turning off the unit.

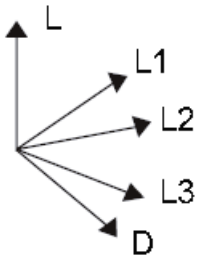

(9) Display

1. Upon energization within 2s, the unit will display all icons. Under standby state, running indicating mark is displayed. If the unit is started by remote controller, running indicating mark gives off light; meanwhile, the mark of current running mode will be displayed. If the light button is turned off, no mark will be displayed.
2. In defrosting, the heating indicator is on for 10s and off for 0.5s. In X-fan mode, the cooling indicator is on for 0.5s and off for 10s.
3. In auto mode, the nixie tube displays 25 in cooling and fan, and displays 20 in heating.
4. The nixie tube displays set temperature.
5. When there is a malfunction or protection, if timer off is set, this function will be executed.

(10) Memory Function

Memorized items: mode, up & down swing, light, set temperature and set fan speed.

When power is recovered after power failure, the unit will automatically start operation according to memorized status. After power recovery, the unit without timer setting before power failure will operate according to the last setting; the unit with general timer setting which has not been fulfilled before power failure will memorize the timer setting and re-calculate the time after power recovery. If there is timer function in the last remote controller command but setting time has reached, the system will act as timer on/off setting before power failure. After power failure, the system memorizes the operation states before power failure without timer action. Clock timer can not be memorized.

(10) Memory Function

Memorized items: mode, up & down swing, light, set temperature and set fan speed.

When power is recovered after power failure, the unit will automatically start operation according to memorized status. After power recovery, the unit without timer setting before power failure will operate according to the last setting; the unit with general timer setting which has not been fulfilled before power failure will memorize the timer setting and re-calculate the time after power recovery. If there is timer function in the last remote controller command but setting time has reached, the system will act as timer on/off setting before power failure. After power failure, the system memorizes the operation states before power failure without timer action. Clock timer can not be memorized.

Product Introduction

Basic Functions - 9K & 12K 115 volt

(11) I FEEL Function(reserved)

When I FEEL command is received and controller has received the ambient temperature sent by remote controller, the controller will operate at the temperature sent by remote controller (For cold air prevention, the unit operates according to the ambient temperature sensed by the air conditioner). If it only received I FEEL command and hasn't received the valid ambient temperature, air conditioner will operate according to the ambient temperature sensed by itself. Remote controller will send the ambient temperature to controller every 10min. If controller hasn't received the ambient temperature sent by remote controller for 11min, air conditioner will operate according to the ambient temperature sensed by itself. If I FEEL hasn't been set, ambient temperature will adopt the temperature sensed by air conditioner. Controller displays I FEEL ambient temperature 34°F~138°F.

(12) Health, Cold Plasma Function(reserved)

At ON status, press health button (if there isn't health button on remote controller, health function is ON in default) on remote controller can set health or cold plasma function. Health or cold plasma function can operate when it set ON and indoor fan operates.

(13) Fahrenheit Display Function

Nixie tube displays current set temperature. If the remote control signal is Fahrenheit, the temperature will be display by Fahrenheit. Set temperature range is 61~86°F. Under auto mode, nixie tube displays 77°F in cooling and fan, and 68°F in heating. Cooling only controller only displays 77°F.

(14) Locked Protection to Indoor Fan

If the indoor fan motor keeps low rotation speed for a continuous period of time after startup, the unit will stop operation and display "H6".

(15) Compulsory Defrosting Function

When the outdoor environment is formidable, such as temperature is too low and humidity is too high, and there is too much frost in outdoor unit which affect the heating effect, users can select compulsory defrosting function to outdoor unit's heating effect. on method:

When the unit is turned on in heating mode by remote controller and the set temperature is 61°F, press "+,-,+,-,+,-" buttons for 5s successively, indoor unit will enter into compulsory defrosting setting and send the compulsory defrosting mode signal to outdoor unit and then outdoor unit will enter into compulsory defrosting mode.

Product Introduction

Left Intentionally Blank

Product Introduction

Basic Functions - 9K & 12K 230 volt

- ◆ Indoor preset temperature (T_{preset})
- ◆ Indoor ambient temperature (T_{amb})

2. Basic Functions

Once energized, in no case should the compressor be restarted within less than 3 minutes. In the situation that memory function is available, for the first energization, if the compressor is at stop before de-energization, the compressor will be started without a 3-minute lag; if the compressor is in operation before de-energization, the compressor will be started with a 3-minute lag; and once started, the compressor will not be stopped within 6 minutes regardless of changes in room temperature;

(1) Cooling Mode

1. Working conditions and process of cooling

When $T_{\text{amb}} \geq T_{\text{preset}}$, the unit will enter cooling operation, in which case the indoor fan, the outdoor fan and the compressor will work and the indoor fan will run at preset speed.

When $T_{\text{amb}} = T_{\text{preset}} - 3.6^\circ\text{F}$, the compressor will run in 15Hz for continuous 15 minutes; if $T_{\text{amb}} = T_{\text{preset}} - 3.6^\circ\text{F}$ is not changed after that, the compressor will stop to run;

When $T_{\text{amb}} \leq T_{\text{preset}} - 5.4^\circ\text{F}$, the compressor will stop to run, the outdoor fan motor will stop to run after 30 seconds and the indoor fan motor will run at set fan speed;

When $T_{\text{preset}} - 3.6^\circ\text{F} < T_{\text{amb}} < T_{\text{preset}}$, the unit will keep the previous running status.

Under this mode, the four-way valve will be de-energized and temperature can be set within a range from 61 to 86°F.

If the compressor is shut down for some reason, the indoor fan and the swing device will operate at original state.

2. Protection

- ◆ Antifreeze protection

Under cooling and dehumidifying mode, 6 minutes after the compressor is started:

If $T_{\text{evap}} \leq 35.6^\circ\text{F}$, the compressor will operate at reduced frequency.

If $T_{\text{evap}} \leq 30.2^\circ\text{F}$ is detected for durative 3 minutes, the compressor will stop, and after 30 seconds, the outdoor fan will stop; and under cooling mode, the indoor fan and the swing motor will remain at the original state.

If $T_{\text{evap}} \geq 50^\circ\text{F}$ and the compressor has remained at OFF for at least 3 minutes, the compressor will resume its original operation state.

- ◆ Total current up and frequency down protection

When total current $I_{\text{total}} \leq 6\text{A}$, increase frequency is allowed; when total current $I_{\text{total}} \geq 7\text{A}$, increasing frequency is prohibited; when total current $I_{\text{total}} \geq 8\text{A}$, the unit operates by decreasing frequency. When total current $I_{\text{total}} \geq 9\text{A}$, the compressor stops operation, and indoor fan will stop operation after 30s.

(2) Dehumidifying Mode

1. Working conditions and process of dehumidifying

If $T_{\text{amb}} > T_{\text{preset}}$, the unit will enter cooling and dehumidifying mode, in which case the compressor and the outdoor fan will operate

and the indoor fan will run at low speed.

If $T_{\text{preset}} - 3.6^\circ\text{F} \leq T_{\text{amb}} \leq T_{\text{preset}}$, the compressor remains at its original operation state.

If $T_{\text{amb}} < T_{\text{preset}} - 3.6^\circ\text{F}$, the compressor will stop, the outdoor fan will stop with a time lag of 30s, and the indoor fan will operate at

low speed.

2. Protection

Protection is the same as that under the cooling mode.

(3) Heating Mode

1. Working conditions and process of heating

1. If $T_{\text{preset}} - (T_{\text{indoor ambient}} - T_{\text{compensatory}}) \geq 1.8^\circ\text{F}$, the unit enters heating mode, in which case the compressor, the outdoor fan and the 4-way valve will operate simultaneously;

2. If $-3.6^\circ\text{F} < T_{\text{preset}} - (T_{\text{indoor ambient}} - T_{\text{compensatory}}) < 1.8^\circ\text{F}$, the unit will maintain its original operating status.

Product Introduction

Basic Functions - 9K & 12K 230 volt

3. If $T_{\text{preset}} - (T_{\text{indoor ambient}} - T_{\text{compensatory}}) \leq -3.6^{\circ}\text{F}$, the compressor will stop and the outdoor fan will stop with a time lag of 30s;
4. If turning off the unit when the unit is in heating mode or switching heating mode to another mode, the 4-way valve will be powered off after the compressor stops for 2min (the compressor has already started in heating mode).
5. If $T_{\text{outdoor ambient}} > 86^{\circ}\text{F}$, the compressor will stop and the outdoor fan will stop with a time lag of 30s
6. When the compressor has started, if switching cooling or dry mode to heating mode, the 4-way valve will be energized with a time lag of 2-3min.

Note: $T_{\text{compensatory}}$ is determined by indoor unit and outdoor unit. If the indoor unit controls $T_{\text{compensatory}}$, $T_{\text{compensatory}}$ is determined by the data sent by indoor unit to outdoor unit; if the indoor unit doesn't control $T_{\text{compensatory}}$, the outdoor unit will control $T_{\text{compensatory}}$ and the default data is 5.4°F . (there is instruction in the communication protocol to describe if the $T_{\text{compensatory}}$ is controlled by indoor unit)

2. Condition and process of defrost

(1) When $T_{\text{outdoor ambient}} \leq 41^{\circ}\text{F}$ and the compressor has run for 3h, if $T_{\text{outdoor tube}} < 0^{\circ}\text{F}$ is continuously detected for 1min, the unit will enter defrosting; [Note: the accumulated time is cleared if one of the below condition is met: $T_{\text{outdoor ambient}} > 41^{\circ}\text{F}$, the compressor starts up after switching to cooling or dry mode, when defrosting is finished; for other situations besides above conditions, the accumulated time will not be cleared (including the unit stops when reaching the temperature point, the unit stops for protection, switching to fan mode, etc.)]

(2) When duration of successive heating operation is more than 45 minutes, or accumulated heating time more than 90 minutes, and one of the following conditions is reached, the unit will enter the defrost mode after 3 minutes:

- a. $T_{\text{outdoor ambient}} > 41^{\circ}\text{F}$, $T_{\text{outdoor tube}} \leq 28.4^{\circ}\text{F}$;
- b. $28.4^{\circ}\text{F} \leq T_{\text{outdoor ambient}} < 41^{\circ}\text{F}$, $T_{\text{outdoor tube}} \leq 21.2^{\circ}\text{F}$;
- c. $23^{\circ}\text{F} \leq T_{\text{outdoor ambient}} < 28.4^{\circ}\text{F}$, $T_{\text{outdoor tube}} \leq 17.6^{\circ}\text{F}$;
- d. $14^{\circ}\text{F} \leq T_{\text{outdoor ambient}} < 23^{\circ}\text{F}$, $T_{\text{outdoor tube}} - T_{\text{compensatory}} \leq (T_{\text{outdoor ambient}} - 5.4^{\circ}\text{F})$
- e. $T_{\text{outdoor ambient}} < 14^{\circ}\text{F}$, $T_{\text{outdoor tube}} - T_{\text{compensatory}} \leq (T_{\text{outdoor ambient}} - 5.4^{\circ}\text{F})$

After energization, for the first defrosting, $T_{\text{compensation}} = 0^{\circ}\text{F}$; if it is not the first time of defrosting, $T_{\text{compensation}}$ will be determined by

$T_{\text{outdoor pipe}}$ when quitting defrosting last time;

- a. $T_{\text{outdoor pipe}} > 35.6^{\circ}\text{F}$, $T_{\text{compensation}} = 0^{\circ}\text{F}$;
- b. $T_{\text{outdoor pipe}} \leq 35.6^{\circ}\text{F}$, $T_{\text{compensation}} = 5.4^{\circ}\text{F}$.

(3) During defrosting, if operation time for compressor doesn't reach 3min, the defrosting will not be entered in the subsequent 2 hours. At that time, compressor stops operation and in 30s later, the outdoor fan will stop operation; in another 30s, 4-way valve will stop operation; in 30s later, compressor will increase its frequency for defrosting. When defrosting lasts for 450s, or $T_{\text{outdoor pipe}} \geq 50^{\circ}\text{F}$, compressor will decrease its frequency. In 30s later, compressor will stop operation; in another 30s, 4-way valve will be started up. In 60s later, compressor and outdoor fan will operate. Frequency for defrosting is 85Hz.

3. Protection

◆ Cold air prevention

The unit is started under heating mode (the compressor is ON):

1. In the case of $T_{\text{indoor amb.}} < 75.2^{\circ}\text{F}$: if $T_{\text{tube}} \leq 104^{\circ}\text{F}$ and the indoor fan is at stop state, the indoor fan will begin to run at low speed with a time lag of 2 minutes. Within 2 minutes, if $T_{\text{tube}} > 104^{\circ}\text{F}$, the indoor fan also will run at low speed; and after 1-minute operation at low speed, the indoor fan will be converted to operation at preset speed. Within 1-minute low speed operation or 2-minute nonoperation, if $T_{\text{tube}} > 107.6^{\circ}\text{F}$, the fan will run at present speed.

2. In the case of $T_{\text{indoor amb.}} \geq 75.2^{\circ}\text{F}$: if $T_{\text{tube}} \leq 107.6^{\circ}\text{F}$, the indoor fan will run at low speed, and after one minute, the indoor fan will be converted to preset speed. Within one-minute low speed operation, if $T_{\text{tube}} > 107.6^{\circ}\text{F}$, the indoor fan will be converted to preset speed.

Note: $T_{\text{indoor amb.}}$ indicated in 1 and 2 refers to, under initially heating mode, the indoor ambient temperature before the command to start the compressor is performed according to the program, or after the unit is withdrawn from defrost, the indoor ambient temperature before the defrost symbol is cleared.

Product Introduction

Basic Functions - 9K & 12K 230 volt

◆ Total current up and frequency down protection

When total current $I_{total} \leq 6A$, increase frequency is allowed; when total current $I_{total} \geq 7A$, increasing frequency is prohibited; when total current $I_{total} \geq 8A$, the unit operates by decreasing frequency. When total current $I_{total} \geq 9A$, the compressor stops operation, and indoor fan will stop operation after 30s.

(4) Fan Mode

Under the mode, the indoor fan will run at preset speed and the compressor, the outdoor fan, the four-way valve and the electric heater will stop. Under the mode, temperature can be set within a range of 61 - 86°F.

(5) AUTO Mode

1. Working conditions and process of AUTO mode

a. When $T_{ambient} \geq 78.8^\circ F$, the unit will operate in Cool mode. The set temperature is 77°F.

b. When $T_{ambient} \leq 71.6^\circ F$, the heat pump unit will operate in Heat mode., set temperature be 68°F; the cooling only unit will operate in Fan mode, set temperature be 77°F.

c. When $73.4^\circ F \leq T_{ambient} \leq 77^\circ F$, the unit will operate in the previous state. If it is energized for the first time, it will operate in Fan mode.

d. Under auto mode, if it's cooling mode, operation frequency is same as that under cooling mode; if it's heating mode, operation frequency is same as that under heating mode.

2. Protection

a. In cooling operation, protection is the same as that under the cooling mode;

b. In heating operation, protection is the same as that under the heating mode;

c. When ambient temperature changes, operation mode will be converted preferentially. Once started, the compressor will remain unchanged for at least 6 minutes.

(6) Common Protection Functions and Fault Display under COOL, HEAT, DRY and AUTO Modes

1. Overload protection

T tube: measured temperature of outdoor heat exchanger under cooling mode; and measured temperature of indoor heat exchanger under heating mode.

1) Cooling overload

a. If $T_{tube} \leq 125.6^\circ F$, the unit will return to its original operation state.

b. If $T_{tube} \geq 131^\circ F$, frequency rise is not allowed.

c. If $T_{tube} \geq 136.4^\circ F$, the compressor will run at reduced frequency.

d. If $T_{tube} \geq 143.6^\circ F$, the compressor will stop and the indoor fan will run at preset speed.

2) Heating overload

a. If $T_{tube} \leq 122^\circ F$, the unit will return to its original operation state.

b. If $T_{tube} \geq 127.4^\circ F$, frequency rise is not allowed.

c. If $T_{tube} \geq 132.8^\circ F$, the compressor will run at reduced frequency.

d. If $T_{tube} \geq 140^\circ F$, the compressor will stop and the indoor fan will blow residue heat and then stop.

2. Exhaust temperature protection of compressor

If exhaust temperature $\geq 208.4^\circ F$, frequency is not allowed to rise.

If exhaust temperature $\geq 217.4^\circ F$, the compressor will run at reduced frequency.

If exhaust temperature $\geq 230^\circ F$, the compressor will stop.

If exhaust temperature $\leq 194^\circ F$ and the compressor has stayed at stop for at least 3 minutes, the compressor will resume its operation.

3. Communication fault

If the unit fails to receive correct signals for durative 3 minutes, communication fault can be justified and the whole system will stop.

4. Module protection

Under module protection mode, the compressor will stop. When the compressor remains at stop for at least 3 minutes, the compressor will resume its operation. If module protection occurs six times in succession, the compressor will not be started again.

Product Introduction

Basic Functions - 9K & 12K 230 volt

5. Overload protection

If temperature sensed by the overload sensor is over 239°F, the compressor will stop and the outdoor fan will stop with a time lag of 30 seconds. If temperature is below 203°F, the overload protection will be relieved.

6. DC bus voltage protection

If voltage on the DC bus is below 150V or over 420V, the compressor will stop and the outdoor fan will stop with a time lag of 30 seconds. When voltage on the DC bus returns to its normal value and the compressor has stayed at stop for at least 3 minutes, the compressor will resume its operation.

3. Other Controls

(1) ON/OFF

Press the remote button ON/OFF: the on-off state will be changed once each time you press the button.

(2) Mode Selection

Press the remote button MODE, then select and show in the following ways: AUTO, COOL, DRY, FAN, HEAT, AUTO.

(3) Temperature Setting Option Button

Each time you press the remote button TEMP+ or TEMP-, the setting temperature will be up or down by 1.8°F. Regulating Range: 61 - 86°F, the button is useless under the AUTO mode.

(4) Time Switch

You should start and stop the machine according to the setting time by remote control.

(5) SLEEP function

Sleep mode is only valid under cooling mode and heating mode;

Cooling mode: Basing on the set temperature of remote controller, after turning on the sleep function for a few hours, set temperature will increase properly and automatically according to human body's comfort.

Heating mode: Basing on the set temperature of remote controller, after turning on the sleep function for a few hours, set temperature will decrease properly and automatically according to human body's comfort.

(6) Indoor Fan Control

The Indoor Fan can be set as HIGH, MED, LOW by remote control, and the Indoor Fan will be respectively run at high, medium, low speed. It will also be set as AUTO, and the Indoor Fan is as the followings at the automatic wind speed.

Cooling mode:

$T_{ring} \geq T_{setting} + 3.6^{\circ}\text{F}$, high speed;

$T_{setting} - 3.6^{\circ}\text{F} < T_{ring} < T_{setting} + 3.6^{\circ}\text{F}$, medium speed;

$T_{ring} \leq T_{setting} - 3.6^{\circ}\text{F}$, low speed.

Sending wind mode:

$T_{ring} > T_{setting} + 7.2^{\circ}\text{F}$, high speed;

$T_{setting} + 3.6^{\circ}\text{F} \leq T_{ring} \leq T_{setting} + 7.2^{\circ}\text{F}$, medium speed;

$T_{ring} < T_{setting} + 3.6^{\circ}\text{F}$, low speed.

Moisture removal mode: force to be set as the low speed

Heating mode:

$T_{ring} \leq T_{setting} + 1.8^{\circ}\text{F}$, high speed;

$T_{setting} + 1.8^{\circ}\text{F} < T_{ring} < T_{setting} + 9^{\circ}\text{F}$, medium speed;

$T_{ring} \geq T_{setting} + 3.6^{\circ}\text{F}$, low speed.

Product Introduction

Basic Functions - 9K & 12K 230 volt

(7) Buzzer Control

The buzzer will send a “Di” sound when the air conditioner is powered up or received the information sent by the remote control or there is a button input, the single tube cooler doesn’t receive the remote control ON signal under the mode of heating mode.

(8) Auto button

If the controller is on, it will stop by pressing the button, and if the controller is off, it will be automatic running state by pressing the button, swing on and light on, and the main unit will run based on the remote control if there is remote control order.

(9) Up-and-Down Swinging Control

When power on, the up-and-down motor will firstly move the air deflector to counter-clockwise, close the air outlet. After starting the machine, if you don’t set the swinging function, heating mode and auto-heating mode, the up-and-down air deflector will move to

D clockwise; under other modes, the up-and-down air deflector will move to L1. If you set the swinging function when you start the machine, then the wind blade will swing between L and D. The air deflector has 7 swinging states: Location L, Location A, Location

B, Location C, Location D, Location L to Location D, stop at any location between L-D (the included angle between L~D is the same). The air deflector will be closed at 0 Location, and the swinging is effectual only on condition that setting the swinging order and the inner fan is running. The indoor fan and compressor may get the power when air deflector is on the default location.

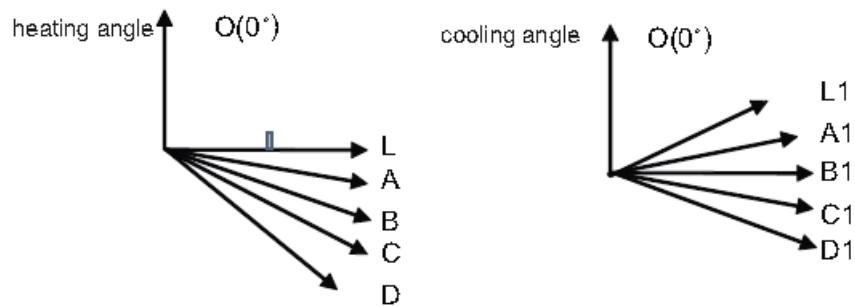

(10) Display

1. Operation pattern and mode pattern display

All the display patterns will display for a time when the power on, the operation indication pattern will display in red under standby status. When the machine is start by remote control, the indication pattern will light and display the current operation mode (the mode light includes: Cooling, heating and dehumidify). If you close the light key, all the display patterns will close.

2. Double-8 display

According to the different setting of remote control, the nixie light may display the current temperature (the temperature scope is from 61 to 86°F) and indoor ambient temperature. The heating and air supply temperature will display 77°F under auto-mode, the temperature will display 64.4°F, under the heating mode, heating indicator on indoor unit will ON 10s and OFF 0.5s successively under the defrosting mode.(If you set the Fahrenheit temperature display, the nixie light will display according to Fahrenheit temperature)

Product Introduction

Basic Functions - 9K & 12K 230 volt

(11) Drying Function

You may start or stop the drying function under the modes of cooling and dehumidify at the starting status (The modes of automatism, heating and air supply do not have drying function). When you start the drying function, after stop the machine by pressing the switch button, you should keep running the inner fans for 2 minutes under low air damper (The swing will operate as the former status within 2 minutes, and other load is stopped), then stop the entire machine; When you stop the drying function, press the switch button will stop the machine directly. When you start the drying function, operating the drying button will stop the inner fans and close the guide louver.

(12) Memory function when interrupting the power supply

Memory content: mode, swing function, light, set temperature and wind speed. After interrupted the power supply, the machine will start when recovering the power according to the memory content automatically. If the last remote control command has not set the timed function, the system will remember the last remote control command and operate according it. If the last remote control command has set timed function and the power supply is interrupted before the timed time, the system will remember the timed function of the last remote control command, the timed time will recounted form power on. If the last remote control command has set timed function, the time is out and the system is start or stop according to the set time when the power supply is interrupted, the system will remember the operation status before the power supply was interrupted, and do not carry out timed action; The timed clock will not remembered.

(13) CONTROL OF OUTDOOR ELECTRIC HEATING BAND

If not in heating mode or temp sensor has malfunction, electric heating bands of compressor and of condenser will stop operation, otherwise, the below control logic will be followed.

1. Control of Compressor Electric Heating Band

a) Startup condition: compressor is powered off while outdoor ambient temperature $\leq 23^{\circ}\text{F}$;

b) Stop condition: the compressor will be turned off under any of the condition;

i. Compressor is powered on:

ii. Compressor is powered off while outdoor ambient temperature $\geq 28.4^{\circ}\text{F}$;

c) Outdoor ambient temp. sensor is with malfunction, the electric heating band will stop operation.

2. Condenser electric heating band control

1) When $T_{\text{outdoor ambient}} \leq 33.8^{\circ}\text{F}$, the condenser electric heating band will start operation;

2) The chassis electric heating band will operate during the course from the unit starts defrosting to defrosting finished and the compressor start operation, after 3mins operation of compressor and $T_{\text{outdoor ambient}} \geq 37.4^{\circ}\text{F}$, electric heating stop operation.

3) When $T_{\text{outdoor ambient}} \geq 37.4^{\circ}\text{F}$, condenser electric heating band stop operation.

4) When $33.8^{\circ}\text{F} < T_{\text{outdoor ambient}} < 37.4^{\circ}\text{F}$, condenser electric heating band keep its original status.

When there's malfunction of outdoor ambient temp. sensor, the electric heating band stop operation and restart operation 2mins later.

(14) Compulsory defrosting function

(1) Start up compulsory defrosting function

Under ON status, set heating mode with remote controller and adjust the temperature to 16°C . Press “+, -, +, -, +,-” button successively within 5s and the complete unit will enter into compulsory defrosting status. Meanwhile, heating indicator on indoor unit will ON 10s and OFF 0.5s successively. (Note: If complete unit has malfunction or stops operation due to protection, compulsory defrosting function can be started up after malfunction or protection is resumed.

(2) Exit compulsory defrosting mode

After compulsory defrosting is started up, the complete unit will exit defrosting operation according to the actual defrosting result, and the complete unit will resume normal heating operation.

Product Introduction

Basic Functions - 9K & 12K 230 volt

(15) Refrigerant recovery function (applicable for moving the unit or maintaining the unit)

(1) Start up refrigerant recovery function

Set cooling mode with remote controller within 5min after energization, adjust temperature at 16OC and press light button on remote controller for 3 times successively to any one indoor unit within 3s and then the complete unit will enter into refrigerant recovery status. All indoor units display Fo. Maintenance person close all liquid valves. After 5min, withstand the thimble of all checking valves with tools one by one. If there's no refrigerant spraying out, close corresponding valve immediately, turn off the unit with remote controller and then remove the connection pipe.

(2) Exit refrigerant recovery function

During refrigerant recovery process, if any one indoor unit receives any remote control signal or refrigerant recovery function has operates for about 25min, refrigerant recovery function will be exited automatically. If the complete unit is at standby status before refrigerant recovery, the complete unit will still at standby status after refrigerant recovery. If the complete unit is at ON status, the unit will operate according to original operation mode.

(3) After entering refrigerant recovery function: Indoor unit operates at cooling mode. Fan speed is super-high speed and set temperature is 16°C. Horizontal will open at the minimum operation angle.

Product Introduction

Basic Functions - 18K & 24K 230 volt

Indoor Unit

A. Basic function of system

(1) Cooling mode

1. Under this mode, fan motor, swing will work under setting status, the temp. range is 61-86
2. Outdoor unit malfunction or unit stop running, indoor unit will keep original running status, malfunction displayed.
3. When $0(T_{set}-T_{amb})$, if indoor fan motor is high speed, that the fanmotor is running in middle speed, the middle speed or low speed will be maintained;(this condition should be executed when compressor start up);the super high speed will not rotate; When $(T_{amb}-T_{set}) \geq 33.8^{\circ}\text{F}$ the fan will return to the setting fan speed.

(2) Drying mode

1. Under this mode, fan motor will run at low speed, swing will work at setting status ,setting temp. range is 61-86 °F.
2. Outdoor unit malfunction or protection, unit will stop, indoor unit will keep original running status, malfunction displayed.

(3) Fan mode

Under this mode ,indoor fan motor could be set at high, middle, low or auto speed, compressor, outdoor unit and valve will stop to run. Under this mode, temp. range should be 61-86 °F.

(4) Heating mode

1. Under this mode, temp. range should be 61-86 °F.
2. Working condition and procedure of heating mode: When unit turn on and enter into Heating mode, indoor unit enter into anti-cool wind mode, when unit is stop running, and indoor fan motor turns on, blowing heat will act.
3. Protection function, under heating mode, compressor will stop to run due to malfunction happened, indoor fan motor will blow surplus heat.
4. Defrosting control: When receiving the defrosting signal from outdoor unit, displayer will display H1,10s later, indoor fan motor will stop to run.
5. Anti-cold wind function
6. Blow heat air function
 - a. If heating temp. meets the compressor stop running condition, compressors, outdoor fan motor will stop to run, the upper and lower guide louver will rotate to horizontal position L, indoor fan motor run at setting fan speed for 60s, then the indoor fan motor will stop to run.
 - b. Due to block running, the air guide board will keep the position when it stopping. (under each mode), other malfunction unit will stop to run, the upper and lower air guide louver will rotate to horizontal position, indoor fan unit will run at setting fan speed and run for 60s, indoor fan unit will stop to run.

(5) Auto mode

1. When $T_{amb} \geq 78.8^{\circ}\text{F}$, select the cooling mode, at this time, the setting temp. is 77 °F.
2. Cooling and heating units: $T_{amb} \leq 71.6^{\circ}\text{F}$, will run at heating mode, at this time, the setting temp. is 68-73 °F.
3. Cooling only unit: When $T_{amb} \leq 71.6^{\circ}\text{F}$, it will run at Fan mode, the setting temp. is 77 °F.
4. When $73.4^{\circ}\text{F} \leq T_{indoor\ amb.} \leq 77^{\circ}\text{F}$, firstly enter into auto mode and run at auto fan speed, other modes will run at auto mode, will keep the previous running mode. (When entering into dehumidifying mode, it will run at auto fan speed)

Product Introduction

Basic Functions - 18K & 24K 230 volt

B. Display state of indoor indicators

(1) State of indoor display board

1. When the unit is powered on, all patterns will be displayed and then only power indicator is on. When the unit is turned on with a remote controller, the operating indicator is on and operation mode which is set currently is displayed.

2. In defrosting mode, "H1" is displayed on "Double 8".

3. Set temperature is displayed on "Double 8".

- Display of operation patterns and mode patterns

When the unit is powered on, all patterns will be displayed and the standby operation indicator will become red.

When the unit is turned on through a remote controller, the operation indicator is light. At the same time, operating mode patterns (mode indicators include cooling, heating and dehumidification modes) set currently are displayed, and dynamic display patterns of wind speed are displayed. If the light button is switched off, all display will be turned off.

- Temperature display control mode of separated air conditioner
- When user sets the remote controller at set temperature display, currently set temperature will be displayed.
- Only when remote signals are converted from other display states into indoor ambient temperature display state, the remote controller will display indoor ambient temperature for 5 seconds and then return to set temperature display.
- Only when remote signals are converted from other display states into outdoor ambient temperature display state, the remote controller will display outdoor ambient temperature for 5 seconds and then return to set temperature display.
- If the controller is lack of outdoor display functions, as the signal is received, set temperature will be displayed.
- When the unit is turned off, temperature display will be compulsively set at given temperature by the controller. When the unit is turned on, patterns as set by remote signals will be displayed.
- If user does not set up temperature display state, given temperature will be displayed.

(2) Failure display of indoor unit

1. Requirements for failure display when multiple failures appear at the same time, failure protection codes shall be displayed alternatively. Hardware failures shall be displayed immediately, referring to requirements in "Failure State Display Table";

- Operation states shall be displayed immediately, referring to requirements in "Failure State Display Table";
- Other failures shall be displayed 200s after the compressor stops, referring to requirements in "Failure State Display Table".(Note: in the case that the unit is switched off with the remote controller, or the compressor is switched on again, failure display waiting time (200s) shall be cleared.)
- Frequency limitation and reduction states shall be displayed by means of remote calling.

2. Failure display control Indicator failure display shall be kept synchronous with Double 8 failure display, that is, during indicator blinking, failure code corresponding to such indicator shall be displayed on Double 8.

3. Method of remote calling of failure display

Entering the failure remote calling mode: push the light button four times within 3s to call out relevant failure protection code; Quit the failure remote calling mode: push the light button four times within 3s or call out failure display to enter it for 5 minutes and then quit.

4. Other control targets

Product Introduction

Basic Functions - 18K & 24K 230 volt

(1) Up and down wind blow functions

When the unit is powered on, the up and down wind blow motor will turn a wind deflector anti-clockwise to Position 0 to shut down the air outlet. When the unit is switched on and wind blow function is not preset, under the heating mode, up and down wind blades will turn clockwise to position D; and under other modes, the up and down wind blades will turn clockwise to position L. If wind blow function is set at the same time as the unit is switched on, the wind blades will swing between position L and D. The wind blades can be kept in seven states: position L, position A, position B, position C, position D, swing between position L and D, stop at one position from L to D. When the unit is turned off, the wind deflector will be closed up to position 0. Wind blow action is effective only when wind blow commands are set and the indoor unit is running.

Note: When the wind blades are set at position L to B, position A to C, or position B to D through remote setting, the wind deflector will swing between position L and D. L—A—B—C—D.

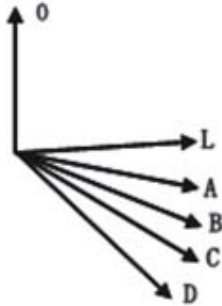

(2) Buzzer

When the controller is powered on, signals from a remote controller are received, or the auto button is pushed, a buzzer will give out prompt tone.

(3) Auto button

When the button is pushed, the unit will operate in auto mode and the indoor fan will run in auto state. When the indoor fan is running, the wind blow motor will work. When the button is pushed again, the unit will be switched off. At the same time as the button is pushed, the whole unit will be powered on and enter into fast test mode; when the unit is powered on and detects for continuous 20s (such time shall not be fast tested) that the auto button is pushed, and if the unit is currently at fast test state, the unit will quit the fast test state.

(4) Sleep function

In this mode, the unit will select the suitable sleep curve to run according to the different setting temperature.

(5) Timing function

The main board integrates general timing and moment timing. Such two timing functions can be selected through a remote controller on which different functions are arranged.

1. General timing:

Timing start: timing start can be set when the unit is off. When preset time is reached, the controller will operate in a preset mode. Timing can be set at an interval of 0.5 hour in a scope of 0.5 - 24 hours.

Timing stop: timing stop can be set when the unit is on. When preset time is reached, the system will be turned off.

Timing can be set at an interval of 0.5 hour in a scope of 0.5 - 24 hours.

2. Moment timing

Timing start: if timing start is set when the system is at operation state, the system will continue to operate; if timing start is set when the system is at stop, as the preset time is reached, the system will start to run in preset mode. Timing stop: if timing stop is set when the system is at stop state, the system will keep standby; if timing stop is set when the system is in operation, as the preset time is reached, the system will stop running.

Product Introduction

Basic Functions - 18K & 24K 230 volt

Timing change:

When the system is in timing mode, start and stop can be set through the On/Off button on the remote controller; or timing time can be reset and the system will operate according to the latest setting. When the system is in operation and both timing start and stop are set, the system will stay at currently set operation state. When preset timing stop time is reached, the system will stop working. When the system is at stop state and both timing start and stop are set, the system will keep at stop state. When preset timing start time is reached, the system will start operation. From then on, the system will operate in preset mode at a preset start time and stop at a preset stop time every day. If timing stop time is set as the same as timing start time, a stop command will be executed.

(6) Dry and mildew proof function

Dry and mildew proof function can be set in cooling and dehumidification modes.

(7) Control of indoor fan

Indoor fan can be set at four levels, super-high, high, middle and low, with a remote controller. When one level is set, the fan will thus operate at such level. The fan can also be set at auto state.

(8) Power-failure memory function

What will be memorized includes modes, up and down wind blow, light, preset temperature, preset wind speed, general timing (no Memory for moment timing), and Fahrenheit /Celsius degree. When the unit is powered on again after power failure, operation continues according to memorized content. If timing is not set by the last remote control command, the system will memorize the last remote control command and operate in the mode specified in the last remote control command. If timing is set by the last remote control command and power failure happens before the preset time, the system, as powered on again, will memorize the timing function set by the last remote control command. Timing will be re-counted from the time at which the system is powered again. If timing is set by the last remote control command and timing of start or stop is reached before power failure, the system, as powered on again, will memorize operation state before power failure and will not perform timing action. Moment timing is out the range of memory.

(9) Locked Protection

When starting up the fans, if the motor has run at a lower speed continuously for a period, for preventing automatic protection of the motor, stop running, and display the locked operation; if the machine is running at present, the code of the locked fault---H6 of double-eight digital tubes will be displayed; if the machine is shut down at present, the information of the locked fault will not be displayed.

(10) Super Power Function

In cooling and heating modes (automatic, dehumidifying and air-supplying modes are without strong power), press the button of Super Power, the wind speed on the remote controller is displayed as super-high air flow, and the inner fans are also turned to super-high air flow;

(11) Health Function

When the inner fans are running, the remote controller is set at the Health function at this time (if there is no Health button on the remote controller, the Health On order is defaulted), then start the Health function device.

3. Fault Detection of Thermo-bulb

(1) Indoor Environment Thermo-bulb: Detect the fault of thermo-bulb at any time;

(2) Indoor Pipe Temperature Thermo-bulb: During the defrosting period, the fault of the thermo-bulb will be not detected, which shall be detected in 5 minutes after defrosting is completed; the fault of the thermo-bulb will be detected at other times;

(3) Protecting Treatments of Thermo-bulb

1. When the thermo-bulb is detected to be short-circuited continuously for 30 seconds: It is regarded that the temperature detected by the thermo-bulb is over-high (or unlimited), then the whole machine will exert corresponding safety stops according to the over-high temperature sensed by the thermo-bulb, and display corresponding temperature safety stops and faults of the thermo-bulb simultaneously.

Product Introduction

Basic Functions - 18K & 24K 230 volt

2. When the thermo-bulb is detected in open circuit continuously for 30 seconds: stop the machine in protection, directly display corresponding faults of the thermo-bulb.

3. Forced Running Function of the Indoor Units

(1) Enter into Forced Running Control Within 5 minutes after power-up, press the Lights Off button on the remote controller continuously for three times within 3 seconds to enter into the fluorine collecting mode, and display Fo, send the fluorine-collecting mode for 25 minutes continuously, each load will be treated as cooling when starting the machine (set the air flow as High, set the temperature as 60.8 °F).

(2) Exit from the Forced Running Control After receiving any remote signal, or signal of keys, the fluorine-collecting mode will exit, and operate in accordance with the current orders set; or exit the fluorine-collecting mode after running for 25 minutes, and the machine will be shut down automatically.

Product Introduction

Basic Functions - 18K & 24K 230 volt

Outdoor Unit

A. Input Parameter Compensation and Calibration

(1) Check the ambient temperature compensation function

Indoor ambient temperature compensation function

a. In cooling mode, the indoor ambient temperature participating in computing control = (Tindoor ambient temperature - $\Delta T_{\text{cooling}}$ indoor ambient temperature compensation)

b. In heating mode, the indoor ambient temperature participating in computing control = (Tindoor ambient temperature - $\Delta T_{\text{heating}}$ indoor ambient temperature compensation)

(2) Check effective judgment controls of parameters

Effective judgment function of the outdoor exhaust temperature thermo-bulb When conditions a and b are satisfied, the outdoor exhaust temperature thermo-bulb is judged not to be connected into place, the main board of outer units will display failure of the outdoor exhaust temperature thermo-bulb (not connected into place), stop the machine for repairing, and resume the machine by remote controls of ON/OFF.

a. Judgment of exhaust detection temperature change: After the compressor starts up and runs for 10 minutes, if the compressor frequency $f \geq 40\text{Hz}$, and the rising value T_{exhaust} (T_{exhaust} (after start-up for 10 minutes) - T_{exhaust} (before start-up)) $< 35.6^\circ\text{F}$, the outdoor exhaust temperature thermo-bulb can be judged not to be connected into place (judging once when the power is on the first time).

b. Comparative judgment of exhaust detection temperature and condenser detection temperature (T_{pipe} temperature = $T_{\text{outdoor pipe}}$ temperature in cooling mode, T_{pipe} temperature = $T_{\text{indoor pipe}}$ temperature in heating mode): After the compressor starts up and runs for 10 minutes, if the compressor frequency $f \geq 40\text{Hz}$, and T_{pipe} temperature $\geq (T_{\text{exhaust}} + 37.4^\circ\text{F})$, the outdoor exhaust temperature thermo-bulb can be judged not to be connected into place (judging once when power is on the first time).

B. Basic Functions

(1) Cooling Mode

1. Conditions and processes of cooling operation:

(1) If the compressor is shut down, and $[T_{\text{setup}} - (T_{\text{indoor ambient temperature}} - \geq T_{\text{cooling indoor ambient temperature compensation}})] \leq 32.9^\circ\text{F}$, start up the machine for cooling, the cooling operation will start;

(2) During operations of cooling, if $32^\circ\text{F} \leq [T_{\text{setup}} - (T_{\text{indoor ambient temperature}} - \Delta T_{\text{cooling indoor ambient temperature compensation}})] < 35.6^\circ\text{F}$, the cooling operation will be still running;

(3) During operations of cooling, if $32^\circ\text{F} \leq [T_{\text{setup}} - (T_{\text{indoor ambient temperature}} - \Delta T_{\text{cooling indoor ambient temperature compensation}})]$, the cooling operation will stop after reaching the temperature point.

2. Temperature setting range

(1) If $T_{\text{outdoor ambient temperature}} \geq [T_{\text{low-temperature cooling temperature}}]$, the temperature can be set at: $60.8\sim 86^\circ\text{F}$ (Cooling at room temperature);

(2) If $T_{\text{outdoor ambient temperature}} < [T_{\text{low-temperature cooling temperature}}]$, the temperature can be set at: $77\sim 86^\circ\text{F}$ (Cooling at low temperature), that is, the minimum setting temperature for outer unit's judgment is 77°F .

(2)Drying Mode

1. Conditions and processes of drying operations: Same as the cooling mode;

2. The temperature setting range is: $60.8\sim 86^\circ\text{F}$;

(3) Air-supplying Mode

1. The compressor, outdoor fans and four-way valves are switched off;

2. The temperature setting range is: $60.8\sim 86^\circ\text{F}$.

Product Introduction

Basic Functions - 18K & 24K 230 volt

(4) Heating Mode

1. Conditions and processes of heating operations: (Tindoor ambient temperature is the actual detection temperature of indoor environment thermo-bulb, $\Delta T_{\text{heating indoor ambient temperature compensation}}$ is the indoor ambient temperature compensation during heating operations)

(1) If the compressor is shut down, and $[(T_{\text{indoor ambient temperature}} - \Delta T_{\text{heating indoor ambient temperature compensation}}) - T_{\text{setup}}] \leq 32.9^{\circ}\text{F}$, start the machine to enter into heating operations for heating;

(2) During operations of heating, if $32^{\circ}\text{F} \leq [(T_{\text{indoor ambient temperature}} - \Delta T_{\text{heating indoor ambient temperature compensation}}) - T_{\text{setup}}] < 35.6^{\circ}\text{F}$, the heating operation will be still running;

(3) During operations of heating, if $35.6^{\circ}\text{F} \leq [(T_{\text{indoor ambient temperature}} - \Delta T_{\text{heating indoor ambient temperature compensation}}) - T_{\text{setup}}]$, the heating operation will stop after reaching the temperature point.

2. The temperature setting range in this mode is: 60.8-86°F

C. Special Functions

Defrosting Control

a. Conditions for starting defrosting

After the time for defrosting is judged to be satisfied, if the temperature for defrosting is satisfied after detections for continuous 3minutes, the defrosting operation will start.

b. Conditions of finishing defrosting

The defrosting operation can exit when any of the conditions below is satisfied

c. $T_{\text{outdoor pipe temperature}} \geq (T_{\text{outdoor ambient temperature}} - [T_{\text{temperature 1 of finishing defrosting}}])$;

d. The continuous running time of defrosting reaches $[t_{\text{max. defrosting time}}]$.

D. Control Logic

(1) Compressor Control

Start the compressor after starting cooling, heating, dehumidifying operations, and the outer fans start for 5s; when the machine is

shut down, in safety stops and when switching to air-supplying mode, the compressor will stop immediately.

In all modes: once the compressor starts up, it will not be allowed to stop until having run for the $[t_{\text{min. compressor running time}}]$ (Note: including cases of shutdown when the temperature point is reached; except the cases requiring stopping the compressor such as fault protection, remote shutdown, mode switching etc.);

In all modes: once the compressor stops, it will be allowed be restart after 3-minute delay (Note: The indoor units have a function of power memory, the machine can be restarted after remote shutdown and powering up again without delay).

1. Cooling mode

Start the machine to enter into cooling operation for cooling, the compressor is switched on.

2. Drying mode

Same as the cooling mode.

3. Air-supplying mode

The compressor is switched off.

4. Heating mode

(1) Start the machine to enter into heating operation for heating, the compressor is switched on.

(2) Defrosting:

a. Defrosting starts: the compressor is shut down, and restarts it after 55-second delay.

b. Defrosting ends: the compressor stops, and then starts it after 55-second delay.

Product Introduction

Basic Functions - 18K & 24K 230 volt

(2) Outer Fans Control

Notes:

Only the outer fans run for at least 80s in each air flow speed can the air flow be switched; after the outer fans run compulsively in high speed for 80s when the machine starts up, control the air flow according to the logic. After remote shutdown, safety stops, and when the machine stops after reaching the temperature point, as well as after the compressor stops, extend 1 minute, the outer fans will stop (During the period in the 1 minute, the air flow of outer fans can be changed according to the outdoor ambient temperature changes); when running with force, the outdoor fans shall run in the highest air flow.

(3) 4-way valve control

1. The 4-way valve control under the modes of Cooling, dehumidification and supplying air: closing;

2. The status of 4-way valve control under the heating mode: getting power;

(1) 4-way valve power control under heating mode a. Starts the machine under heating mode, the 4-way valve will get power immediately.

(2) 4-way valve power turn-off control under heating mode a. When you should turn off the power or switch to other mode under heating mode, the power of 4-way valve will be cut after 2 minutes of the compressor stopped. b. When all kinds of protection stops, the power of 4-way valve will be cut after delaying 4 minutes.

(3) Defrosting control under heating mode: a. Defrosting begins: The power of 4-way valve will be cut after 50s of entering into the defrosting compressor.

b. Defrosting stops: The 4-way valve will get power after 50s of exiting the defrosting compressor.

(4) Evaporator frozen-preventing protection function At the mode of Cooling, dehumidifying:

Evaporator frozen-preventing protection function is allowed to begin after 6 min of starting the compressor.

1. Starting estimation: After the compressor stopped working for 180s, if Tinner pipe > Tfrozen-preventing frequency-limited temperature (the temperature of hysteresis is 35.6°F), the machine is only allowed to start for operating, otherwise it should not be started, and should be stopped to treat according to the frozen-preventing protection: Clear the trouble under the mode of power turn-off / heating, and the protection times are not counted.

2. Frequency limited

[Tfrozen-preventing normal speed frequency-reducing temperature] ≤ Tinner pipe < [Tfrozen-preventing frequency-limited temperature], you should limit the frequency **rising of compressor**.

3. Reducing frequency at normal speed

If [Tfrozen-preventing high speed frequency-reducing temperature] Tinner pipe < [Tfrozen-preventing normal speed frequency-reducing temperature] you should adjust the compressor frequency by reducing 8Hz/90s till the lower limit;

4. Reducing frequency at high speed

If [Tfrozen-preventing power turn-off temperature] ≤ Tinner pipe < [Tfrozen-preventing high speed frequency-reducing temperature] you should adjust the compressor frequency by reducing 30Hz/90s till the lower limit;

5. Power turn-off

If the T inner pipe < [Tfrozen-preventing power turn-off temperature], then frozen-preventing protect to stop the machine; If

[Tfrozen-preventing frequency-limited temperature] < T inner pipe, and the compressor has stopped working for 3 minutes, the whole machine should be allowed to operate.

6. If the frozen-preventing protection power turn-off continuously occurs for six times, it should not be resumed automatically, and you should press the ON/OFF button to resume if the fault keeps on. During the process of running, if the running time of compressor exceeds the [tevaporator frozen-preventing protection times zero clearing time], the times of frozen-preventing power turn-off should be cleared to recount. The mode of stopping the machine or transferring to supply air will clear the trouble times immediately (if the trouble cannot be resumed, mode transferring will not clear it).

Product Introduction

Basic Functions - 18K & 24K 230 volt

(5) Overload protection function

Overload protection function at the mode of Cooling and dehumidifying

1. Starting estimation: After the compressor stopped working for 180s, if Touter pipe < [TCooling overload frequency-limited temperature] (the temperature of hysteresis is 35.6 °F), the machine is allowed to start, otherwise it should not be started, and should be stopped to treat according to the overload protection: Clear the trouble at the mode of power turn-off / heating, and the protection times are not counted.

2. Frequency limited If [TCooling overload frequency-limited temperature ≤ Touter pipe < [TCooling overload frequency reducing temperature at normal speed], you should limit the frequency raising of compressor.

3. Reducing frequency at normal speed and power turn-off:

If [TCooling overload frequency reducing temperature at high speed] ≤ Touter pipe < [TCooling overload power turn-off temperature], you should adjust the compressor frequency by reducing 8Hz/90s till the lower limit; After it was running 90s at the lower limit, if [TCooling overload frequency reducing temperature at normal speed] ≤ Touter pipe, then Cooling overload protects machine stopping;

4. Reducing frequency at high speed and stop machine

If [TCooling overload frequency reducing temperature at high speed] ≤ Touter pipe < [TCooling overload power turn-off temperature] you should adjust the compressor frequency by reducing 30Hz/90s till the lower limit; After it was running 90s at the lower limit, if [TCooling overload frequency reducing temperature at normal speed] ≤ Touter pipe, then Cooling overload protects machine stopping;

5. Power turn-off

If the [TCooling overload power turn-off temperature] ≤ Touter pipe, then Cooling overload protects machine stopping; If Touter pipe <

[TCooling overload frequency-limited temperature] and the compressor has been stopped working for 3 minutes, the machine should be allowed to operate.

6. If the Cooling overload protection power turn-off continuously occurs for six times, it should not be resumed automatically, and you should press the ON/OFF button to resume if the fault keeps on. During the process of running, if the running time of compressor

exceeds the [toverload protection times zero clearing time], the times of overload protection power turn-off should be cleared to recount. The mode of stopping the machine or transferring to supply air will clear the trouble times immediately (if the trouble cannot be resumed, transferring mode will not clear it).

Overload protection function at the mode of heating

Starting estimation

After the compressor stopped working for 180s, if Tinner pipe < [Theating overload frequency-limited temperature] (the temperature of hysteresis is 35.6 °F), the machine is allowed to start, otherwise it should not be started, and should be stopped to treat according to the overload protection: Clear the trouble at the mode of power turn-off / heating, and the protection times are not counted.

Product Introduction

Basic Functions - 18K & 24K 230 volt

1. Frequency limited

If $[T_{\text{heating overload frequency-limited temperature}}] \leq T_{\text{inner pipe}} < [T_{\text{heating overload frequency reducing temperature at normal speed}}]$, you should limit the frequency raising of compressor.

2. Reducing frequency at normal speed and stopping machine: If $[T_{\text{heating overload frequency reducing temperature at normal speed}}] \leq T_{\text{inner pipe}} <$

$[T_{\text{heating overload frequency reducing temperature at high speed}}]$, you should adjust the compressor frequency by reducing 8Hz/90s till the lower limit; After

it was running 90s at the lower limit, if $[T_{\text{heating overload frequency reducing temperature at normal speed}}] \leq T_{\text{inner pipe}}$, then overload protects machine stopping;

3. Reducing frequency at high speed and power turn-off: If $[T_{\text{heating overload frequency reducing temperature at high speed}}] \leq T_{\text{inner pipe}} <$

$[T_{\text{heating overload power turn-off temperature}}]$ you should adjust the compressor frequency by reducing 30Hz/90s till the lower limit; After it was

running 90s at the lower limit, if $[T_{\text{heating overload frequency reducing temperature at normal speed}}] \leq T_{\text{outer pipe}}$, then Cooling overload protects machine stopping;

4. Power turn-off: If the $[T_{\text{heating overload power turn-off temperature}}] \leq T_{\text{inner pipe}}$, then overload protects machine stopping; If $T_{\text{inner pipe}} <$

$[T_{\text{heating overload frequency-limited temperature}}]$ and the compressor has been stopped working for 3 minutes, the machine should be allowed to operate.

5. If the overload protection power turn-off continuously occurs for six times, it should not be resumed automatically, and you should

press the ON/OFF button to resume if the fault keeps on. During the process of running, if the running time of compressor exceeds the

$[T_{\text{overload protection times zero clearing time}}]$, the times of overload protection power turn-off should be cleared to recount. The mode of stopping the

machine or transferring to supply air will clear the trouble times immediately (if the trouble cannot be resumed, transferring mode will not

clear it).

Protective function for discharge temperature of compressor

1. Starting estimation:

After the compressor stopped working for 180s, if $T_{\text{Discharge}} < [T_{\text{Discharge limited temperature}}]$ (the temperature of hysteresis is 35.6°F), the machine

is allowed to start, otherwise it should not be started, and should be stopped to treat according to the discharge temperature: The machine

should be stopped or transferred to supply air, the trouble should be cleared immediately, and the protection times are not counted.

2. Frequency limited

If $[T_{\text{limited frequency temperature during discharging}}] \leq T_{\text{Discharge}} < [T_{\text{frequency reducing temperature at normal speed during discharging}}]$, you should limit the frequency raising of compressor.

Product Introduction

Basic Functions - 18K & 24K 230 volt

3. Reducing frequency at normal speed and stopping machine: If $[T_{\text{frequency reducing temperature at normal speed during discharging}}] \leq T_{\text{Discharge}} < [T_{\text{frequency reducing temperature at high speed during discharging}}]$ you should adjust the compressor frequency by reducing 8Hz/90s till the lower limit; After it was running 90s at the lower limit, if $[T_{\text{frequency reducing temperature at normal speed during discharging}}] \leq T_{\text{Discharge}}$, you should discharge to protect machine stopping;

4. Reducing frequency at high speed and power turn-off: If $[T_{\text{frequency reducing temperature at high speed during discharging}}] \leq T_{\text{Discharge}} < [T_{\text{Stop temperature during discharging}}]$ you should adjust the compressor frequency by reducing 30Hz/90s till the lower limit; After it was running 90s at the lower limit, if $[T_{\text{frequency reducing temperature at normal speed during discharging}}] \leq T_{\text{Discharge}}$, you should discharge to protect machine stopping;

5. Power turn-off: If the $[T_{\text{Power turn-off temperature during discharging}}] \leq T_{\text{Discharge}}$, you should discharge to protect machine stopping; If $T_{\text{Discharge}} < [T_{\text{Limited frequency temperature during discharging}}]$ and the compressor has been stopped for 3 minutes, the machine should be allowed to operate.

6. If the discharging temperature protection of compressor continuously occurs for six times, it should not be resumed automatically, and you should press the ON/OFF button to resume. During the process of running, if the running time of compressor exceeds the $[t_{\text{Protection times clearing of discharge}}]$, the discharge protection is cleared to recount. Stopped or transferred to supply air mode will clear the trouble times immediately (if the trouble cannot be resumed, mode transferring also will not clear it).

7. Frequency limited

If $[I_{\text{Limited frequency when overcurrent}}] \leq I_{\text{AC Electric current}} < [I_{\text{frequency reducing when overcurrent}}]$, you should limit the frequency raising of compressor.

8. Reducing frequency:

If $[I_{\text{Frequency reducing when overcurrent}}] \leq I_{\text{AC Electric current}} < [I_{\text{Power turn-off when overcurrent}}]$, you should reduce the compressor frequency till the lower limit or exit the frequency reducing condition;

9. Power turn-off: If $[I_{\text{Power turn-off machine when overcurrent}}] \leq I_{\text{AC Electric current}}$, you should carry out the over current stopping protection; If $I_{\text{AC Electric current}} < [I_{\text{Limited frequency when overcurrent}}]$ and the compressor has been stopped for 3 minutes, the machine should be allowed to operate.

10. If the overcurrent protection continuously occurs for six times, it should not be resumed automatically, and you should press the ON/OFF button to resume. During the process of running, if the running time of compressor exceeds the $[t_{\text{Protection times clearing of overcurrent}}]$, the discharge protection is cleared to recount.

(6) Voltage sag protection

After start the compressor, if the time of DC link Voltage sag $[U_{\text{Sagging protection voltage}}]$ is measured to be less than $[t_{\text{Voltage sag protection time}}]$, the machine should be stop at once, hand on the voltage sag trouble, reboot automatically after 30 minutes.

(7) Communication fault

When you have not received any correct signal from the inner machine in three minutes, the machine will stop for communication fault. When you have not received any correct signal from driver IC (aim to the controller for the separating of main control IC and driver IC), and the machine will stop for communication fault. If the communication is resumed, the machine will be allowed to operate.

Product Introduction

Basic Functions - 18K & 24K 230 volt

(8) Module protection

Testing the module protective signal immediately after started, once the module protective signal is measured, stop the machine with

module protection immediately. If the module protection is resumed, the machine will be allowed to operate.

If the module protection continuously occurs for three times, it should not be resumed automatically, and you should press the ON/OFF

button to resume. If the running time of compressor exceeds the [tProtection times clearing of module], the module protection is cleared to recount.

(9) Module overheating protection

1. Starting estimation:

After the compressor stopped working for 180s, if $T_{Module} < [T_{Module \text{ frequency limited temperature}}]$ (the temperature of hysteresis is 35.6°F), the

machine is allowed to start, otherwise it should not be started, and should be stopped to treat according to the module overheating

protection: The machine should be stopped or transferred to supply air, the trouble should be cleared immediately, and the protection times are not counted.

2. Frequency limited

If $[T_{\text{limited frequency temperature of module}}] \leq T_{Module} < [T_{\text{frequency reducing temperature at normal speed of module}}]$, you should limit the frequency raising of compressor.

3. Reducing frequency at normal speed and power turn-off: If $[T_{\text{frequency reducing temperature at normal speed of module}}] \leq T_{Module} <$

$[T_{\text{frequency reducing temperature at high speed of module}}]$, you should adjust the compressor frequency by reducing 8Hz/90s till the lower limit; After it was running 90s at the lower limit, if $[T_{\text{frequency reducing temperature at normal speed of module}}] < T_{Module}$, you should stop the machine for module overheating protection;

2. Frequency limited If $[T_{\text{limited frequency temperature of module}}] \leq T_{Module} < [T_{\text{frequency reducing temperature at normal speed of module}}]$, you should limit the frequency raising of compressor.

3. Reducing frequency at normal speed and power turn-off

If $[T_{\text{frequency reducing temperature at normal speed of module}}] \leq T_{Module} < [T_{\text{frequency reducing temperature at high speed of module}}]$, you should adjust the compressor

frequency by reducing 8Hz/90s till the lower limit; After it was running 90s at the lower limit, if $[T_{\text{frequency reducing temperature at normal speed of module}}] \leq T_{Module}$, you should stop the machine for module overheating protection;

4. Reducing frequency at high speed and power turn-off

If $[T_{\text{frequency reducing temperature at high speed of module}}] \leq T_{Module} < [T_{\text{Power turn-off temperature of module}}]$ you should adjust the compressor frequency by reducing 30Hz/90s till the lower limit; After it was running 90s at the lower limit, if $[T_{\text{frequency reducing temperature at normal speed of module}}] \leq T_{Module}$, you should stop the machine for module overheating protection;

5. Power turn-off

If the $[T_{\text{Power turn-off temperature of module}}] \leq T_{Module}$, you should stop the machine for module overheating protection; If $T_{Module} < [T_{\text{limited frequency temperature of module}}]$ and the compressor has been stopped for 3 minutes, the machine should be allowed to operate.

6. If protection continuously occurs for six times, it should not be resumed automatically, and you should press the ON/OFF button to resume. During the process of running, if the running time of compressor exceeds the [tProtection times clearing of module], the discharge protection is cleared to recount. Stopped or transferred to supply air mode will clear the trouble times immediately (if the trouble cannot be

Product Introduction

Basic Functions - 18K & 24K 230 volt

(10) Compressor overloads protection

If you measure the compressor overload switch action in 3s, the compressor should be stopped for overloading. The machine should be allowed to operate after overload protection was measured to resume.

If the overloading protection continuously occurs for three times, it should not be resumed automatically, and you should press the ON/OFF button to resume. The protection times of compressor is allowed to clear after the compressor run

[tProtection times clearing of compressor overloading]30 minutes.

(11) Phase current over current protection of compressor

During the running process of compressor, you could measure the phase current of the compressor, and control it according to the following steps:

1. Frequency limited

If $[I_{\text{Limited frequency phase current}}] \leq I_{\text{Phase current}} < [T_{\text{frequency reducing phase current}}]$, you should limit the frequency raising of compressor.

2. Reducing Frequency

If $[I_{\text{Frequency Reducing Phase Current}}] \leq I_{\text{Phase Current}} < [I_{\text{Power TurnOff Phase Current}}]$, the compressor shall continue to reduce frequency till the lowest frequency limit or out of the condition of reducing frequency;

3. Power turn-off If $I_{\text{Phase Current}} \geq [I_{\text{Power TurnOff Phase Current}}]$, the compressor phase current shall stop working for overcurrent protection; if

$I_{\text{Phase Current}} \leq [I_{\text{Frequency Reducing Phase Current}}]$, and the compressor have stopped working for 3 min, the machine shall be allowed to operate;

4. If the overcurrent protection of compressor phase current continuously occurs for six times, it should not be resumed automatically, and you should press the ON/OFF button to resume. During the process of running, if the running time of compressor exceeds the [tClearing Time of Compressor Phase Current Times], the overcurrent protection is cleared to recount.

(12) Starting-up Failure Protection for Compressor

Stop the compressor after its starting up fails, restart it after 20s if the fault doesn't shows, and if they are all failing for the successive start

3 times, it shall be reported as Starting up Failure, and then restart up it after 3 min. When it still not be able to operate through carry out

the above process for 5 times, it is available if press ON/OFF. And the compressor should be cleared the times after it run 2 min.

(13) Out-of-Step Protection for Compressor

The out of step protection signal should be detected immediately after starting up compressor, and once find the out-of-step protection signal,

the out of step protection shall be stopped; if it can run for lasting power turn off 3 min, the machine shall be allowed to operate. If it still

can't run automatically when the turn-off-times protection for compressor happens to stop working for 6 times in succession, it needs to

press ON/OFF to operate. And if the running time is more than 10 min, the power turn-off-times for out of step protection shall be cleared

and recounted.

Product Introduction

Basic Functions - 18K & 24K 230 volt

(14) Voltage Abnormality Protection for DC Bus To detect voltage abnormality protection for dc bus after completing the pre-charge:

1. Over-High Voltage Protection for DC Bus

If it found the DC bus voltage $UDC > [UDC \text{ Jiekuangchun Protection}]$, turn off PFC and stop the compressor at once, and it shall show the DC over-high voltage failure; it should clear out the failure when the voltage dropped to $UDC < [UDC \text{ Jiekuangchun Recovery}]$ and the compressor stopped for 3 min.

2. Over-Low Voltage Protection for DC Bus

If it found the DC bus voltage $UDC < [UDC \text{ Wantuochun Protection}]$, turn off PFC and stop the compressor at once, and it shall show the DC over-low voltage; and it should clear out the failure when the voltage raised to $UDC > [UDC \text{ Wantuochun Recovery}]$ and the compressor stopped for 3 min.

3. To detect voltage abnormality protect for DC bus when getting electricity

If it found the DC bus voltage $UDC > [UDC \text{---Over-High Voltage}]$, turn off the relay at once, and shows voltage abnormality failure for DC Bus. And the failure can't recover except to break off and get the electricity.

(15) Abnormity Protection for Four-way Valve

Under the model of heating operation in good condition: the compressor is detected TInner Tube < (TInner Ring - [TAbnormity Temperature Difference For Four-Way Valve Reversion]), during the running, it should be regarded as four-way valve reversion abnormality. And then it can run if stop the reversion abnormality protection for four-way valve 3 min; and if it still can't run when the reversion abnormality protection for four-way valve happens to stop working for 3 times in succession, it is available if presses ON/OFF.

Attention: the protection shall be shielded during the testing mode and defrosting process, and it shall be cleared out the failure and its times immediately when turning off or delivering wind / cooling / dehumidifying mode conversed (the inverted mode don't clear out the failure when it can't recover to operate).

(16) PFC Protection

1. After start up the PFC, it should detect the protection signal of PFC immediately; under the condition of PFC protection, it should turn off the PFC and compressor at one time;
2. It shows the failure is cleared out if PFC Protection stopped working 3 min and recovers to run automatically;
3. If it still can't run when it occurs PFC protection for 3 times in succession, it is available if presses ON/OFF; and clear the PFC Protection times when start up PFC for 10min.

Product Introduction

Basic Functions - 18K & 24K 230 volt

(17) Failure Detection for Sensor

1. Outdoor Ambient Sensor: detect the failure of sensor at all times.
2. Outdoor Tube Sensor: You should not detect the failure of outdoor tube sensor within 10 minutes heating operation compressor except the defrosting, and you could detect it at other time.
3. Outdoor Exhaust Sensor:
 - (a) The compressor only detect the sensor failure after it start up 3 min in normal mode; (b) It should detect the exhaust sensor failure immediately in the testing mode.
4. Module Temperature Sensor:
 - (a) Short-Circuit Detection: the compressor should be detected immediately when the module temperature sensor occurs short-circuits; (b) Open-Circuit Detection: the compressor should be detected on open-circuit when it runs 3min (it needn't 30s avoiding the module over-heated).
 - (c) Detect the sensor failure at all times in the testing mode.
5. Disposal for Sensor Protection
 - (1) When the short-circuit of sensor is detected within 30s, It is regarded as the temperature of sensor over-high (or infinitely high), and now according to the over-high sensor, the machine should carry out the corresponding protection to stop working, and show the corresponding temperature shutdown protection and sensor failure at the same time (for example: the compressor stops immediately when the outdoor tube sensor short-circuit, and the machine shall show the overload protection and outdoor tube sensor failure).
 - (2) When the open-circuit of sensor is detected within 30s, The protection shall be stopped and it shall show the corresponding sensor failure.

Product Introduction

Basic Functions - 30K & 36K 230 volt

1. Temperature Parameters

- Indoor preset temperature (T_{preset})
- Indoor ambient temperature (T_{amb})

2. Basic Functions

Once energized, in no case should the compressor be restarted within less than 3 minutes. In the situation that memory function is available, for the first energization, if the compressor is at stop before de-energization, the compressor will be started without a 3-minute lag; if the compressor is in operation before de-energization, the compressor will be started with a 3-minute lag; and once started, the compressor will not be stopped within 6 minutes regardless of changes in room temperature;

(1) Cooling Mode

a. Working conditions and process of cooling

When $T_{\text{amb}} > T_{\text{preset}}$, the unit will enter cooling operation, in which case the indoor fan, the outdoor fan and the compressor will work and the indoor fan will run at preset speed.

When $T_{\text{amb}} < T_{\text{preset}} - 3.6^{\circ}\text{F}$, the compressor will stop, the outdoor fan will stop with a time lag of 60s, and the indoor fan will run at preset speed.

When $T_{\text{preset}} - 3.6^{\circ}\text{F} < T_{\text{amb}} < T_{\text{preset}} + 1.8^{\circ}\text{F}$, the unit will remain at its previous state.

- Under this mode, the four-way valve will be de-energized and temperature can be set within a range from 61 to 86°F.

If the compressor is shut down for some reason, the indoor fan and the swing device will operate at original state.

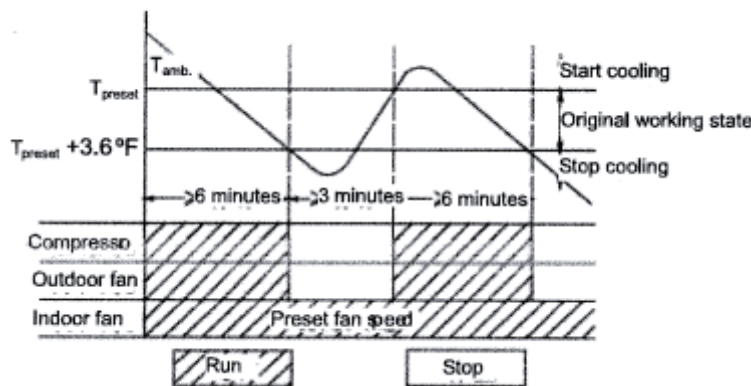

b. Protection

- Antifreeze protection

Under cooling and dehumidifying mode, 6 minutes after the compressor is started:

If $T_{\text{evap}} < 35.6^{\circ}\text{F}$, the compressor will operate at reduced frequency.

If $T_{\text{evap}} < 30.2^{\circ}\text{F}$ is detected for durative 3 minutes, the compressor will stop, and after 60 seconds, the outdoor fan will stop; and under cooling mode, the indoor fan and the swing motor will remain at the original state.

If $T_{\text{evap}} > 42.8^{\circ}\text{F}$ and the compressor has remained at OFF for at least 3 minutes, the compressor will resume its original operation state.

- Total current up and frequency down protection

If $I_{\text{total}} < 16\text{A}$, frequency rise will be allowed; if $I_{\text{total}} > 17\text{A}$, frequency rise will not be allowed; if $I_{\text{total}} > 18\text{A}$, the compressor will run at reduced frequency; and if $I_{\text{total}} > 20\text{A}$, the compressor will stop and the outdoor fan will stop with a time lag of 60s.

(2) Dehumidifying Mode

a. Working conditions and process of dehumidifying

If $T_{\text{amb}} > T_{\text{preset}} + 1.8^{\circ}\text{F}$, the unit will enter cooling and dehumidifying mode, in which case the compressor and the outdoor fan will operate and the indoor fan will run at low speed.

Product Introduction

Basic Functions - 30K & 36K 230 volt

If $T_{\text{preset}} - 3.6^{\circ}\text{F} < T_{\text{amb}} < T_{\text{preset}} + 1.8^{\circ}\text{F}$, the compressor remains at its original operation state.

If $T_{\text{amb}} < T_{\text{preset}} - 3.6^{\circ}\text{F}$, the compressor will stop, the outdoor fan will stop with a time lag of 60s, and the indoor fan will operate at low speed.

b. Protection

Protection is the same as that under the cooling mode.

(3) Heating Mode

a. Working conditions and the process of heating

If $T_{\text{amb}} < T_{\text{preset}} + 3.6^{\circ}\text{F}$, the unit enters heating mode, in which case the four-way valve, the compressor and the outdoor fan will operate simultaneously, and the indoor fan will run at preset speed in the condition of preset cold air prevention.

If $T_{\text{amb}} > T_{\text{preset}} + 9^{\circ}\text{F}$, the compressor will stop, the outdoor fan will stop with a time lag of 60s, and the indoor fan will stop after 60-second blow at low speed.

If $T_{\text{preset}} + 3.6^{\circ}\text{F} < T_{\text{amb}} < T_{\text{preset}} + 9^{\circ}\text{F}$, the unit will maintain its original operating status.

- Under this mode, the four-way valve is energized and temperature can be set within a range of 61-86F. The operating symbol, the heating symbol and preset temperature are revealed on the display.

b. Condition and process of defrost

When duration of successive heating operation is more than 45 minutes, or accumulated heating time more than 90 minutes, and one of the following conditions is reached, the unit will enter the defrost mode after 3 minutes.

A. $T_{\text{outdoor amb}} > 41^{\circ}\text{F}$, $T_{\text{outdoor pipe}} < 28.4^{\circ}\text{F}$

B. $28.4^{\circ}\text{F} < T_{\text{outdoor amb}}$

C. $23^{\circ}\text{F} < T_{\text{outdoor amb}} < 28.4^{\circ}\text{F}$, $T_{\text{outdoor pipe}} < 17.6^{\circ}\text{F}$

D. $14^{\circ}\text{F} < T_{\text{outdoor amb}} < 23^{\circ}\text{F}$, $T_{\text{outdoor pipe}} - T_{\text{compensation}} < (T_{\text{outdoor amb}} - 5.4^{\circ}\text{F})$

E. $T_{\text{outdoor amb}} < 14^{\circ}\text{F}$, $T_{\text{outdoor pipe}} - T_{\text{compensation}} < (T_{\text{outdoor amb}} - 5.4^{\circ}\text{F})$

F. $T_{\text{outdoor pipe}} > 35.6^{\circ}\text{F}$, $T_{\text{compensation}} = 0^{\circ}\text{F}$; b) $T_{\text{outdoor pipe}} < 35.6^{\circ}\text{F}$, $T_{\text{compensation}} = 5.4^{\circ}\text{F}$

At that time, the indoor fan stops and the compressor stops, and after 60 seconds the outer fan will stop, and then after 30 seconds, the four-way valve will stop. After 30 seconds, the compressor is initiated for raising the frequency to defrost frequency. When the compressor has operated under defrost mode for 10 minutes, or $T_{\text{outer tube}} > 50^{\circ}\text{F}$, the compressor will be converted to 46Hz operation. After 30 seconds, the compressor will stop. And after another 30 seconds, the four-way valve will be opened, and after 60 seconds, the compressor and the outer fan will be started, the indoor fan will run under preset cold air prevention conditions, and H1 will be displayed at temperature display area on the display panel. Defrost frequency is 70Hz.

c. Protection

- Cold air prevention

The unit is started under heating mode (the compressor is ON):

1. In the case of $T_{\text{indoor amb.}} < 75^{\circ}\text{F}$: if $T_{\text{tube}} < 104^{\circ}\text{F}$ and the indoor fan is at stop state, the indoor fan will begin to run at low speed with a time lag of 2 minutes. Within 2 minutes, if $T_{\text{tube}} > 104^{\circ}\text{F}$, the indoor fan also will run at low speed; and after 1-minute operation at low speed, the indoor fan will be converted to operation at preset speed. Within 1-minute low speed operation or 2-minute non-operation, if $T_{\text{tube}} > 108^{\circ}\text{F}$, the fan will run at present speed.

Product Introduction

Basic Functions - 30K & 36K 230 volt

2. In the case of $T_{\text{indoor amb}} < 75^{\circ}\text{F}$: if $T_{\text{tube}} < 108^{\circ}\text{F}$, the indoor fan will run at low speed, and after one minute, the indoor fan will be converted to preset speed. Within one-minute low speed operation, if $T_{\text{tube}} > 104^{\circ}\text{F}$, the indoor fan will be converted to preset speed.

Note: $T_{\text{indoor amb}}$ indicated in \boxtimes and \boxtimes refers to, under initially heating mode, the indoor ambient temperature before the command to start the compressor is performed according to the program, or after the unit is withdrawn from defrost, the indoor ambient temperature before the defrost symbol is cleared.

- Total current up and frequency down protection

If the total current $I_{\text{total}} < 16\text{A}$, frequency rise will be allowed; if $I_{\text{total}} > 17\text{A}$, frequency rise will not be allowed; if $I_{\text{total}} > 18\text{A}$, the compressor will run at reduced frequency; and if $I_{\text{total}} > 20\text{A}$, the compressor will stop and the outdoor fan will stop with a time lag of 60s.

(4) Fan mode

Under the mode, the indoor fan will run at preset speed and the compressor, the outdoor fan, the four-way valve and the electric heater will stop.

- Under the mode, temperature can be set within a range of $61\text{-}86^{\circ}\text{F}$.

(5) AUTO Mode

A. Working conditions and process of AUTO mode

Under AUTO mode, standard cooling temperature T_{preset} is 77°F and standard heating temperature T_{preset} is 68°F .

a. Once energized, if $T_{\text{amb}} < 71.6^{\circ}\text{F}$, the unit will be started under heating mode; if $71.6^{\circ}\text{F} < T_{\text{amb}} < 78.8^{\circ}\text{F}$, the unit will run under fan mode and the run indicator will be bright; and if $T_{\text{amb}} > 78.8^{\circ}\text{F}$, the unit will be started under cooling mode.

b. Under AUTO mode, if $T_{\text{amb}} > T_{\text{preset}} + 1.8^{\circ}\text{F}$ is detected, the unit will select to run under cooling mode, in which case implicit preset temperature is 77°F ; if $T_{\text{amb}} < T_{\text{preset}} - 1.8^{\circ}\text{F}$, the compressor will stop, the outdoor fan will stop with a time lag of 1 minute, and the indoor fan will run at preset speed; and if $T_{\text{preset}} - 1.8^{\circ}\text{F} < T_{\text{amb}} < T_{\text{preset}} + 1.8^{\circ}\text{F}$, the unit will remain at its original state.

c. Under AUTO mode, if $T_{\text{amb}} < T_{\text{preset}} + 3.6^{\circ}\text{F}$ is detected, the unit will select to run under heating mode, in which case implicit preset temperature is 64°F ; if $T_{\text{amb}} > T_{\text{preset}} + 9^{\circ}\text{F}$, the compressor will stop, the outdoor fan will stop with a time lag of 1 minute, and the indoor fan will run under the mode of residue heating blowing; and if $T_{\text{preset}} + 3.6^{\circ}\text{F} < T_{\text{amb}} < T_{\text{preset}} + 41^{\circ}\text{F}$, the unit will remain at its original state. The cooling-only unit will run under fan mode.

d. Under AUTO mode, if $71.6^{\circ}\text{F} < T_{\text{amb}} < 78.8^{\circ}\text{F}$, the unit will remain at its original state

B. Protection

a. In cooling operation, protection is the same as that under the cooling mode;

b. In heating operation, protection is the same as that under the heating mode;

c. When ambient temperature changes, operation mode will be converted preferentially. Once started, the compressor will remain unchanged for at least 6 minutes.

Product Introduction

Basic Functions - 30K & 36K 230 volt

(6) Common Protection Functions and Fault Display under COOL, HEAT, DRY and AUTO Modes

A. Overload protection

Ttube: measured temperature of outdoor heat exchanger under cooling mode; and measure temperature of indoor heat exchanger under heating mode.

1) Cooling overload

- a. If Ttube < 126°F, the unit will return to its original operation state.
- b. If Ttube > 131°F, the frequency rise is not allowed.
- c. If Ttube > 136°F, the compressor will run at reduced frequency.
- d. If Ttube > 144°F, the compressor will stop and the indoor fan will run at preset speed.

2) Heating overload

- a. If Ttube < 126°F, the unit will return to its original operation state.
- b. If Ttube > 131°F, the frequency rise is not allowed.
- c. If Ttube > 136°F, the compressor will run at reduced frequency.
- d. If Ttube > 144°F, the compressor will stop and the indoor fan will run at preset speed.

B. Exhaust temperature protection of compressor

If exhaust temperature > 208°F, frequency is not allowed to rise.

If exhaust temperature > 217°F, the compressor will run at reduced frequency.

If exhaust temperature > 230°F, the compressor will stop.

If exhaust temperature < 194°F and the compressor has stayed at stop for at least 3 minutes, the compressor will resume its operation.

C. Communication fault

If the unit fails to receive correct signals for durative 3 minutes, communication fault can be justified and the whole system will stop

D. Module protection

Under module protection mode, the compressor will stop. When the compressor remains at stop for at least 3 minutes, the compressor will resume its operation. If module protection occurs six times in succession, the compressor will not be started again.

E. Overload protection

If temperature sensed by the overload sensor is over 239°F, the compressor will stop and the outdoor fan will stop with a time lag of 30 seconds. If temperature is below 203°F, the overload protection will be relieved.

If voltage on the DC bus is below 150V or over 420V, the compressor will stop and the outdoor fan will stop with a time lag of 30 seconds. When voltage on the DC bus returns to its normal value and the compressor has stayed at stop for at least 3 minutes, the compressor will resume its operation.

F. Fault of temperature sensors

Product Introduction

Basic Functions - 30K & 36K 230 volt

Designation of Sensors	Faults
Indoor Ambient Temperature	The sensor is detected to be open-circuited or short-circuited for successive 30 seconds
Indoor Tube Temperature	The sensor is detected to be open-circuited or short-circuited for successive 30 seconds
Outdoor Ambient Temperature	The sensor is detected to be open-circuited or short-circuited for successive 30 seconds
Outdoor Tube Temperature	The sensor is detected to be open-circuited or short-circuited for successive 30 seconds, and no detection is preformed within 10 minutes after defrost begins.
Exhaust	After the compressor has operated for 3 minutes, the sensor is detected to be open-circuited or short circuited for successive 30 seconds.
Overload	After the compressor has operated for 3 minutes, the sensor is detected to be open-circuited or short circuited for successive 30 seconds.

Remote Control Operation

Remote Buttons

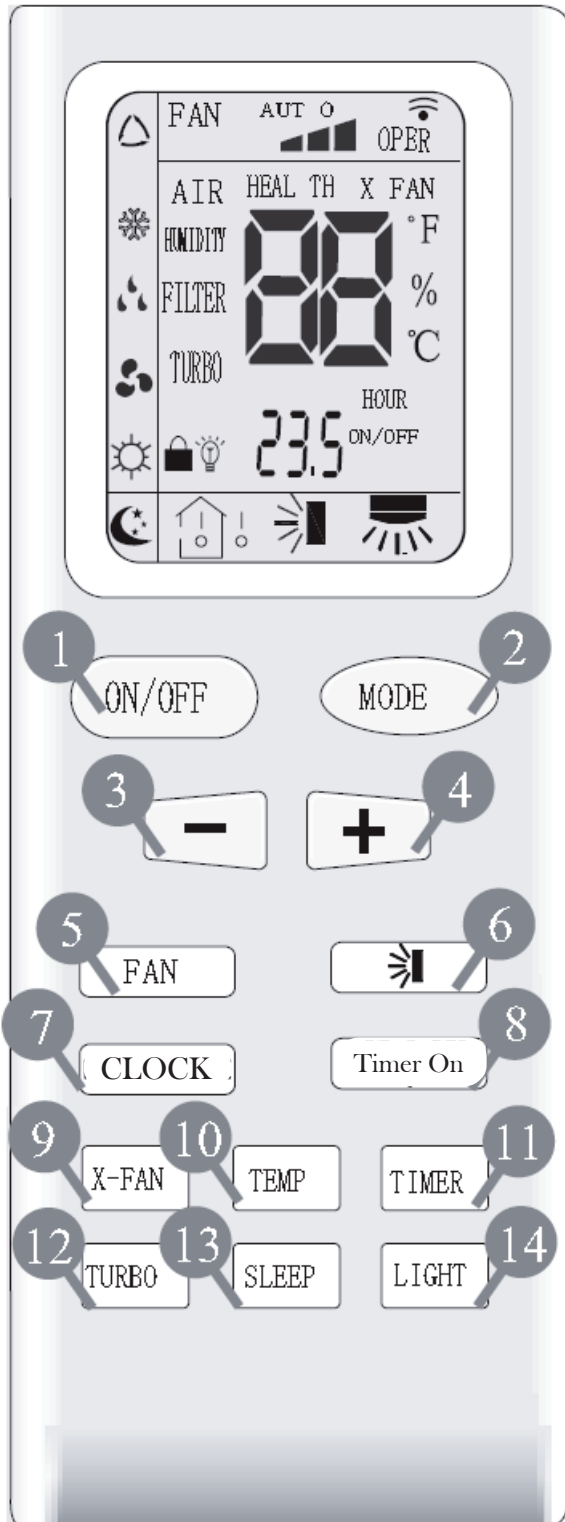

Note:

This remote control is used in other models and some features may or may not be available. Consult the owners manual for specific features for your model. There should be no obstructions between the remote control and the indoor unit for proper operation. Keep the remote from direct sunlight or any source that generates heat, keep clean and dry. Change batteries frequently.

Note:

For detailed explanation of the functions, refer to the “Remote Controller Functions” section of this manual.

Button Identification

The function and operation of each button will be explained later in this manual under Product Functions.

1. On/Off button
2. Mode button
3. Decrease Temperature Setting
4. Increase Temperature Setting
5. Fan Button
6. Press to set swing angle
7. Clock Button
8. Timer On
9. X-Fan button, see explanation below
10. Temp button
11. Timer
12. Turbo button
13. Sleep button
14. Light Button

See explanations next page.

Press Mode & “-” button to change from C to F

Press “-” & “+” to lock control

Remote Control Operation

Display Icons

- 15. Mode Icon
- 16. Lock Icon
- 17. Light Icon
- 18. Sleep Icon
- 19. Temp Icon
- 20. Up & Down Swing Icon
- 21. Left & Right Swing Icon
- 22. Set Time Display
- 23. Digit Display
- 24. Fan Speed Display

See explanations next page.

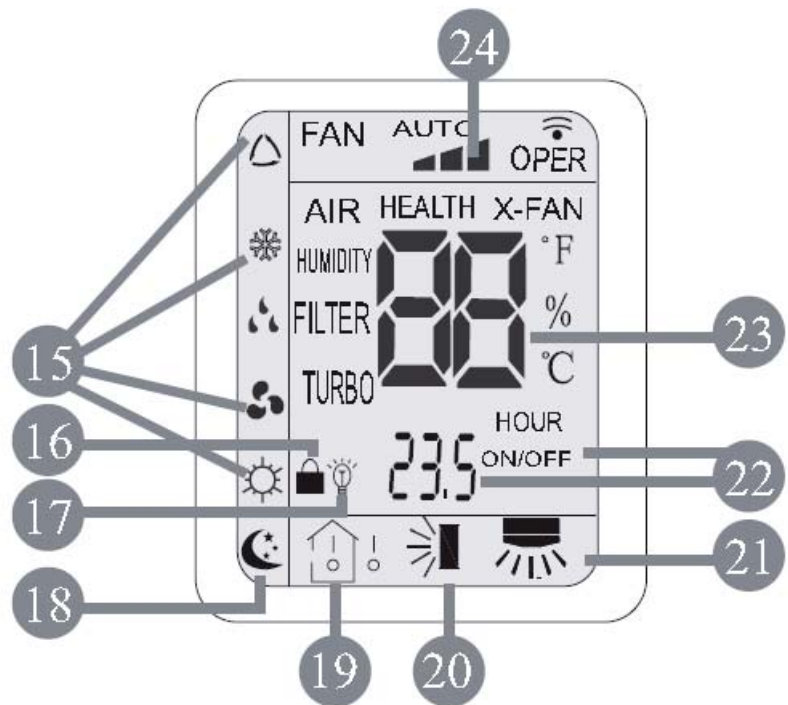

Replacing Batteries:

1. Locate the battery cover on the back of the remote.
2. Remove the small screw at the bottom of the cover.
3. Slide the cover downward.
4. Replace with two “AAA” batteries.
5. Replace cover and screw.



Product Introduction

Remote Controller Functions

1) On/Off

Press this button to turn unit on or off

2) Mode

Press the “Mode” button to change from Auto, Cool, Dry, Fan or Heat Pump

3) Lower Temperature Setting

Each time you press the “-” button the temperature setting will lower by 1° F. Hold button down for 2 seconds to rapidly decrease setting. The temperature range is 61° F - 86° F. In Auto Mode this button will not function.

4) Raise Temperature Setting

Each time you press the “+” button the temperature setting will raise by 1° F. Hold button down for 2 seconds to rapidly increase setting. The temperature range is 61° F - 86° F. In Auto Mode this button will not function.

5) Fan Switch

The fan switch will adjust the fan speed between Auto, Low, Medium and High.

6) Swing Button

Press this button to stop or start the up/down swing function. Press the “+” and Swing button together will switch between static and simple swing.

7) Clock Button

Press this button to set clock. Press “_” or “+” within 5 seconds to change time. Holding buttons down for more than 2 seconds will speed up time. Press Clock again to save setting.

8) Timer On

Press this button to initiate the Auto-On timer. Press this button again to disable the function. Within 5 seconds press the + or - buttons to adjust the time value. Holding down the buttons will change time at a faster pace.

9) X-Fan

Pressing X-Fan button in Cool mode will allow indoor fan to run for 10 minutes after the cooling cycle has stopped. This will dry off indoor coil.

10) Temp Button

This button will change the indoor display from reading indoor ambient or the indoor set temperature

11) Timer Off Button

This button performs same as Timer On button.

Product Introduction

Remote Controller Functions

12) Turbo Button

Press this button to enable the Turbo function. This will increase the fan speed to achieve room set temperature in the shortest amount of time.

13) Sleep Button

Sets sleep mode function, see owners manual for specific model information

14) Light Button

Press this button to turn on or off the display light.

Display Icons

15) Mode Icon

Indicates current mode of unit

16) Lock Icon

Indicates if control is locked.

17) Light Icon

Indicates lights is on.

18) Sleep Icon

Indicates if sleep mode is on.

19) Temp Icon

Indicates if display is indicating indoor ambient or set temperature.

20) Up/Down Swing Icon

Indicates if indoor unit is in up & down swing function

21) Left/Right Swing Icon (Not on all models)

Indicates if indoor unit is in left & right swing function

22) Set Time Display

After pressing the timer button, this will display the set time.

Product Introduction

Remote Controller Functions

23) Digital Display

This area will show the set temperature. In save mode, “SE” will be displayed.

24) Fan Speed Display

The fan speed will be displayed in this area, except the “Auto” mode

Auto Button (Manual Override) - *Located on indoor unit.*

In the event the controller is missed placed or the batteries are defective, this will override the remote controller. If the controller is on, pressing this button will stop it, if it is off, pressing the button will turn the controller on. When turning the controller on, the swing and light will be on and the unit will run in Auto Mode.



Refrigerant Lines Connection, Evacuating and Charging

Refrigerant Lines Preparation & Connection

The refrigerant lines should be kept sealed until ready to be connected. Follow the following steps to insure a quality leak proof installation:

Step 1. Refrigerant Line Connection

Carefully bend and cut the tubing to prepare for flaring. Use a flaring tool designed for R410a, following the recommended manufacturer's procedure. Tighten the flare nut to the indicated torque by using a spanner wrench and a torque wrench. Connect the indoor unit first, then the outdoor unit. Use the 3/8" to 1/2" flare adapter if needed.

Note:

Over tightening flare nuts may damage flare connections and may cause leaks.

Tubing Size	Torque (foot-pounds)	Torque (inch-pounds)
1/4"	10-13	124-159
3/8"	25-31	301-372
1/2"	36-45	434-540
5/8"	50-60	602-726

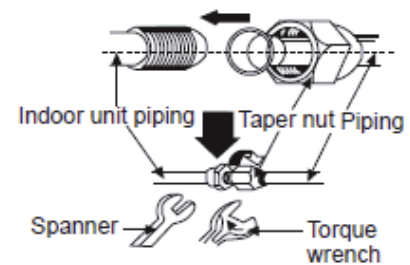
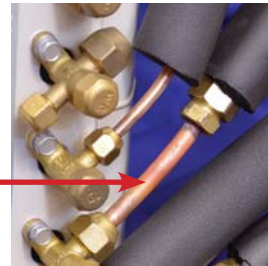

Step 2. System Leak Check

Refrigerant lines should be pressurized prior to evacuating system to check for leaks.

Use only dry nitrogen with a pressure regulator for pressurizing unit. Pressurize with 150 psi of dry nitrogen. Apply soap and water to check whether the joints are leaky. A leak detector may also be used for a leakage test.

Hint:

You may want to perform leak testing and evacuation before wiring to save time, electrical connections can be completed while your vacuum pump is running.



Step 3. System Evacuation

Note: The outdoor unit contains a refrigerant charge, leave liquid and gas valves closed.

1. After no leaks have been detected, connect a vacuum pump to the outdoor unit.
2. Connect appropriate hoses to manifold gauge, vacuum pump and unit refrigeration connections.
3. Evacuate the system until the micron gauge reads no higher than 350 microns.
4. Close valve to vacuum pump; if pressure does not rise above 500 microns after one minute, the evacuation should be complete.
5. If it does rise, check for leaks and/or evacuate longer.
6. For refrigerant lines longer than 25 feet, refer to installation instructions chart included with the unit installation manual for additional charge.



Refrigerant Charging Procedure

Please refer to your units installation manual for proper charge. If your lineset exceeds the chart below for your model, additional charge may be required. The charge must be weighed in with a refrigerant charging scale.

You can only add additional refrigerant to a new installation. If a low or high charge is suspected, you must reclaim the refrigerant, then weigh in the correct amount per specifications including any additional for long linesets. It is important to check for leaks before adding refrigerant.

1. Determine additional refrigerant charge.

The Neo single zone units contain a factory charge adequate for up to a total length of refrigerant line as indicated in the chart below. Additional refrigerant will need to be added for total lengths over the listed length. Confirm the following chart with your installation manual for additional charge amounts:

	NEO09HP-115V1AS	NEO12HP-115V1AS	NEO09HP-230V1AS	NEO12HP-230V1AS
Additional Charge	0.22 oz./ft.	0.22 oz./ft.	0.22 oz./ft.	0.22 oz./ft.
Max Length without Additional Charge	25 ft.	25 ft.	25 ft.	25 ft.
Factory Charge	42 oz.	45.5 oz.	46 oz.	46 oz.
Max. Total Piping Length	66 ft.	66 ft.	50 ft.	66 ft.
Max. Elevation	33 ft.	33 ft.	33 ft.	33 ft.
	NEO18HP-230V1AS	NEO24HP-230V1AS	NEO30HP-230V1AS	NEO36HP-230V1AS
Additional Charge	0.22 oz./ft.	0.5 oz./ft.	0.5 oz./ft.	0.5 oz./ft.
Max Length without Additional Charge	25 ft.	25 ft.	25 ft.	25 ft.
Factory Charge	49 oz.	56 oz.	84.7 oz.	91.7 oz.
Max. Total Piping Length	82 ft.	82 ft.	100	100
Max. Elevation	33 ft.	33 ft.	33 ft.	33 ft.

Refrigerant Charging Procedure

2. Leak Testing

Follow the procedures for leak testing with nitrogen prior to adding charge on a new installation or existing one suspected for leaks. See preceding page.



3. Attach hoses to the unit and vacuum pump

5/16" x 1/4" adapter may be required to connect hose to port.

Check to insure that the liquid and gas valves are closed on the unit. Close all valves on your gauge set, then connect the vacuum pump to your gauge set. Pump down lineset and indoor unit.



4. Zero charging scale

Place the refrigerant tank on the charging scale. Open the tank valve, turn on the scale, then zero the scale.



Refrigerant Charging Procedure, cont.

5. Begin adding additional refrigerant

Charging should be completed with the unit off (not running) and through the liquid side with liquid refrigerant. If there are no ports on the liquid side, use the gas side port connection, charging with liquid.

Record the amount of additional charge for future reference.



6. Charge to the correct weight

If the scale was zeroed with the refrigerant tank on the scale, the amount added to the system will be a negative amount since it was removed from the tank. After the proper amount of refrigerant has been weighed in, close the manifold valve.



7. Remove refrigerant tank

Close the tank valve, then carefully remove the hose and adapter. Replace the charging port cap back on the outdoor unit valves. On new installations, open all liquid and vapor service valves.



Installation

Proper installation site is vital for correct and efficient operation of the unit. Avoid the following sites where:

- Strong heat sources, vapors, flammable gas or volatile liquids are emitted.
- High-frequency electro-magnetic waves are generated by radio equipment, welders and medical equipment.
- The air is contaminated with industrial vapors and oils.
- The air contains sulfurous gas such as in hot spring zones.
- Poor air quality exists.

Indoor Unit



The air inlet and outlet should be away from any obstructions. Ensure the air will easily circulate through the entire room.

1. Select a site where the condensate can be easily routed or consider a condensate removal pump.
2. Select a place where it is out of reach of children.
3. Select a place that has adequate mounting structure, strong enough to withstand the full weight and vibration of the unit.
4. Be sure to leave enough space to allow access for routine maintenance. Refer to unit installation specifications for clearances. Select a place more than 3 feet away from any TV or other electrical appliances

Outdoor Unit



1. Select a suitable site where proper drainage will occur.
2. Select a site where there is sufficient ventilation.
3. Select a site where there is no obstruction blocking the inlet and outlet.
4. The site should be able to withstand the full weight of the unit.
5. Try to limit expose to direct sunlight or strong winds.
6. Make sure that the outdoor unit is installed in accordance with the installations instructions, and is convenient for maintenance and repair.
7. Refer to your outdoor unit installation manual for maximum lineset lengths and heights. This could be a factor in determining outdoor location.
8. Select a place where it is out of reach of children.
9. Install Heat Pump legs to allow for proper drainage.
10. Install drain fitting in bottom of outdoor unit



Installation

Mounting Plate Installation



1. The mounting plate should be installed horizontally and level.
2. Measure the center of the indoor unit. Please note, that depending on model, the center of the bracket may not correspond with the center of the unit.
3. Attach the mounting plate on the wall with screws.
4. Be sure that the mounting plate has been attached firmly enough to withstand approximately 132 pounds.
5. Refer to specific models for dimensional data.

Locate and Drill Hole



1. The piping can exit the indoor unit from either side, see pictured below.
2. Drill a 2-1/2" diameter hole at a slightly downward angle to the outdoor side.
3. Note: The outdoor hole should be approximately 1/4" lower than the indoor hole.
4. Insert the piping-hole sleeve into the hole to prevent the piping and wiring from being damaged when passing through the hole.

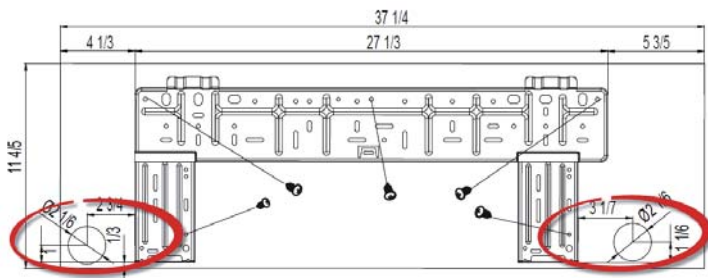

Installation

Install Drain Hose

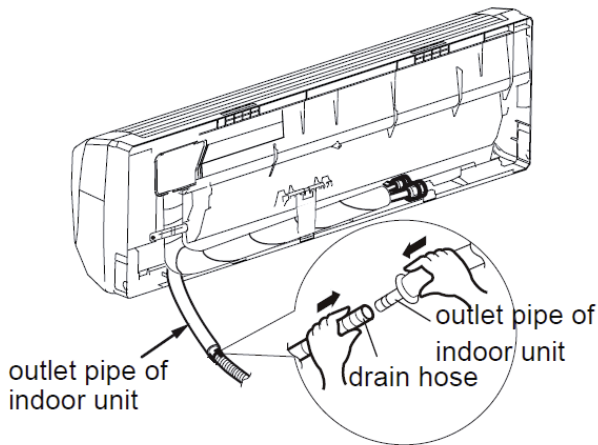

1. Connect the drain hose to the outlet pipe of the indoor unit using appropriate connections.
2. Insulate the condensate to prevent condensation.
3. Fasten the condensate, lineset and wiring together to prevent damage and movement. Slant the drain hose downward for smooth drainage.

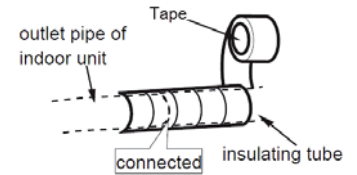
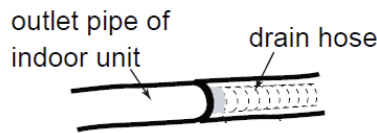

Install Line Set



1. Install lineset and wiring from the outside through the wall sleeve.
2. Bend the indoor lineset. Note: a tube bender will speed up the process.
3. Carefully remove flare nut from indoor coil. Listen for holding charge from indoor unit. No charge may indicate a leak and should be tested.
4. Use a flaring tool if necessary to create the flare, connect tubing tightening to the torque listed below.

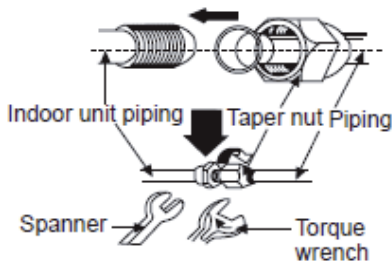

Tubing Size	Torque (foot-pounds)	Torque (inch-pounds)
1/4"	10-13	124-159
3/8"	25-31	301-372
1/2"	36-45	434-540
5/8"	50-60	602-726



Installation

Pressure and Leak Test



1. Use only dry nitrogen with a pressure regulator for pressurizing unit. Pressurize with 150 psi of dry nitrogen.
2. Apply soap and water to check whether the joints are leaky. A leak detector can also be applied for a leakage test.

Hint: You may want to perform leak testing and evacuation before wiring to save time, electrical connections can be completed while your vacuum pump is running.

Evacuating the System



Note: The outdoor unit contains a refrigerant charge, leave liquid and gas valves closed.

1. After no leaks have been detected, connect a vacuum pump to the outdoor unit.
2. Connect appropriate hoses to manifold gauge, vacuum pump and unit refrigeration connections.
3. Evacuate the system until the micron gauge reads no higher than 350 microns.
4. Close valve to vacuum pump; if pressure does not rise above 500 microns after one minute, the evacuation should be complete.
5. If it does rise, check for leaks and/or evacuate longer.
6. For refrigerant lines longer than 25 feet, refer to installation instructions chart included with the unit installation manual for additional charge.

Installation

Connect the Outdoor Wiring

Note:

Confirm proper voltage before connecting wires.

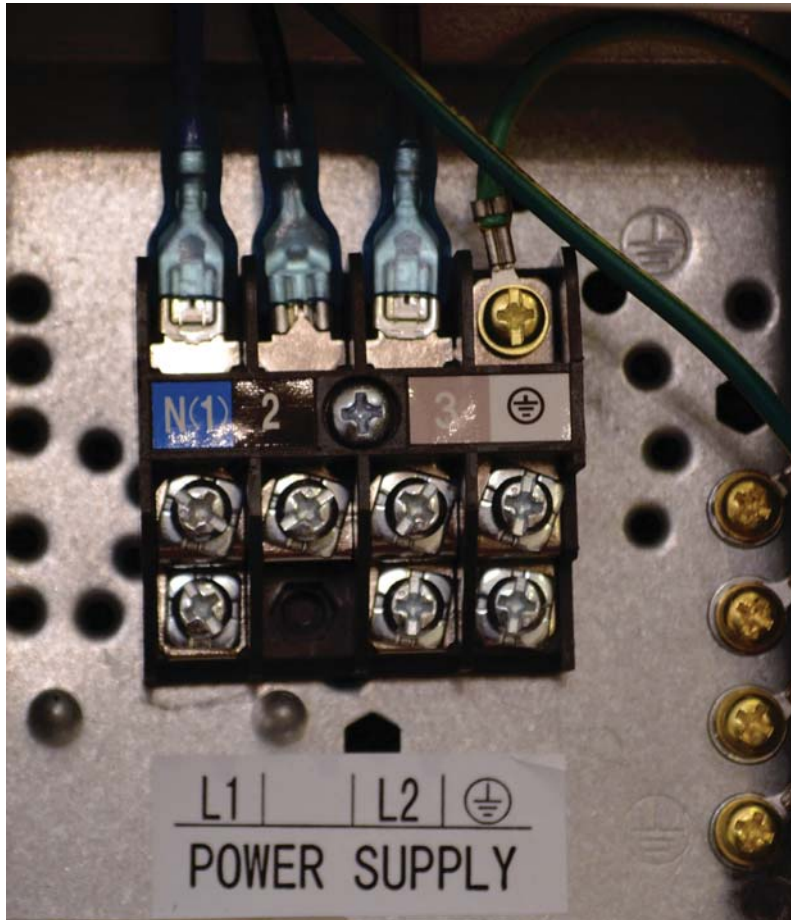

1. Remove the handle on the right side plate of the outdoor unit.
2. Connect wiring from indoor unit to 1,2,3 & ground, being careful to match color code of indoor connections. Repeat this for each indoor unit.
3. Connect power wiring from outdoor disconnect to L1, L2 and ground.
4. Check all connections to tightness.
5. Reinstall the cover/handle.

Note: Follow all local electrical codes for electrical wiring.

Filter Maintenance and Emergency Operation

Cleaning Air Filter

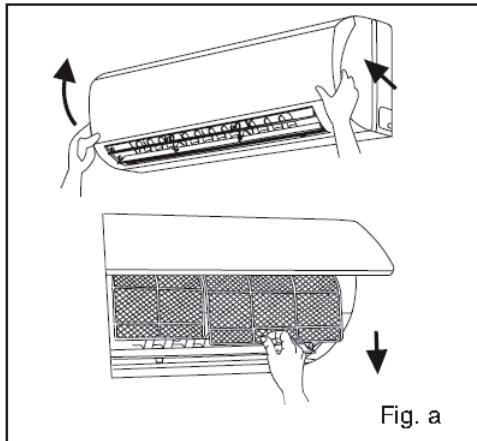

1. Lift up the front panel to access the air filter. Fig A
2. The first stage filter can be cleaned with a vacuum cleaner or by washing with a mild soap and $< 113^{\circ}$ F water. Fig B
3. Replace dry filter into indoor unit as shown in Fig C.

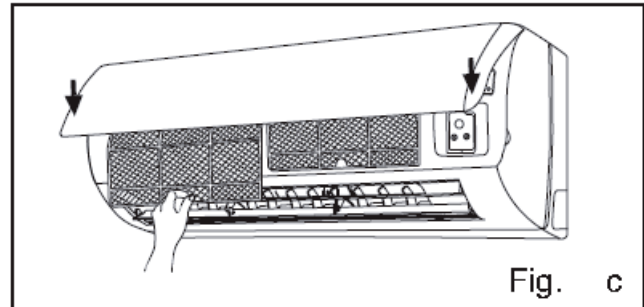
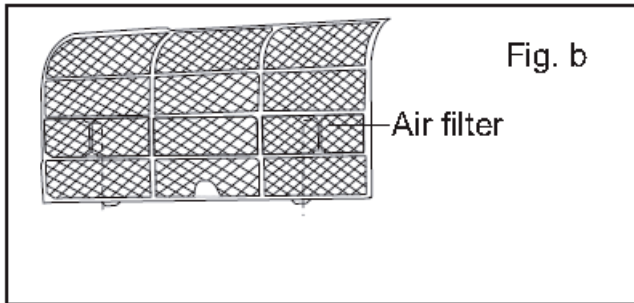

Missing or Inoperative Remote Control



Emergency Operation:

When the remote controller is lost or damaged, please use the auto switch on the indoor unit.

Press the AUTO/STOP button to enter AUTO mode.

Press the AUTO/STOP button again to turn the unit off.

Electrical Schematics

NEO09HP115V1AH

NEO09HP115V1AH 115 vac

Symbol	Color Symbol	Symbol	Color Symbol
OG	Orange		Earth Ground
WH	White	COMP.	Compressor
YE	Yellow	CT1,2	Overload
RD	Red	4V	4-Way Valve
YEGN	Yellow-Green	XT	Terminal Block
BN	Brown	Vt	Violet
BU	Blue		
BK	Black		

Indoor Board

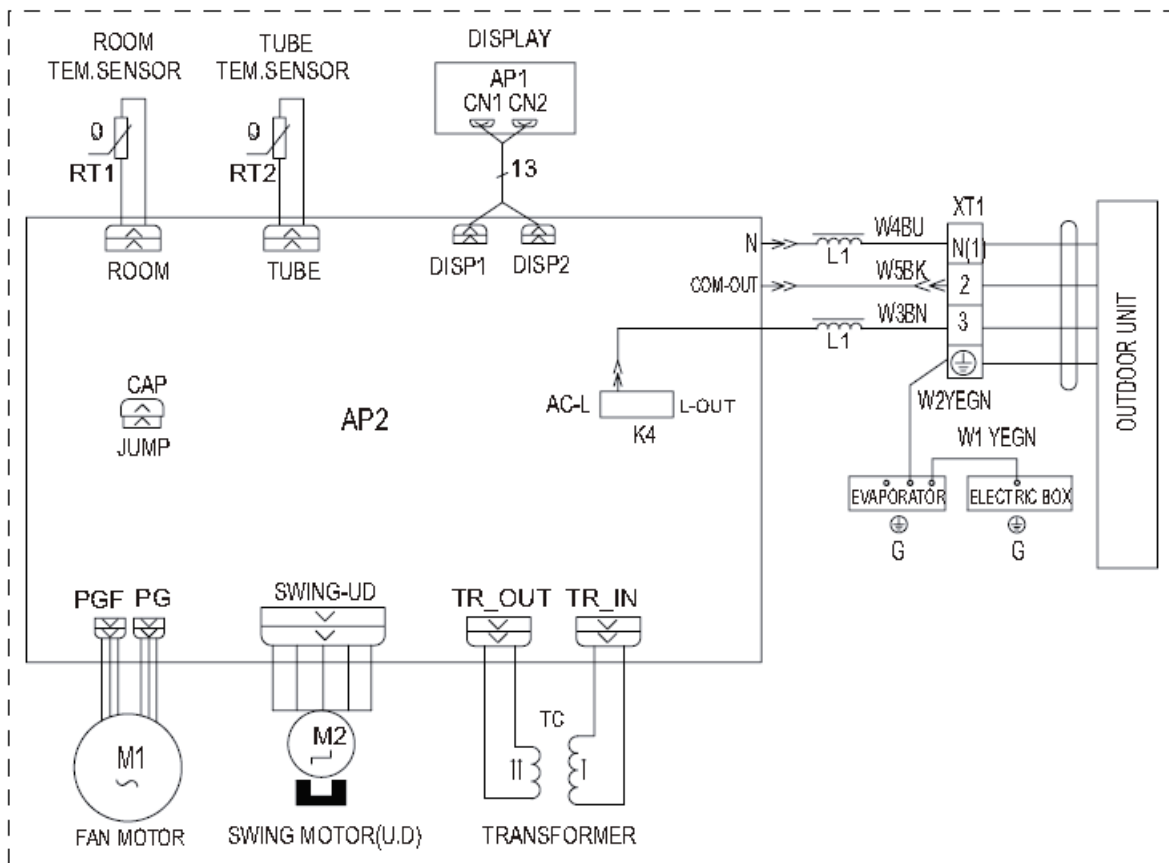

Circuit diagrams are subject to change without notice, please refer to the one supplied with the unit.

Electrical Schematics

NEO09HP115V1AO

NEO09HP115V1AO 115 vac

Symbol	Color Symbol	Symbol	Color Symbol
OG	Orange		Earth Ground
WH	White	COMP.	Compressor
YE	Yellow	CT1,2	Overload
RD	Red	4V	4-Way Valve
YEGN	Yellow-Green	XT	Terminal Block
BN	Brown	VT	Violet
BU	Blue		
BK	Black		

Outdoor Unit

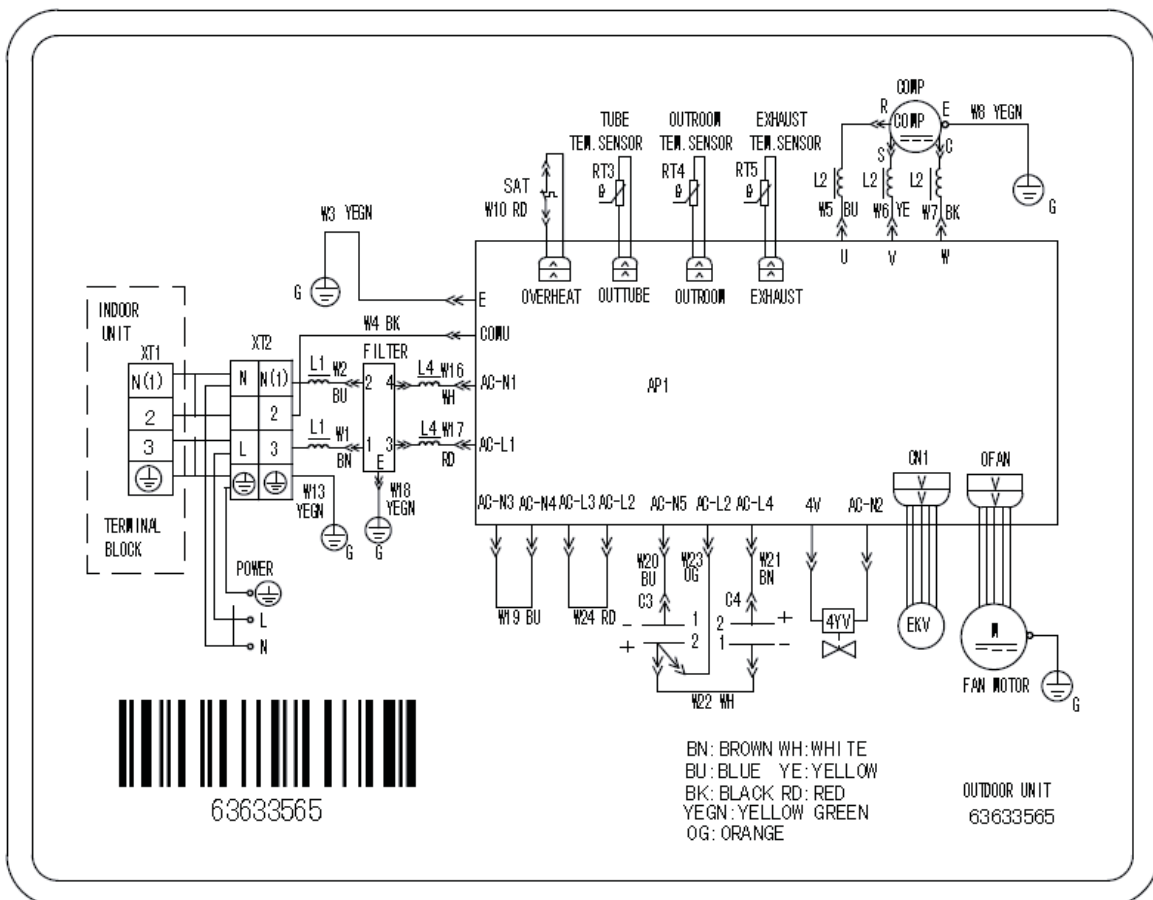

Circuit diagrams are subject to change without notice, please refer to the one supplied with the unit.

Electrical Schematics

NEO09HP230V1AH

Indoor Board

NEO09HP230V1AH 240vac

Symbol	Color Symbol	Symbol	Color Symbol
OG	Orange		Earth Ground
WH	White	COMP.	Compressor
YE	Yellow	CT1,2	Overload
RD	Red	4V	4-Way Valve
YEGN	Yellow-Green	XT	Terminal Block
BN	Brown	VT	Violet
BU	Blue		
BK	Black		

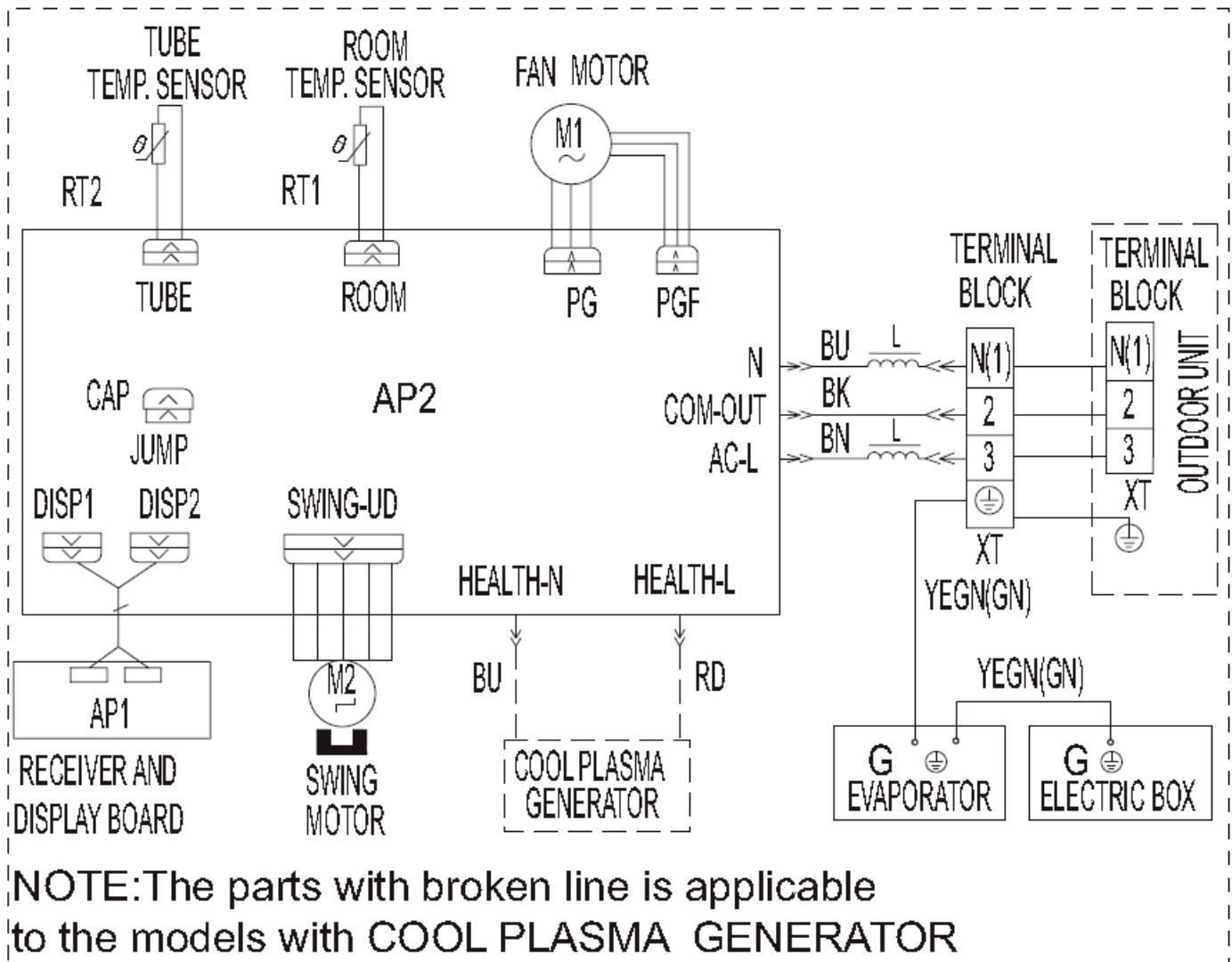

Circuit diagrams are subject to change without notice, please refer to the one supplied with the unit.

Electrical Schematics

NEO09HP230V1AO

Outdoor Board

NEO09HP230V1AO 240vac

Symbol	Color Symbol	Symbol	Color Symbol
OG	Orange		Earth Ground
WH	White	COMP.	Compressor
YE	Yellow	CT1,2	Overload
RD	Red	4V	4-Way Valve
YEGN	Yellow-Green	XT	Terminal Block
BN	Brown	VT	Violet
BU	Blue		
BK	Black		

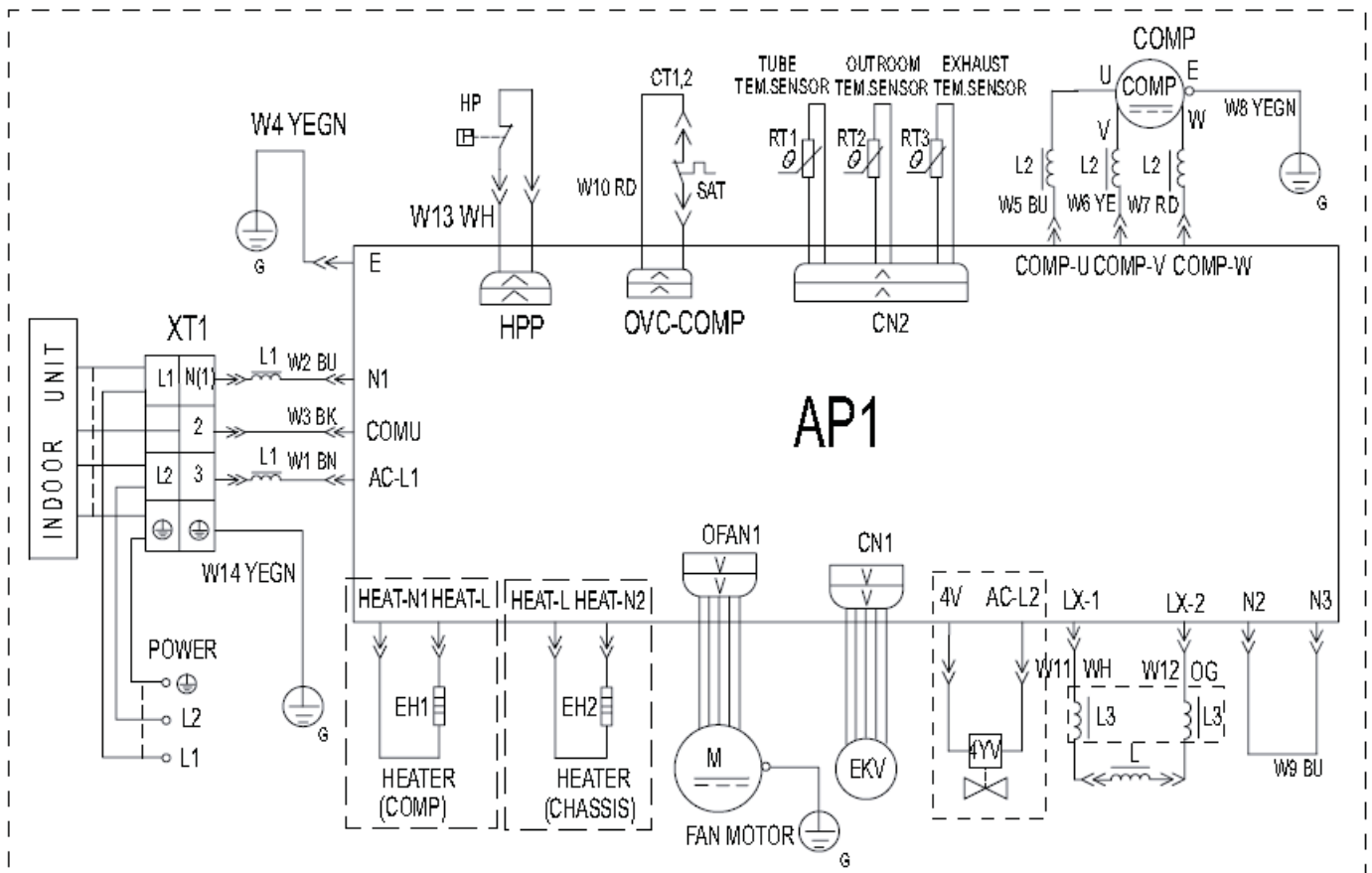

Circuit diagrams are subject to change without notice, please refer to the one supplied with the unit.

Electrical Schematics

NEO18HP230V1AH 230v

Indoor Board

Symbol	Color Symbol	Symbol	Color Symbol
OG	Orange		Earth Ground
WH	White	COMP.	Compressor
YE	Yellow	CT1,2	Overload
RD	Red	4V	4-Way Valve
YEGN	Yellow-Green	XT	Terminal Block
BN	Brown	VT	Violet
BU	Blue		
BK	Black		

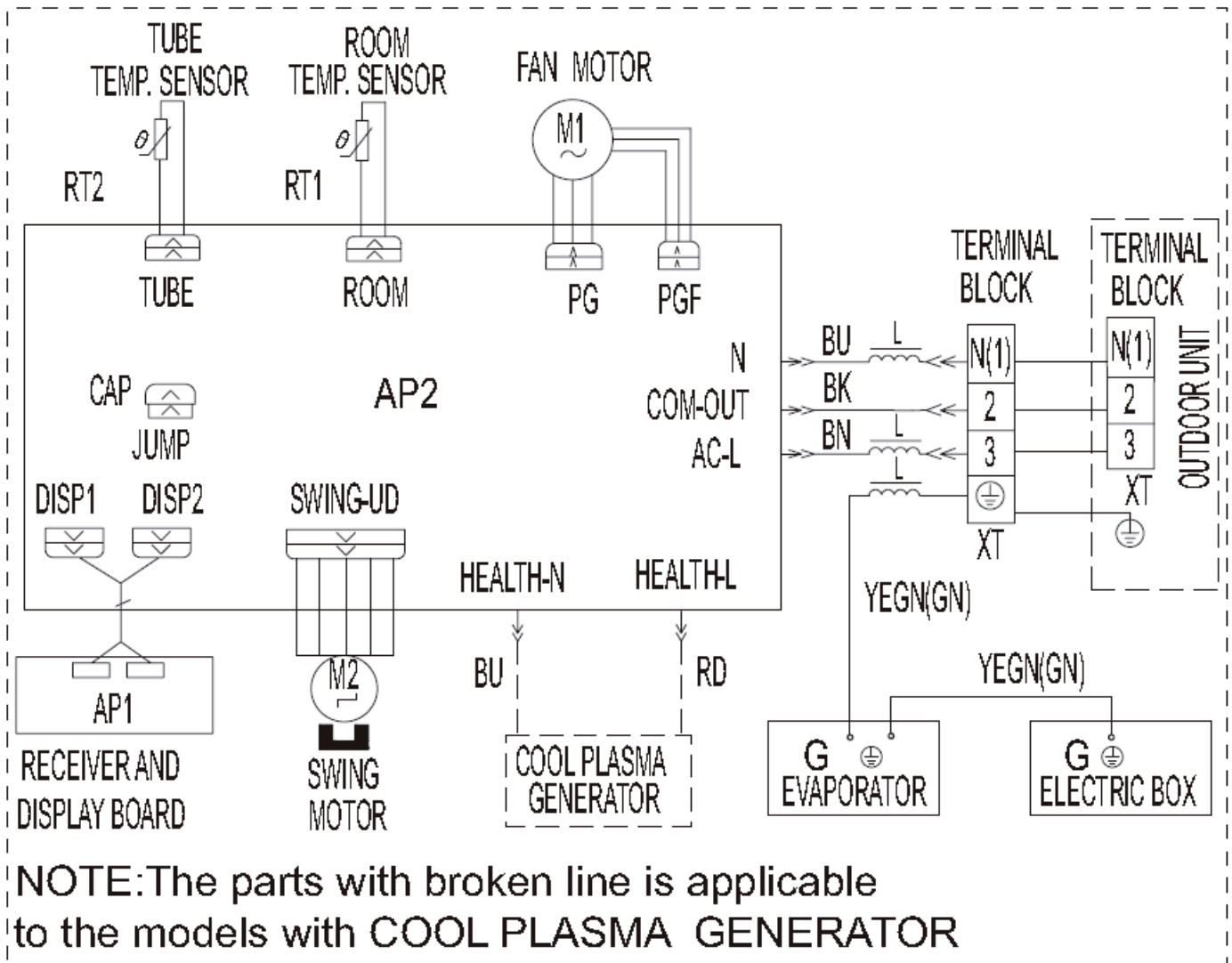

Circuit diagrams are subject to change without notice, please refer to the one supplied with the unit.

Electrical Schematics

NEO18HP230V1AO 230v

Outdoor Board

Symbol	Color Symbol	Symbol	Color Symbol
OG	Orange		Earth Ground
WH	White	COMP.	Compressor
YE	Yellow	CT1,2	Overload
RD	Red	4V	4-Way Valve
YEGN	Yellow-Green	XT	Terminal Block
BN	Brown	Vt	Violet
BU	Blue		
BK	Black		

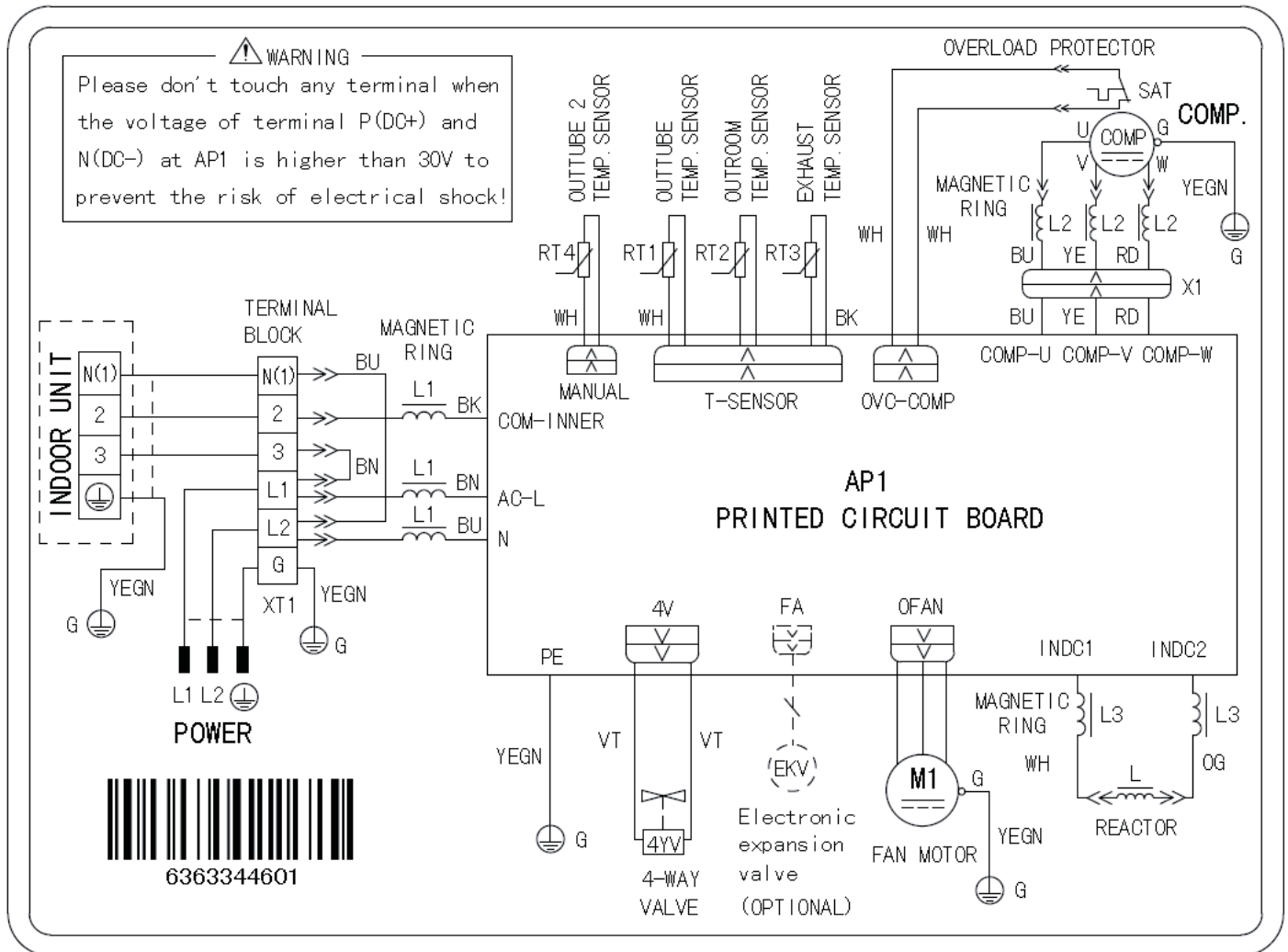

Circuit diagrams are subject to change without notice, please refer to the one supplied with the unit.

Electrical Schematics

NEO24HP230V1AH 230v

Indoor Board

Symbol	Color Symbol	Symbol	Color Symbol
OG	Orange		Earth Ground
WH	White	COMP.	Compressor
YE	Yellow	CT1,2	Overload
RD	Red	4V	4-Way Valve
YEGN	Yellow-Green	XT	Terminal Block
BN	Brown	VT	Violet
BU	Blue		
BK	Black		

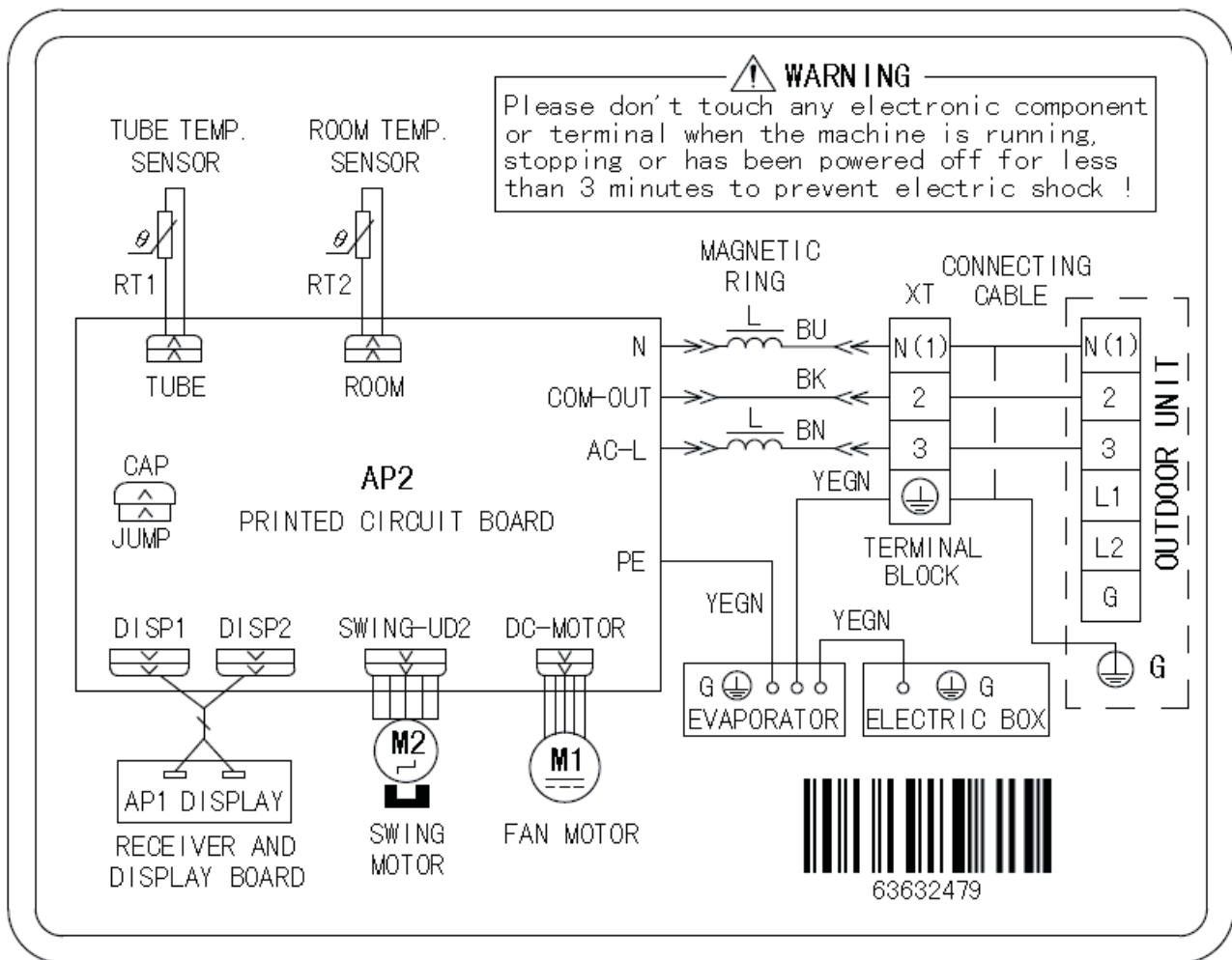

Circuit diagrams are subject to change without notice, please refer to the one supplied with the unit.

Electrical Schematics

NEO24HP230V1AO 230v

Outdoor Board

Symbol	Color Symbol	Symbol	Color Symbol
OG	Orange		Earth Ground
WH	White	COMP.	Compressor
YE	Yellow	CT1,2	Overload
RD	Red	4V	4-Way Valve
YEGN	Yellow-Green	XT	Terminal Block
BN	Brown	VT	Violet
BU	Blue		
BK	Black		

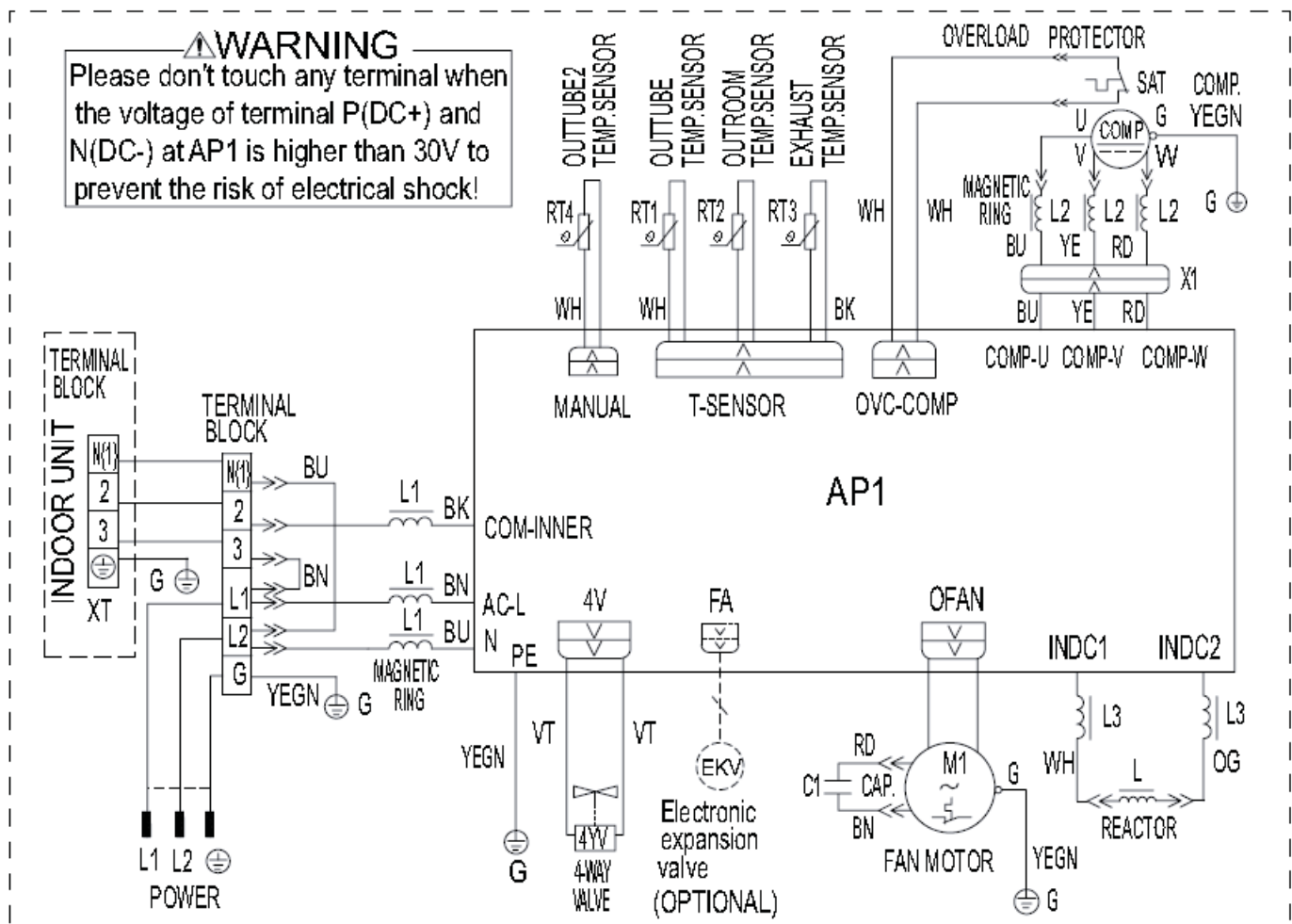

Circuit diagrams are subject to change without notice, please refer to the one supplied with the unit.

Electrical Schematics

NEO30HP230V1AH 230v

Indoor Board

Symbol	Color Symbol	Symbol	Color Symbol
OG	Orange		Earth Ground
WH	White	COMP.	Compressor
YE	Yellow	CT1,2	Overload
RD	Red	4V	4-Way Valve
YEGN	Yellow-Green	XT	Terminal Block
BN	Brown	VT	Violet
BU	Blue		
BK	Black		

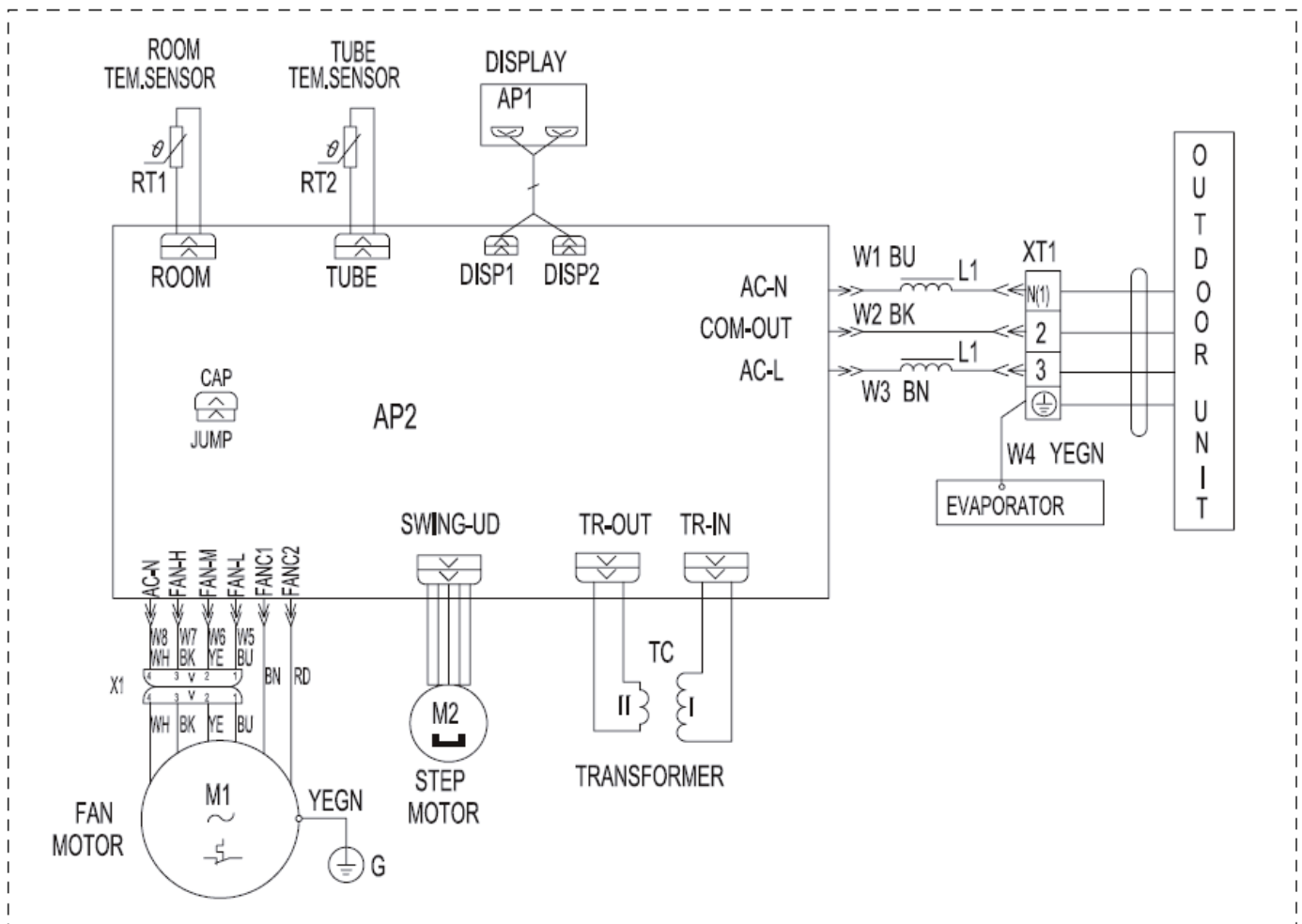

Circuit diagrams are subject to change without notice, please refer to the one supplied with the unit.

Electrical Schematics

NEO30HP230V1AO 230v

Outdoor Board

Symbol	Color Symbol	Symbol	Color Symbol
OG	Orange		Earth Ground
WH	White	COMP.	Compressor
YE	Yellow	CT1,2	Overload
RD	Red	4V	4-Way Valve
YEGN	Yellow-Green	XT	Terminal Block
BN	Brown	VT	Violet
BU	Blue		
BK	Black		

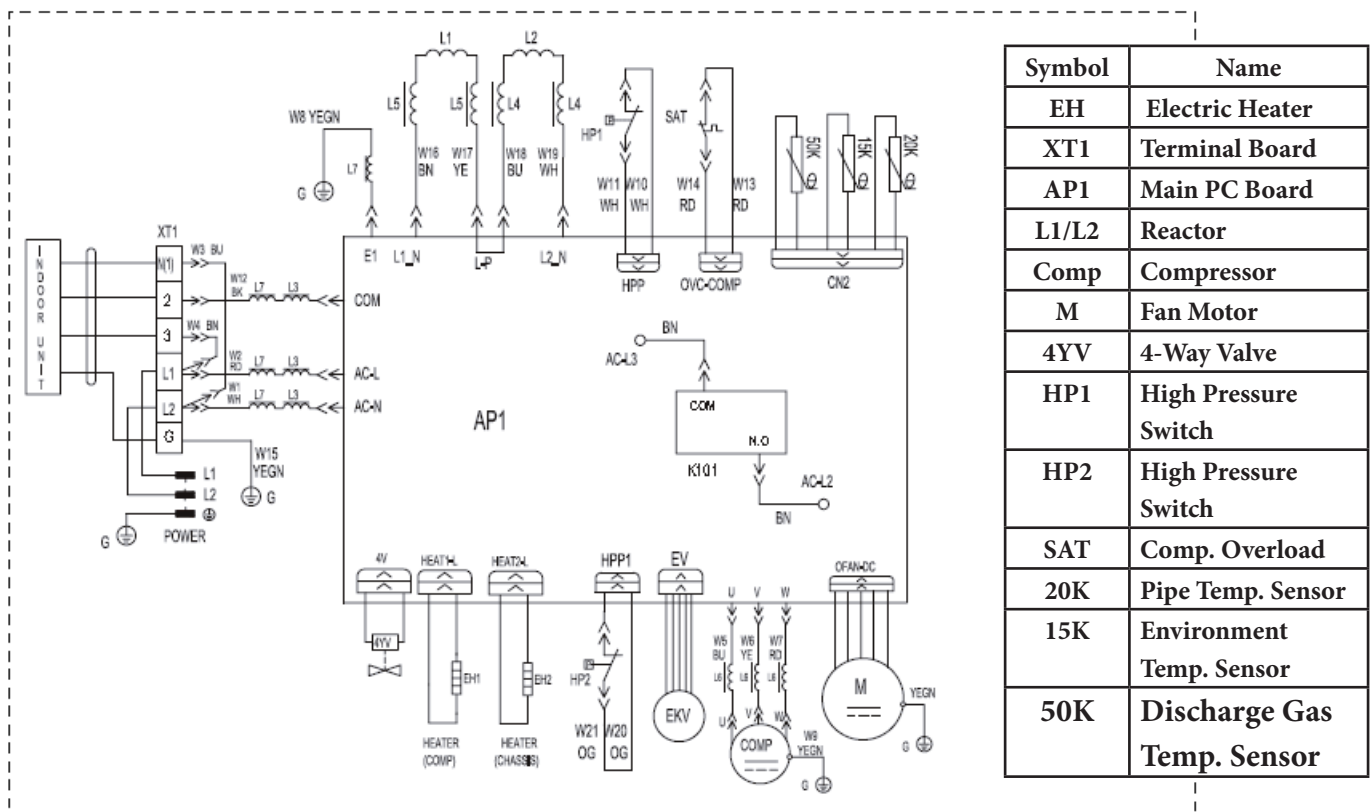

Symbol	Name
EH	Electric Heater
XT1	Terminal Board
AP1	Main PC Board
L1/L2	Reactor
Comp	Compressor
M	Fan Motor
4YV	4-Way Valve
HP1	High Pressure Switch
HP2	High Pressure Switch
SAT	Comp. Overload
20K	Pipe Temp. Sensor
15K	Environment Temp. Sensor
50K	Discharge Gas Temp. Sensor

Circuit diagrams are subject to change without notice, please refer to the one supplied with the unit.

Electrical Schematics

NEO36HP230V1AH 230v

Indoor Board

Symbol	Color Symbol	Symbol	Color Symbol
OG	Orange		Earth Ground
WH	White	COMP.	Compressor
YE	Yellow	CT1,2	Overload
RD	Red	4V	4-Way Valve
YEGN	Yellow-Green	XT	Terminal Block
BN	Brown		
BU	Blue		
BK	Black		

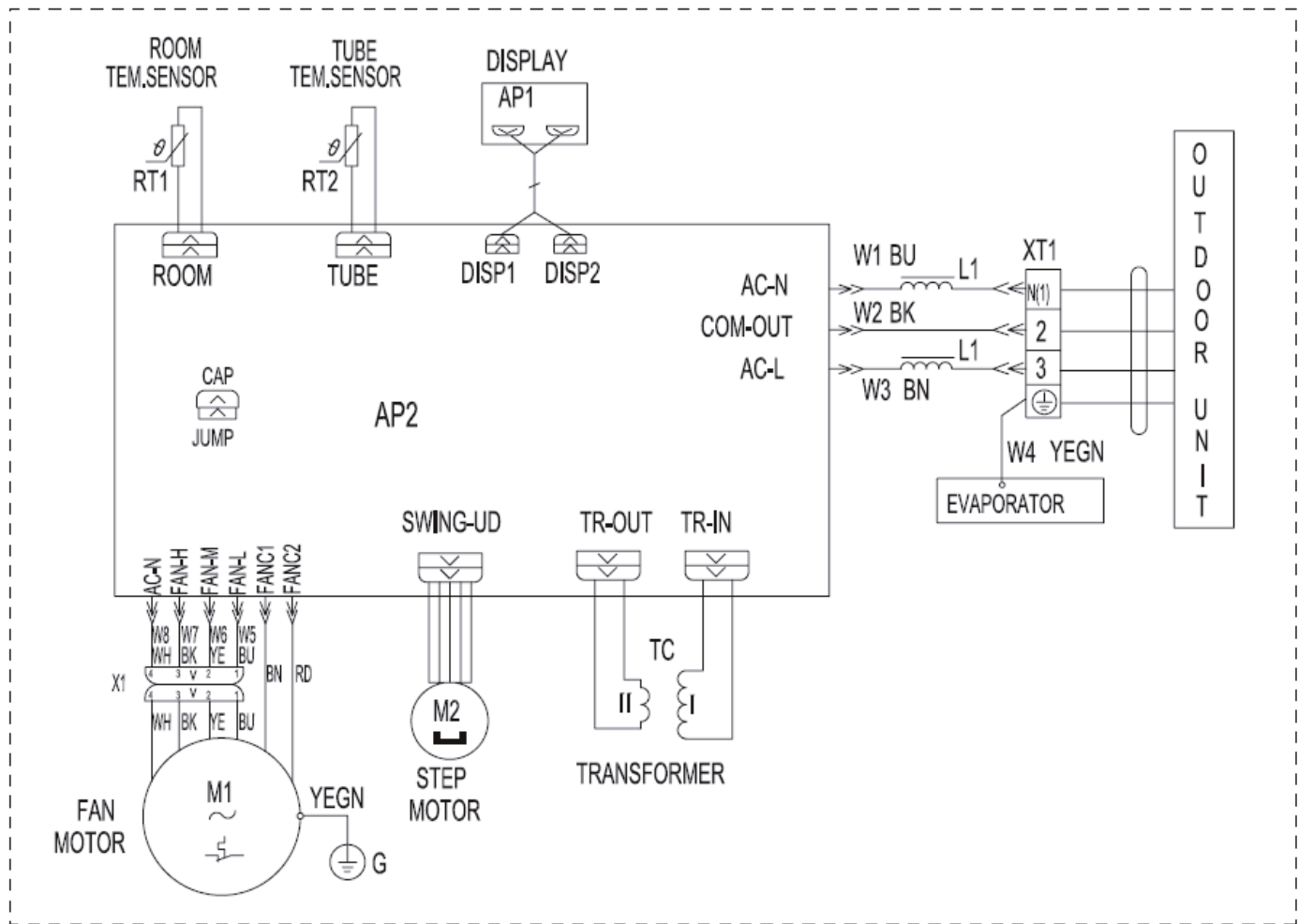

Circuit diagrams are subject to change without notice, please refer to the one supplied with the unit.

Electrical Schematics

NEO36HP230V1AO 230v

Outdoor Board

Symbol	Color Symbol	Symbol	Color Symbol
OG	Orange		Earth Ground
WH	White	COMP.	Compressor
YE	Yellow	CT1,2	Overload
RD	Red	4V	4-Way Valve
YEGN	Yellow-Green	XT	Terminal Block
BN	Brown	VT	Violet
BU	Blue		
BK	Black		

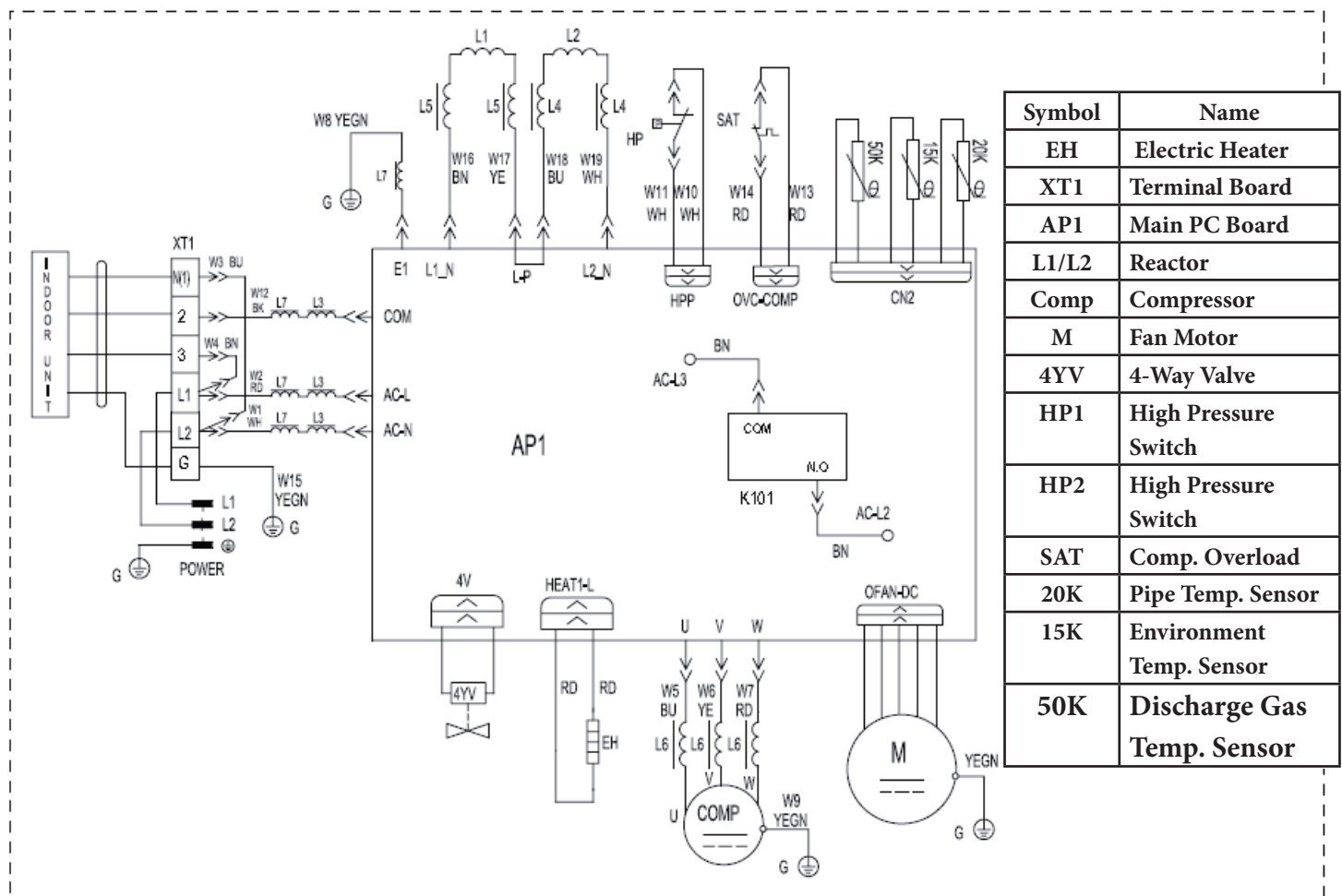

Circuit diagrams are subject to change without notice, please refer to the one supplied with the unit.

Printed Circuit Boards

AP-1 Circuit Board

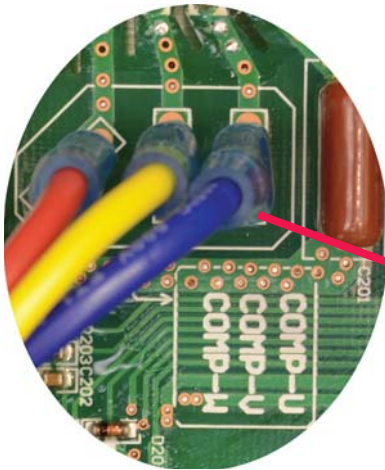

Compressor Wires

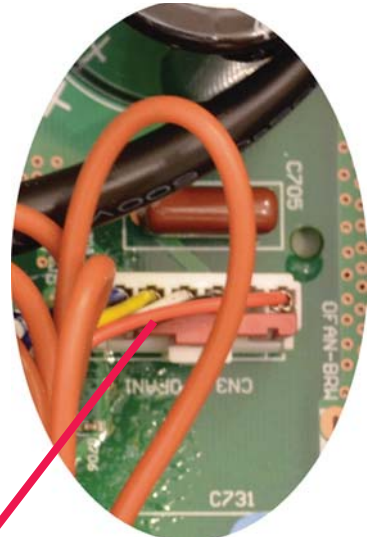

Outdoor Fan Wires

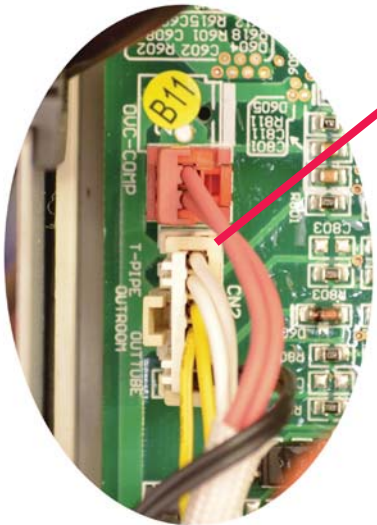

Thermistor wires

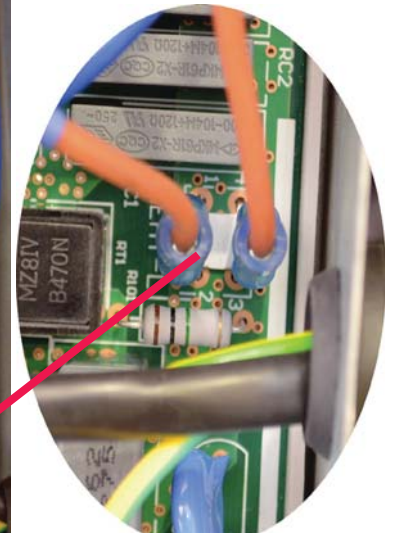
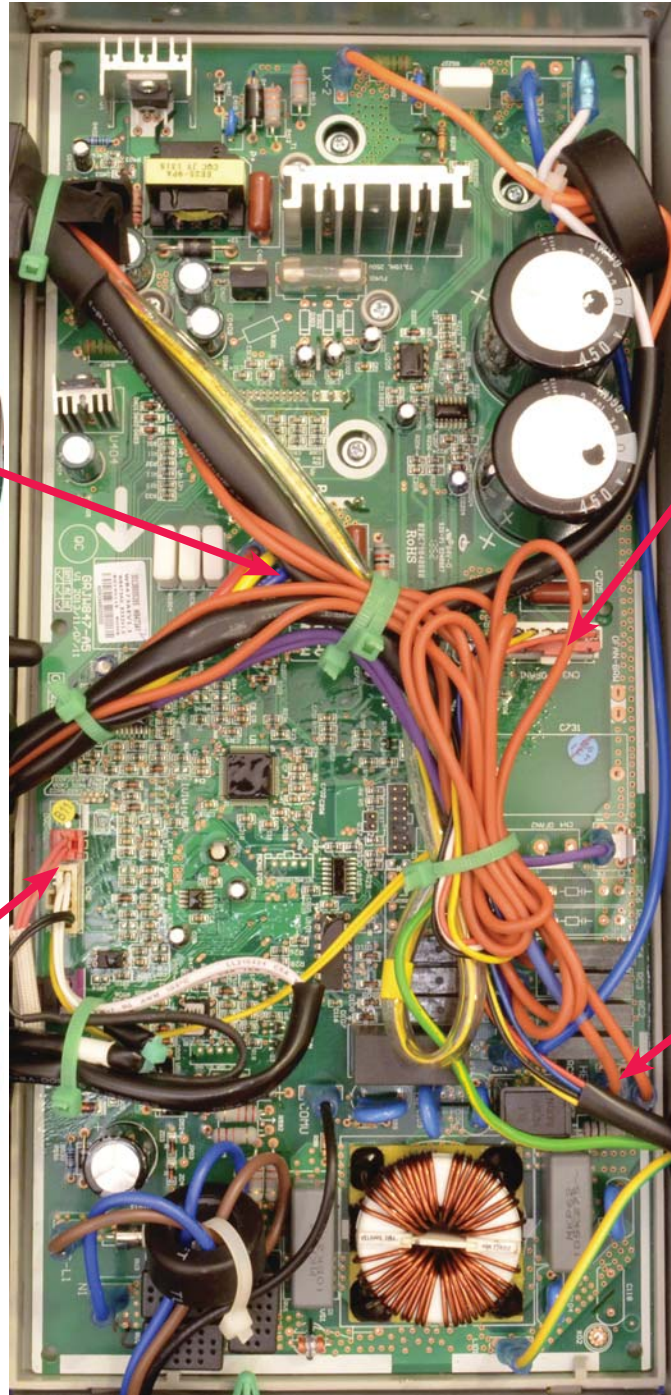

Compressor Heater Band

Troubleshooting Indoor Components

Indoor Fan Motor Troubleshooting

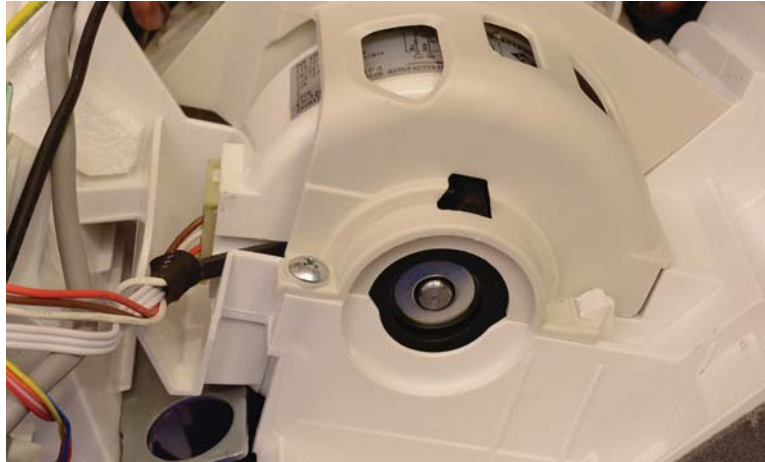

To check the condition of the indoor fan motor voltage measurements and resistance measurements can be compared to the following charts. Care must be taken when checking voltage measurements, all wires and terminals must be isolated for safety. Resistance measurements must be taken with power off and “PG” connector removed from the circuit board.

The following chart indicates approximate voltage measurements, readings may vary slightly depending on models and should be used as a reference only. Voltages should be taken with unit running.

PG Wire Connector	Low	Medium	High	Turbo
Brown - White	130 vac	147 vac	161 vac	225 vac
Brown - Red	148 vac	184 vac	210 vac	340 vac
White - Red	123 vac	150 vac	180 vac	205 vac

The following chart indicates approximate resistance measurements, readings may vary slightly depending on models and should be used as a reference only. Turn power off and remove connector from circuit board before reading measurements.

PG Wire Connector	Resistance (ohms)
Brown - White	160 Ω
Brown - Red	400 Ω
White - Red	240 Ω

Troubleshooting Indoor Components

Step Motor Troubleshooting



To check the condition of the indoor step (swing) motor resistance measurements may be compared to the following chart. Resistance measurements must be taken with power off and the connector removed from the board. The following charts indicates approximate readings and may vary with different models. **Turn power off and remove connector from circuit board.**

Connector	Blue	Pink	Yellow	Orange	Red
Blue		390 Ω	390 Ω	390 Ω	195 Ω
Pink			390 Ω	390 Ω	195 Ω
Yellow				390 Ω	195 Ω
Orange					195 Ω
Red					

Troubleshooting Outdoor Components

EEV Troubleshooting

Cooling Mode

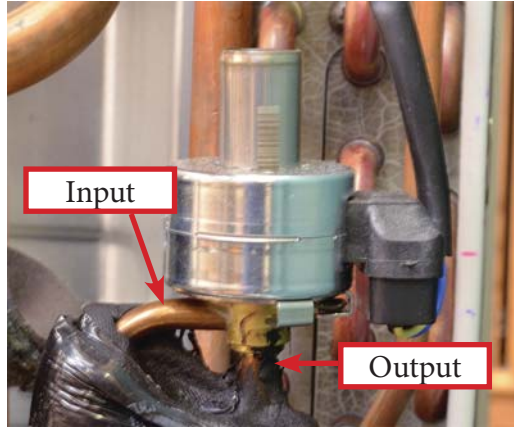

To check the operation of the EEV Valve in cooling mode, using a digital thermometer record the temperature of the input line and the output line of the valve as indicated in the picture above. With the compressor running, the input side of the valve should have a higher reading than the output side indicating that the valve is metering. If the temperature readings are the same, the valve is fully open and the valve is not metering. Since the pressures and frequency are controlled by the G10 technology of the outdoor circuit board, there are no pressure checks that can be made.

Heating Mode

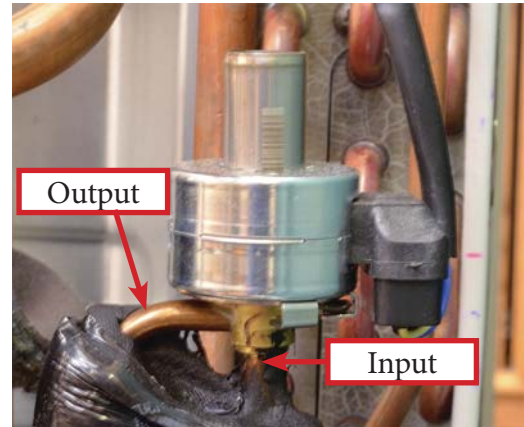

To check the operation of the EEV Valve in heating mode, using a digital thermometer record the temperature of the input line and the output line of the valve as indicated in the picture above. With the compressor running, the input side of the valve should have a higher reading than the output side indicating that the valve is metering. If the temperature readings are the same, the valve is fully open and the valve is not metering. Since the pressures and frequency are controlled by the G10 technology of the outdoor circuit board, there are no pressure checks that can be made.

Resistance readings of EEV valve with wire plug disconnected from circuit board. Power to unit should be off when making resistance readings. Readings below are approximate values and may vary slightly with different outdoor models.

EEV Ω	Orange	Red	Yellow	Black	Blue
Orange		94.6 Ω	94.8 Ω	94.4 Ω	47.0 Ω
Red			94.7 Ω	94.4 Ω	47.5 Ω
Yellow				94.6 Ω	47.7 Ω
Black					47.4 Ω
Blue					

Troubleshooting Outdoor Components

4-Way Valve Troubleshooting

Cooling Mode

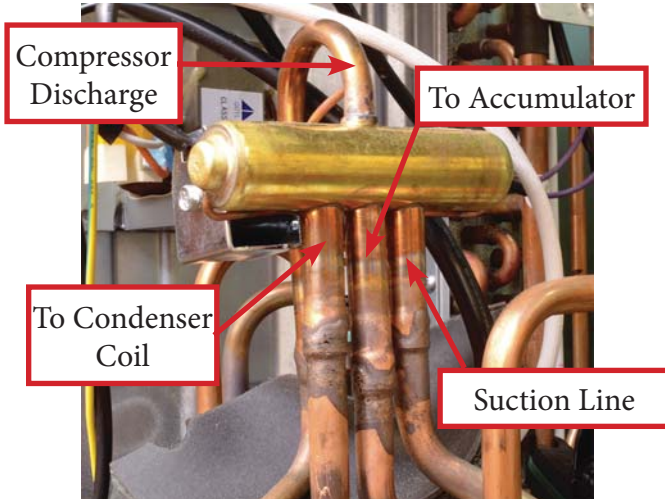

Checking the 4-way valve in cooling mode requires the measurement of 4 readings. First record the temperature of the compressor discharge tubing, secondly record the temperature of the tubing going to the condenser. There should be no more than a 10 degrees difference between the two readings.

The next set of readings will require recording the temperature of the tubing going to the suction line and the temperature of the tubing going to the accumulator. Again, if there should be less than 10 degrees difference between these readings.

A temperature reading higher than 10 degrees may indicate a leaky valve (not fully shifter) or a blockage in the valve.

4-Way valve solenoid resistance check:

Be sure all power is off to the unit. Remove the plug connecting the 4-way valve to the circuit board. Check the resistance with an ohmmeter. The reading should indicate 1.8k Ω . If the reading is infinite, replace the solenoid coil.

Heating Mode

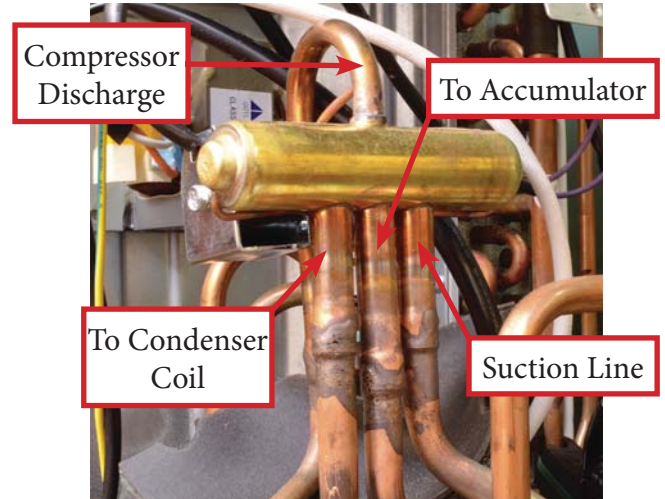

Checking the 4-way valve in heating mode requires the measurement of 4 readings. First record the temperature of the compressor discharge tubing, secondly record the temperature of the suction line tube. There should be no more than a 10 degrees difference between the two readings.

The next set of readings will require recording the temperature of the tubing going to the condenser coil and the temperature of the tubing going to the accumulator. Again, if there should be less than 10 degrees difference between these readings.

A temperature reading higher than 10 degrees may indicate a leaky valve (not fully shifter) or a blockage in the valve.

Troubleshooting Outdoor Components

Temperature Sensor Check

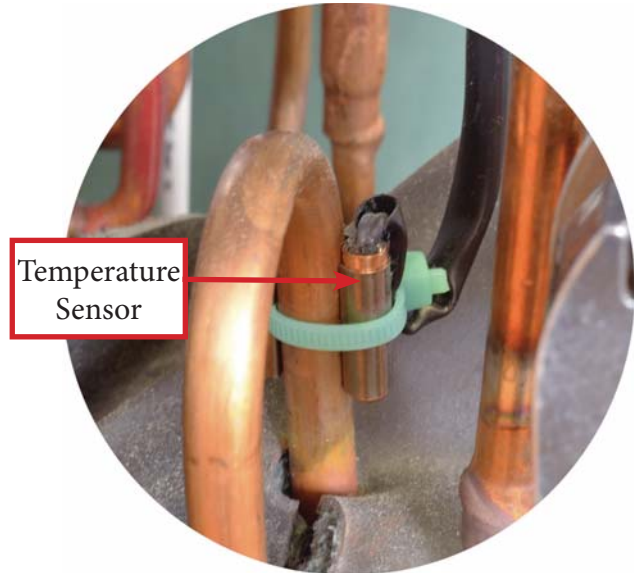

Using a glass of ice water, place the sensor into the glass with a digital thermometer. Wait a few minutes for the reading to stabilize. Compare the readings to the sensor tables in Appendix “A”, if the readings are not comparable, replace the sensor. When replacing the sensor, be sure to fasten the sensor securely if it is attached to a tube.

Temp (°C)	Temp (°F)	Resistance (kΩ)		Temp (°C)	Temp (°F)	Resistance (kΩ)		Temp (°C)	Temp (°F)	Resistance (kΩ)
0	32.0	49.02		52	125.6	4.986		104	219.2	0.898
1	33.8	46.6		53	127.4	4.802		105	221.0	0.873
2	35.6	44.31		54	129.2	4.625		106	222.8	0.848
3	37.4	42.14		55	131.0	4.456		107	224.6	0.825
4	39.2	40.09		56	132.8	4.294		108	226.4	0.802
5	41.0	38.15		57	134.6	4.139		109	228.2	0.779
6	42.8	36.32		58	136.4	3.99		110	230.0	0.758
7	44.6	34.58		59	138.2	3.848		111	231.8	0.737
8	46.4	32.94		60	140.0	3.711		112	233.6	0.717
9	48.2	31.38		61	141.8	3.579		113	235.4	0.697

Troubleshooting Outdoor Components

Compressor Windings

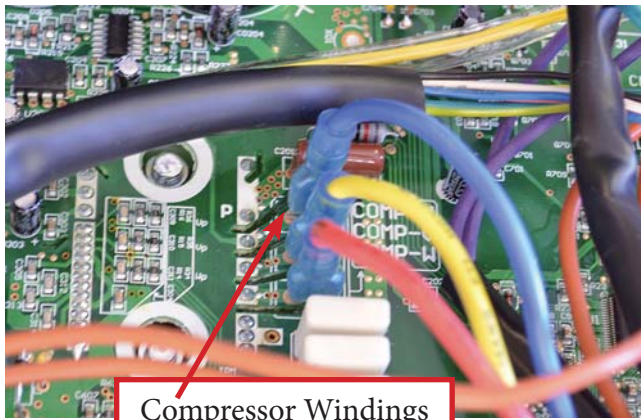

Compressor Windings
Red, Yellow & Blue Wires

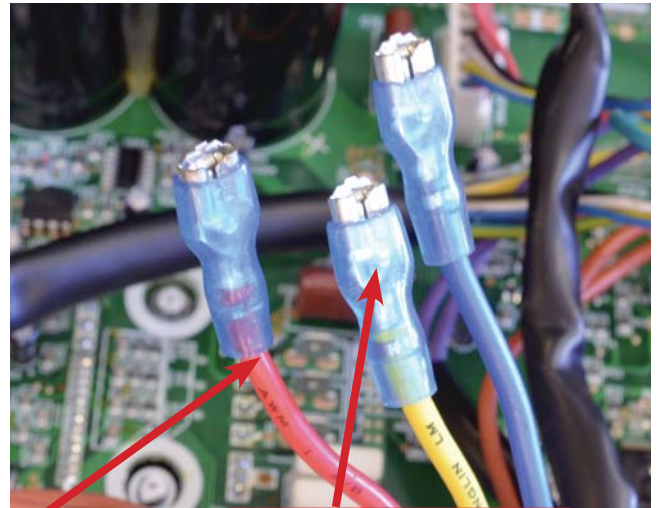

Slightly depress tab for
easy removal

Compressor Winding Resistance Check:

Remove the compressor wires from the AP1 circuit board. The wires red to yellow, yellow to blue & red to blue should have readings from 2 - 4 ohms. There should be no reading from any wire to chassis ground. If the readings between the windings differ greatly, the windings are bad. If there is a reading from any wire to the chassis, there is leakage in the windings.

Reactor

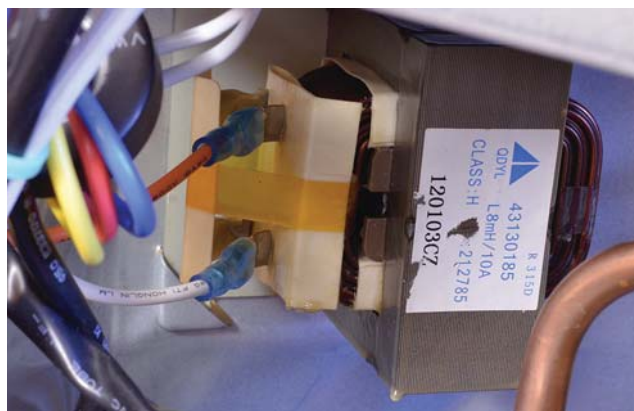

The reactor filters out electrical noise and transient voltage spikes to the control board. There will be a reading of less than 1 Ω after the wires are removed. There should be no reading from either reactor terminal to ground.

Troubleshooting Outdoor Components

Outdoor Fan Motor



Outdoor Motor Winding Resistance Check:

Disconnect power to the unit, all readings are made with no power and fan motor wires disconnected from circuit board.

Remove the white and orange wire from the reactor and then disconnect the plug from the circuit board. The chart below will indicate the approximate resistance values in ohms. Readings may vary slightly for different models. This is a DC brush-less motor, resistance readings may vary with meters. Plugging a know good motor in the board would provide a quick troubleshooting technique.

Motor Leads (Negative Meter Lead this color)	Blue	Yellow	Black	White	Red
Blue		6.6M Ω	6.2M Ω	6.3M Ω	~ Ω
Yellow			51K Ω	260K Ω	~ Ω
Black				27M Ω	~ Ω
White					~ Ω
Red					

Troubleshooting Outdoor Components

Reactor



Reactor Resistance Check:

The line reactor helps to smooth the inrush current, reduce harmonics and noise, and buffers the system, protecting the electronics from transient voltage noise. The resistance between the coils will be very low, approximately .3 ohms and should not have any resistance to ground. You should disconnect the wires from the reactor before taking any readings.

Compressor Crankcase Heater Check



Compressor Crankcase Heater Resistance Check:

Unplug the wire connector from the circuit board. The resistance should read approximately 2.15K ohms. There should be no reading from either wire to ground. If readings vary from these measurements, replace the heater.

Troubleshooting Outdoor Components

Gas Line Temperature Sensors Motor

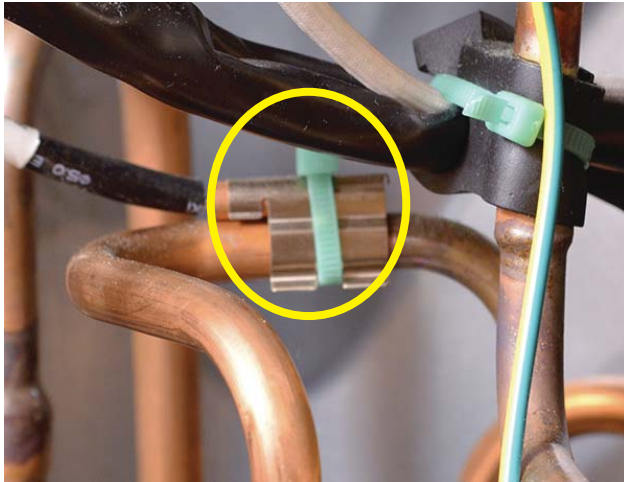

These sensors are a negative coefficient thermistor that decrease in resistance as the temperature increases. The sensors are used to monitor the temperature of the refrigerant leaving the indoor coil to maintain a correct superheat operation. Please refer to the troubleshooting section for error codes generated by a sensor fault.

Troubleshooting Outdoor Components

Liquid Line Temperature Sensors



These sensors are a negative coefficient thermistor that decrease in resistance as the temperature increases. The sensors are used to monitor the temperature of the refrigerant leaving the EEV to maintain a correct superheat operation. Please refer to the troubleshooting section for error codes generated by a sensor fault.

Troubleshooting Outdoor Components

High Pressure Protection Switch & Exhaust Temperature Sensor

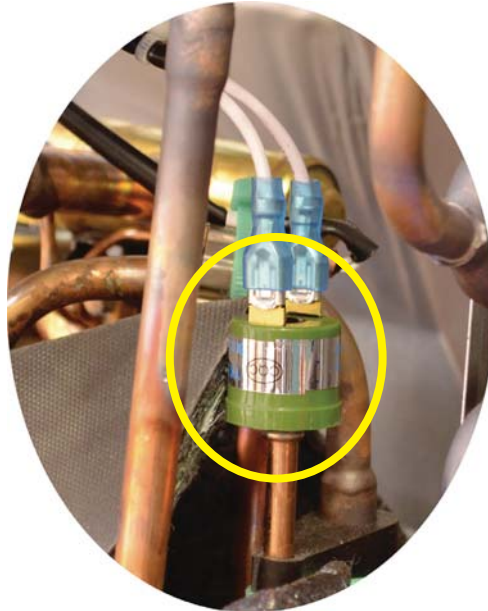

The high pressure switch monitors the refrigerant discharge pressure and will shut down the unit if pressures are higher abnormal. If this is detected, an E1 error code will be generated. Please refer to the troubleshooting section for more detailed information.



The exhaust temperature sensor monitors the refrigerant discharge temperature and will send information to the inverter control board for system operation.

The following actions can occur:

Exhaust Temperature > 208 F - Compressor will not rise above present level

Exhaust Temperature > 217 F - Compressor will run at reduced frequency

Exhaust Temperature < 194 F - Compressor off for 3 minutes minimum, the compressor will restart

Error Code F5 will be generated if the sensor is open or shorted. Please refer to the troubleshooting section for more detailed information.

Troubleshooting Outdoor Components

Outdoor Temperature Sensor

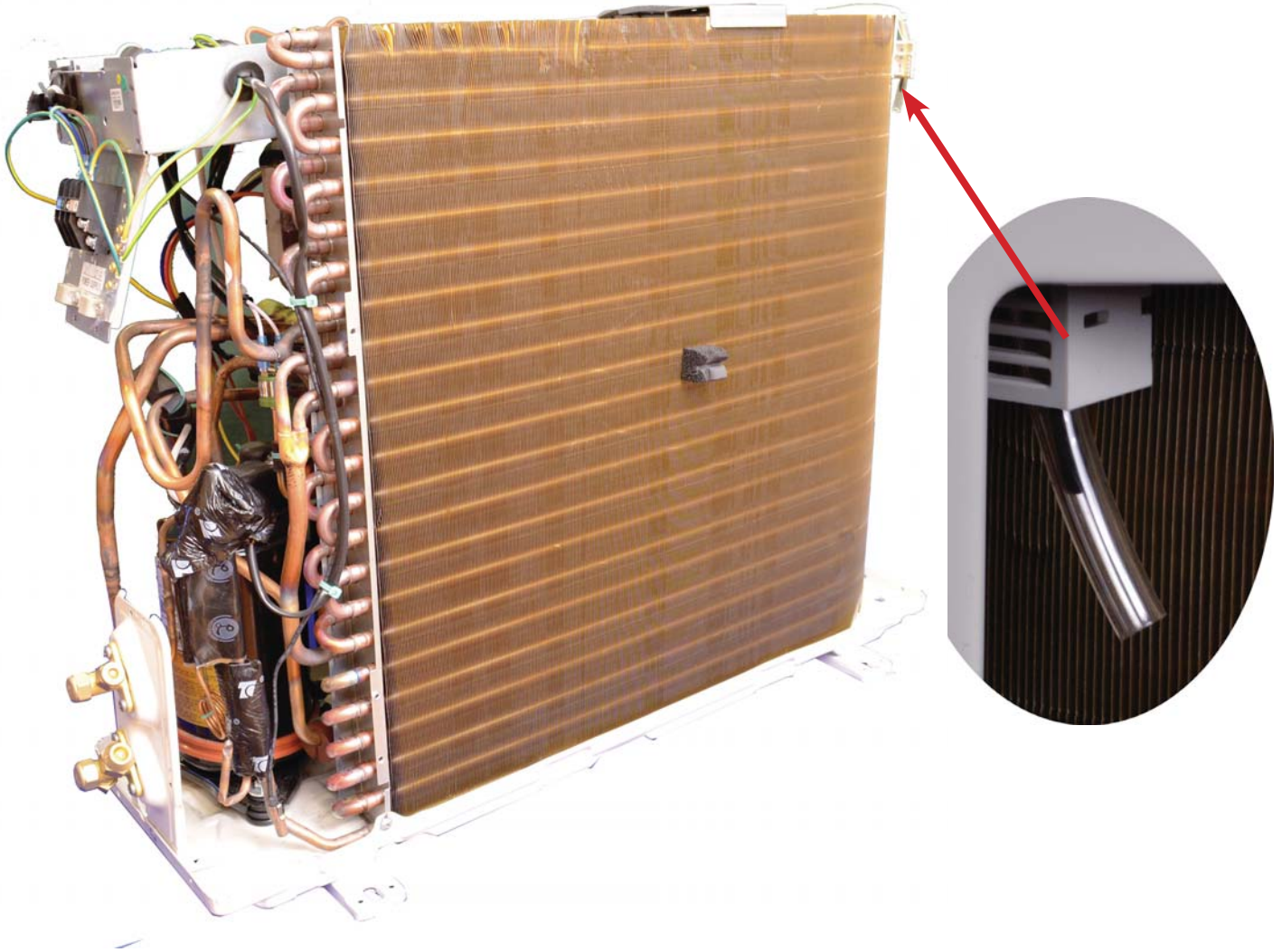

This sensor is a negative coefficient thermistor that will decrease in resistance as the temperature increases. This sensor will monitor the temperature of the outdoor air. The reading will be used by the inverter board to adjust frequency calculations.

Error Code F3 will be generated if the sensor is open or shorted. Please refer to the troubleshooting section for more detailed information.

Fault Displays

Models NEO09HP115V1AS & NEO12HP115V1AS Table 1

Error Item	Indoor Unit Display	State of Outdoor Unit LEDs F Flashing Times			Possible Cause of Fault
		Green LED	Red LED	Yellow LED	
Stop for anti-freezing protection of indoor unit	E2			blink 3 times	refrigerant leakage, indoor unit air flow blocked up, filter duty
Stop for exhaust protection	E4			blink 7 times	less refrigerant, capillary blocked up, ambient temperature is abominable
Stop for low voltage protection	E5			blink 5 times	low, voltage, ambient temperature is abominable
Stop for communication malfunction	E6			Always On	communication line failure, main PCB failure, interfere source, connect line wrong
Stop for compressor overload protection	H3			blink 8 times	compressor shell over heat, less refrigerant, capillary blocked up
Overload protection	H4			blink 6 times	ambient temperature is abominable, heat exchanger blocked up
Stop for IPM module protection	H5			blink 4 times	IPM module over heat, low voltage
DC motor (indoor unit) does not operate	H6				DC motor control terminal does not contact well, Blade does not rotate fluently due to incorrect installation; motor or control panel is damaged
Indoor ambient temperature sensor malfunction	F1				terminal connect not reliable, temperature sensor malfunction
Indoor tube temperature sensor malfunction	F2				terminal connect not reliable, temperature sensor malfunction

Fault Displays

Models NEO09HP115V1AS & NEO12HP115V1AS Table 1

Error Item	Indoor Unit Display	State of Outdoor Unit LEDs F Flashing Times			Possible Cause of Fault
		Green LED	Red LED	Yellow LED	
Outdoor ambient temperature sensor malfunction	F3		blink 6 times		terminal connect not reliable, temperature sensor malfunction
Outdoor tube temperature sensor malfunction	F4		blink 5 times		terminal connect not reliable, temperature sensor malfunction
Outdoor exhaust temperature sensor malfunction	F5		blink 7 times		terminal connect not reliable, temperature sensor malfunction
Automatic defrosting	H1			blink 2 times	H1 is not error code, it is normal operation, just heat pump has this function
REMARK:	1. Error codes only can be seen in the type which has the temperature display PCB, maybe some type has not this function, the lamps on the outdoor PCB are available; 2. Normally, the communication between indoor unit and outdoor unit is successful, the gree lamp.				

Fault Displays

Models NEO09HP230V1AS & NEO12HP230V1AS

Malfunction Name	Indoor Unit			Outdoor Unit			A/C Status	Possible Causes	
	Dual-8 Code Display	Indicator Display (during blinking, ON 0.5s and OFF 0.5s)			Indicator has 3 kinds of display status and during blinking, ON 0.5s and OFF 0.5s				
		Operation	Cool	Heating	Yellow	Red			Green
High pressure protection of system	E1	OFF 3S and blink once						During cooling and drying operation, except indoor fan operates, all loads stop operation. During heating operation, the complete unit stops	Possible reasons: 1. Refrigerant was superabundant; 2. Poor heat exchange (including filth blockage of heat exchanger and bad radiating environment); Ambient temperature is too high
Anti-freezing protection	E2	OFF 3S and blink twice			Off 3S and blink 3 times			During cooling and drying operation, compressor and outdoor fan stop while indoor fan operates	1. Poor air-return in indoor unit; 2. Fan speed is abnormal; 3. Evaporator is dirty
System block or refrigerant leakage	E3	Off 3S and blink 3 times				Off 3S and blink 9 times		The Dual-8 Code Display will show E3 until the low pressure switch stop operation	1. Low-pressure protection; 2. Low-pressure protection of system; 3. Low-pressure protection of compressor
High discharge temperature protection of compressor	E4	Off 3S and blink 4 times			Off 3S and blink 7 times			During cooling and drying operation, compressor and outdoor fan stop while indoor fan operates. During heating operation, all loads stop.	Please refer to the malfunction analysis (discharge protection, overload)
Over-current protection	E5	Off 3S and blink 5 times			Off 3S and blink 5 times			During cooling and drying operation, compressor and outdoor fan stop while indoor fan operates. During heating operation, all loads stop.	1. Supply voltage is unstable; 2. Supply voltage is too low and load is too high; 3. Evaporator is dirty

Fault Displays

Models NEO09HP230V1AS & NEO12HP230V1AS

Malfunction Name	Indoor Unit				Outdoor Unit			A/C Status	Possible Causes
	Dual-8 Code Display	Indicator Display (during blinking, ON 0.5s and OFF 0.5s)			Indicator has 3 kinds of display status and during blinking, ON 0.5s and OFF 0.5s				
		Operation	Cool	Heating	Yellow	Red	Green		
Communication Malfunction	E6	Off 3S and blink 6 times			Always On			During cooling operation, compressor stops while indoor fan motor operates. During heating operation, the complete unit stops.	Refer to the malfunction analysis
High temperature resistant protection	E8	Off 3S and blink 8 times			Off 1S and blink 6 times			During cooling operation, compressor stops while indoor fan motor operates. During heating operation, the complete unit stops.	Refer to the malfunction analysis
EEPROM malfunction	EE			Off 3S and blink 15 times	Off 1S and blink 6 times			During cooling operation, compressor stops while indoor fan motor operates. During heating operation, the complete unit stops.	Replace outdoor control panel AP1
Limit/decrease frequency due to high temperature of module	EU		Off 3S and blink 6 times	Off 3S and blink 6 times				All load operate normally, while operation frequency for compressor is decreased	Discharging after the complete unit is de-energized for 20 mins check on whether the thermal grease on IPM Module of outdoor control panel AP1 is sufficient and whether the radiator is inserted tightly. If its no use, please replace control panel AP1.
Malfunction protection of jumper cap	C5	Off 3S and blink 15 times						Wireless remote receiver and button are effective, but can not dispose the related command	1. No jumper cap insert on mainboard; 2. Incorrect insert of jumper cap; 3. Jumper cap damaged; 4. Abnormal detecting circuit of mainboard
Gathering refrigerant	F0	Off 3S and blink 1 times	Off 3S and blink 1 times		Off 1S and blink 17 times			When the outdoor unit receives signal of gathering refrigerant, the system will be forced to run under cooling mode for gathering refrigerant	Nominal cooling mode

Fault Displays

Models NEO09HP230V1AS & NEO12HP230V1AS

Malfunction Name	Indoor Unit			Outdoor Unit			A/C Status	Possible Causes	
	Dual-8 Code Display	Indicator Display (during blinking, ON 0.5s and OFF 0.5s)			Indicator has 3 kinds of display status and during blinking, ON 0.5s and OFF 0.5s				
		Operation	Cool	Heating	Yellow	Red			Green
Indoor ambient temperature sensor is open/short circuited	F1		Off 3S and blink 1 times				During cooling and drying operating, compressor stops while indoor fan operates; During heating operation, the complete unit will stop operation.	1. Loosening or bad contact of indoor evaporator temp sensor and mainboard terminal; 2. Components on the mainboard fall; 3. Indoor evaporator temp sensor damaged; 4. Mainboard damaged.	
Indoor evaporator temperature sensor is open/short circuited	F2		Off 3S and blink twice				AC stops operation once reaches the setting temperature. Cooling, drying: internal fan motor stops operation while other loads stop operation; heating: AC stop operation	1. Loosening or bad contact of indoor evaporator temp sensor and mainboard terminal; 2. Components on the mainboard fall; 3. Indoor evaporator temp sensor damaged; 4. Mainboard damaged.	
Outdoor ambient temperature sensor is open/short circuited	F3		Off 3S and blink 3 times			Off 1S and blink 6 times	During cooling and drying operating, compressor stops while indoor fan operates; During heating operation, the complete unit will stop operation.	Outdoor temperature sensor hasn't been connected well or is damaged. Please check it by referring to the resistance table for temperature sensor.	
Outdoor condenser temperature sensor is open/short circuited	F4		Off 3S and blink 4 times			Off 1S and blink 5 times	During cooling and drying operating, compressor stops while indoor fan operates; During heating operation, the complete unit will stop operation.	Outdoor temperature sensor hasn't been connected well or is damaged. Please check it by referring to the resistance table for temperature sensor.	

Fault Displays

Models NEO09HP230V1AS & NEO12HP230V1AS

Malfunction Name	Indoor Unit			Outdoor Unit			A/C Status	Possible Causes	
	Dual-8 Code Display	Indicator Display (during blinking, ON 0.5s and OFF 0.5s)			Indicator has 3 kinds of display status and during blinking, ON 0.5s and OFF 0.5s				
		Operation	Cool	Heating	Yellow	Red			Green
Outdoor discharge temperature sensor is open/short circuited	F5		Off 3S and blink 5 times				Off 1S and blink 7 times	During cooling and drying operation, compressor will stop after operating for about 3 mins, while indoor fan will operate. During heating operation, the complete unit will stop after operating for about 3 mins.	1. Outdoor temperature sensor hasn't been connected well or is damaged. Please check it by referring to the resistance table for temperature sensor; 2. The head of temperature sensor hasn't been inserted into the copper tube.
Limit/decrease frequency due to overload	F6		Off 3S and blink 6 times				Off 1S and blink 3 times	All loads operate normally, while operation frequency for compressor is decreased.	Refer to the malfunction analysis (overload, high temperature resistant)
Decrease frequency due to overcurrent	F8		Off 3S and blink 8 times				Off 1S and blink 1 times	During cooling and drying operation, compressor will stop while indoor fan will operate. During heating operation, the complete unit will stop operation.	The input supply voltage is too low; System pressure is too high and overload
Decrease frequency due to high air discharge	F9		Off 3S and blink 9 times				Off 1S and blink 2 times	All loads operate normally, while operation frequency for compressor is decreased.	Overload or temperature is too high; Refrigerant is insufficient; Malfunction of electric expansion valve (EKV)
Limit/decrease frequency due to anti-freezing	FH		Off 3S and blink 2 times	Off 3S and blink 2 times			Off 3S and blink 4 times	All loads operate normally, while operation frequency for compressor is decreased.	Poor air-return in indoor unit or fan speed is too low

Fault Displays

Models NEO09HP230V1AS & NEO12HP230V1AS

Malfunction Name	Indoor Unit			Outdoor Unit			A/C Status	Possible Causes	
	Dual-8 Code Display	Indicator Display (during blinking, ON 0.5s and OFF 0.5s)			Indicator has 3 kinds of display status and during blinking, ON 0.5s and OFF 0.5s				
		Operation	Cool	Heating	Yellow	Red			Green
Voltage of DC bus-bar is too high	PH		Off 3S and blink 11 times		Off 3S and blink 13 times			During cooling and drying operation, compressor will stop while indoor fan will operate. During heating operation, the complete unit will stop operation. 1. Measure the voltage of position L and N on wiring board (XT), if the voltage is higher than 150VAC, turn on the unit after the supply voltage is increase to the normal range; 2. If the AC input is normal, measure the voltage of electrolytic capacitor C on control panel (AP1), if its normal, theres malfunction for the circuit, please replace the control panel (AP1)	
Voltage of DC bus-bar is too low	PL			Off 3S and blink 21 times	Off 3S and blink 12 times			During cooling and drying operation, compressor will stop while indoor fan will operate. During heating operation, the complete unit will stop operation. 1. Measure the voltage of position L and N on wiring board (XT), if the voltage is higher than 150VAC, turn on the unit after the supply voltage is increase to the normal range; 2. If the AC input is normal, measure the voltage of electrolytic capacitor C on control panel (AP1), if its normal, theres malfunction for the circuit, please replace the control panel (AP1)	
Compressor Min frequency in test state	P0		blinking in cool mode,ON 0.25s and OFF 0.25s	blinking in heat mode,ON 0.25s and OFF 0.25s				Showing during min. cooling or min. heating test	
Compressor rated frequency in test state	P1		blinking in cool mode,ON 0.25s and OFF 0.25s	blinking in heat mode,ON 0.25s and OFF 0.25s				Showing during nominal cooling or nominal heating test	

Fault Displays

Models NEO09HP230V1AS & NEO12HP230V1AS

Malfunction Name	Indoor Unit			Outdoor Unit			A/C Status	Possible Causes	
	Dual-8 Code Display	Indicator Display (during blinking, ON 0.5s and OFF 0.5s)			Indicator has 3 kinds of display status and during blinking, ON 0.5s and OFF 0.5s				
		Operation	Cool	Heating	Yellow	Red			Green
Compressor maximum frequency in test state	P2		blinking in cool mode, ON 0.25s and OFF 0.25s	blinking in heat mode, ON 0.25s and OFF 0.25s				Showing during max. cooling or max. heating test	
Compressor intermediate frequency in test state	P3		blinking in cool mode, ON 0.25s and OFF 0.25s	blinking in heat mode, ON 0.25s and OFF 0.25s				Showing during middle cooling or middle heating test	
Overcurrent protection of phase current for compressor	P5		Off 3S and blink 15 times				During cooling and drying operation, compressor will stop while indoor fan will operate. During heating operation, the complete unit will stop operation.	Refer to malfunction analysis	
Charging malfunction of capacitor	PU			Off 3S and blink 17 times			During cooling and drying operation, compressor will stop while indoor fan will operate. During heating operation, the complete unit will stop operation.	Refer to the part three-charging malfunction analysis of capacitor	
Malfunction of module temperature sensor circuit	P7			Off 3S and blink 18 times			During cooling and drying operation, compressor will stop while indoor fan will operate. During heating operation, the complete unit will stop operation.	Replace outdoor control panel AP1	

Fault Displays

Models NEO09HP230V1AS & NEO12HP230V1AS

Malfunction Name	Indoor Unit			Outdoor Unit			A/C Status	Possible Causes	
	Dual-8 Code Display	Indicator Display (during blinking, ON 0.5s and OFF 0.5s)			Indicator has 3 kinds of display status and during blinking, ON 0.5s and OFF 0.5s				
		Operation	Cool	Heating	Yellow	Red			Green
Module high temperature protection	P8			Off 3S and blink 19 times				During cooling and drying operation, compressor will stop while indoor fan will operate. During heating operation, the complete unit will stop operation. After the complete unit is de-energized for 20 mins, check whether the thermal grease on the IPM Module of outdoor control panel AP1 is sufficient and whether the radiator is inserted tightly. If its no use, please replace control panel AP1	
Decrease frequency due to high temperature resistant during heating operation	H0			Off 3S and blink 10 times				All loads operate normally, while operation frequency for compressor is decreased. Refer to the malfunction analysis (overload, high temperature resistant)	
Static dedusting protection	H2			Off 3S and blink 2 times					
Overload protection of compressor	H3			Off 3S and blink 3 times	Off 1S and blink 8 times			During cooling and drying operation, compressor will stop while indoor fan will operate. During heating operation, the complete unit will stop operation. 1. Wiring terminal OVC-COMP is loosened. In normal state, the resistance for this terminal should be less than 1ohm; 2. Refer to the malfunction analysis.	
System is abnormal	H4			Off 3S and blink 4 times	Off 1S and blink 6 times			During cooling and drying operation, compressor will stop while indoor fan will operate. During heating operation, the complete unit will stop operation. Refer to the malfunction analysis (overload, high temperature resistant)	

Fault Displays

Models NEO09HP230V1AS & NEO12HP230V1AS

Malfunction Name	Indoor Unit			Outdoor Unit			A/C Status	Possible Causes	
	Dual-8 Code Display	Indicator Display (during blinking, ON 0.5s and OFF 0.5s)			Indicator has 3 kinds of display status and during blinking, ON 0.5s and OFF 0.5s				
		Operation	Cool	Heating	Yellow	Red			Green
IPM protection	H5			Off 3S and blink 5 times	Off 1S and blink 4 times			During cooling and drying operation, compressor will stop while indoor fan will operate. During heating operation, the complete unit will stop operation.	Refer to the malfunction analysis (IPM protection, loss of synchronism protection, and overcurrent protection of phase current for compressor)
Module temperature is too high	H5			Off 3S and blink 5 times	Off 1S and blink 10 times				
Internal motor (fan motor) do not operate	H6	Off 3S and blink 11 times						Internal fan motor, external fan motor, compressor and electric heater stop operation, guide louver stops at present location	1. Bad contact of DC motor feedback terminal; 2. Bad contact of DC motor control end; 3. Fan motor is stalling; 4. Motor malfunction; 5. Malfunction of mainboard rev detecting circuit
Desynchronizing of compressor	H7			Off 3S and blink 7 times				During cooling and drying operation, compressor will stop while indoor fan will operate. During heating operation, the complete unit will stop operation.	Refer to the malfunction analysis (IPM protection, loss of synchronism protection, and overcurrent protection of phase current for compressor)
PFC protection	HC			Off 3S and blink 6 times	Off 3S and blink 14 times			During cooling and drying operation, compressor will stop while indoor fan will operate. During heating operation, the complete unit will stop operation.	Refer to the malfunction analysis

Fault Displays

Models NEO09HP230V1AS & NEO12HP230V1AS

Malfunction Name	Indoor Unit			Outdoor Unit			A/C Status	Possible Causes	
	Dual-8 Code Display	Indicator Display (during blinking, ON 0.5s and OFF 0.5s)			Indicator has 3 kinds of display status and during blinking, ON 0.5s and OFF 0.5s				
		Operation	Cool	Heating	Yellow	Red			Green
Outdoor DC fan motor malfunction	L3	Off 3S and blink 23 times				Off 3S and blink 14 times		Outdoor DC fan motor malfunction lead to compressor stop operation DC fan motor malfunction or system blocked or the connector loosed	
Power protection	L9	Off 3S and blink 20 times			Off 3S and blink 9 times			Compressor stop operation and Outdoor fan motor will stop 30s later, 3 minutes later fan motor and compressor will restart To protect the electronic components when detect high power	
Indoor unit and outdoor unit doesn't match	LP	Off 3S and blink 19 times			Off 3S and blink 16 times			Compressor and Outdoor fan motor can't work Indoor unit and outdoor unit doesn't match	
Failure start-up	LC			Off 3S and blink 11 times				During cooling and drying operation, compressor will stop while indoor fan will operate. During heating operation, the complete unit will stop operation. Refer to the malfunction analysis	
Malfunction of phase current detection circuit for compressor	U1			Off 3S and blink 13 times				During cooling and drying operation, compressor will stop while indoor fan will operate. During heating operation, the complete unit will stop operation. Replace outdoor control panel AP1	
Malfunction of voltage dropping for DC bus-bar	U3			Off 3S and blink 20 times				During cooling and drying operation, compressor will stop while indoor fan will operate. During heating operation, the complete unit will stop operation. Supply voltage is unstable	

Fault Displays

Models NEO09HP230V1AS & NEO12HP230V1AS

Malfunction Name	Indoor Unit			Outdoor Unit			A/C Status	Possible Causes	
	Dual-8 Code Display	Indicator Display (during blinking, ON 0.5s and OFF 0.5s)			Indicator has 3 kinds of display status and during blinking, ON 0.5s and OFF 0.5s				
		Operation	Cool	Heating	Yellow	Red			Green
Malfunction of complete units current detection	U5		Off 3S and blink 13 times					During cooling and drying operation, compressor will stop while indoor fan will operate. During heating operation, the complete unit will stop operation.	There's circuit malfunction on outdoor units control panel AP1, please replace the outdoor units control panel AP1.
The four-way valve is abnormal	U7		Off 3S and blink 20 times					If this malfunction occurs during heating operation, the complete unit will stop operation.	1. Supply voltage is lower than AC175V; 2. Wiring terminal 4V is loosened or broken; 3. 4V is damaged, please replace 4V.
Zero crossing malfunction of outdoor unit	U9		Off 3S and blink 18 times					During cooling and drying operation, compressor will stop while indoor fan will operate. During heating operation, the complete unit will stop operation.	Replace outdoor control panel AP1
Frequency limiting (power)	L3					Off 3S and blink 13 times			
Compressor is open-circuited	L9				Off 1S and blink once				
The temperature for turning on the unit is reached	LP					Off 1S and blink 8 times			

Fault Displays

Models NEO09HP230V1AS & NEO12HP230V1AS

Malfunction Name	Indoor Unit			Outdoor Unit			A/C Status	Possible Causes	
	Dual-8 Code Display	Indicator Display (during blinking, ON 0.5s and OFF 0.5s)			Indicator has 3 kinds of display status and during blinking, ON 0.5s and OFF 0.5s				
		Operation	Cool	Heating	Yellow	Red			Green
Frequency limiting (module temperature)	LC					Off 1S and blink 11 times			
Normal communication							Off 0.5S and blink once		
Defrosting				Off 3S and blink once (during blinking, ON 10S and Off 0.5S)	Off 3S and blink twice			Defrosting will occur in heating mode, Compressor will operate while indoor fan will stop operation	It's the normal state

Fault Displays

Models NEO18HP230V1AS & NEO24HP230V1AS

Malfunction Name	Indoor Unit Displaying Method			Outdoor Unit Display (LED)				A/C Status	Malfunctions	
	Dual-8 Code Display	Indicator Display (during blinking, ON 0.5s and OFF 0.5s)			Indicator has 3 kinds of display status and during blinking, ON 0.5s and OFF 0.5s					
		Running LED	Cooling LED	Heating LED	D40/D5	D41/D6	D42/D16			D43/D30
System high pressure protection	E1	OFF 3S and blink once			□	☆	☆	☆	Cooling dehumidifying expect the indoor fan motor is running, others will stop to run. Heating all stop running	1. Refrigerant is too much; 2. Poor heating exchanging for units (including heat exchanger is dirty and unit heating radiating ambient is poor); Ambient temp is too high
Anti-freezing protection	E2	OFF 3S and blink twice			■	□	■	□	Cooling dehumidifying compressor outdoor fan motor will stop running, indoor fan motor will keep running	1. Poor indoor unit air returning; 2. Indoor fan motor rotating speed abnormal; 3. Evaporator is dirty
Compressor air exhaust high temp. protection	E4	OFF 3S and blink 4 times			■	□	■	☆	Cooling dehumidifying expect the indoor fan motor is running, others will stop to run. Heating all stop running	Please refer to trouble shoot (air exhaust protection, overload)
AC overload protection	E5	OFF 3S and blink 5 times			□	■	☆	□	Cooling dehumidifying expect the indoor fan motor is running, others will stop to run. Heating all stop running	1. Power supply is stable, fluctuation is too much; 2. Power supply is too low, overload is too much

Fault Displays

Models NEO18HP230V1AS & NEO24HP230V1AS

Malfunction Name	Indoor Unit Displaying Method				Outdoor Unit Display (LED)				A/C Status	Malfunctions
	Dual-8 Code Display	Indicator Display (during blinking, ON 0.5s and OFF 0.5s)			Indicator has 3 kinds of display status and during blinking, ON 0.5s and OFF 0.5s					
		Running LED	Cooling LED	Heating LED	D40/D5	D41/D6	D42/D16	D43/D30		
Indoor and outdoor units communication malfunction	E6	OFF 3S and blink 6 times			□	□	□	☆	Cooling compressor will stop, indoor fan motor works; Heating all will stop	Please refer to troubleshooting
Anti-high temp. protection	E8	OFF 3S and blink 8 times			■	□	■	■	Cooling compressor will stop, indoor fan motor works; Heating all will stop	Please refer to troubleshooting
Indoor unit motor no feedback	H6	OFF 3S and blink 11 times							Whole unit will stop to run	1. Poor insert for GPF; 2. Indoor control board AP1 malfunction; 3. Indoor motor M1 malfunction
Jump wire cap malfunction protection	C5	OFF 3S and blink 15 times							Whole unit will stop to run	Indoor control board AP1 jump cap poor connected, please reinsert or replace the jump cap
Indoor ambient sensor open circuit, short circuit	F1		OFF 3S and blink once						Cooling dehumidifying; indoor fan motor is running other overloads will stop. Heating whole unit will stop to run	1. Room temp sensor is not connected with the control panel AP1. 2. Room temp sensor is damaged

Fault Displays

Models NEO18HP230V1AS & NEO24HP230V1AS

Malfunction Name	Indoor Unit Displaying Method			Outdoor Unit Display (LED)				A/C Status	Malfunctions	
	Dual-8 Code Display	Indicator Display (during blinking, ON 0.5s and OFF 0.5s)			Indicator has 3 kinds of display status and during blinking, ON 0.5s and OFF 0.5s					
		Running LED	Cooling LED	Heating LED	D40/D5	D41/D6	D42/D16			D43/D30
Indoor evaporator sensor circuit open, short circuit	F2		OFF 3s and blink twice					Cooling, dehumidifying, except the indoor fan motor is running, others will stop to run. Heating; all stop running.	1. Room temperature sensor hasn't been connected well with indoor units control panel AP1 (refer to the wiring diagram for indoor unit), 2. Room temperature sensor is damaged (please refer to the resistance table of temperature sensor)	
Outdoor ambient sensor circuit open, circuit short	F3		OFF 3s and blink 3 times		□	□	☆	■	Cooling, dehumidifying, except the indoor fan motor is running, others will stop to run. Heating; all stop running.	1. Room temperature sensor hasn't been connected well with indoor units control panel AP1 (refer to the wiring diagram for indoor unit) 2. Room temperature sensor is damaged (please refer to the resistance table of temperature sensor)

Fault Displays

Models NEO18HP230V1AS & NEO24HP230V1AS

Malfunction Name	Indoor Unit Displaying Method			Outdoor Unit Display (LED)				A/C Status	Malfunctions	
	Dual-8 Code Display	Indicator Display (during blinking, ON 0.5s and OFF 0.5s)			Indicator has 3 kinds of display status and during blinking, ON 0.5s and OFF 0.5s					
		Running LED	Cooling LED	Heating LED	D40/D5	D41/D6	D42/D16			D43/D30
Outdoor condenser sensor open circuit, short circuit	F4		OFF 3s and blink 4 times		□	□	☆	□	Cooling, dehumidifying, except the indoor fan motor is running, others will stop to run. Heating; all stop running.	Outdoor temperature sensor hasn't been connected well or is damaged. Please check it by referring to the resistance table for the temperature sensor.
Outdoor air exhaust sensor open circuit, short circuit	F5		OFF 3s and blink 5 times		□	□	☆	□	During cooling and drying operating, compressor stops while indoor fan operates; During heating operation, the complete unit will stop operation	Outdoor temperature sensor hasn't been connected well or is damaged. Please check it by referring to the resistance table for the temperature sensor.

Fault Displays

Models NEO18HP230V1AS & NEO24HP230V1AS

Malfunction Name	Indoor Unit Displaying Method				Outdoor Unit Display (LED)				A/C Status	Malfunctions
	Dual-8 Code Display	Indicator Display (during blinking, ON 0.5s and OFF 0.5s)			Indicator has 3 kinds of display status and during blinking, ON 0.5s and OFF 0.5s					
		Running LED	Cooling LED	Heating LED	D40/D5	D41/D6	D42/D16	D43/D30		
Overload limit/descending frequency	F6		OFF 3S and blink 6 times		■	□	☆	☆	Overload normal operation, compressor is running, frequency descending	Please refer to troubleshooting
Over current need frequency descending	F8		OFF 3S and blink 8 times		■	■	□	■	Overload normal operation, compressor is running, frequency descending	1. Input power supply is too low; 2. System voltage is too high, over is too much
Air exhaust over high need frequency descending	F9		OFF 3S and blink 9 times		■	■	□	□	Overload normal operation, compressor is running, frequency descending	1. Overload is too much, ambient temp is too high; 2. Refrigerant is short; 3. Electric expansion malfunction
DC bus-bar voltage is too high	PH		OFF 3S and blink 11 times		□	■	□	☆	Cooling dehumidifying compressor stop running, Fan motor works; Heating all will stop	1. Testing wire terminal L and N position. If higher than 265VAC, please cut off the power supply and restart until back to normal; 2. If input voltage is normal, testing the voltage of electrolytic capacitor on AP1 after turn on the unit. There may be some problem and replace the AP1 if the electrolytic capacitor voltage range at 200-280V

Fault Displays

Models NEO18HP230V1AS & NEO24HP230V1AS

Malfunction Name	Indoor Unit Displaying Method			Outdoor Unit Display (LED)				A/C Status	Malfunctions	
	Dual-8 Code Display	Indicator Display (during blinking, ON 0.5s and OFF 0.5s)			Indicator has 3 kinds of display status and during blinking, ON 0.5s and OFF 0.5s					
		Running LED	Cooling LED	Heating LED	D40/D5	D41/D6	D42/D16			D43/D30
Whole unit's current testing malfunction	U9		OFF 3S and blink 13 times		□	■	☆	■	Cooling dehumidifying compressor stop running, Fan motor works; Heating all will stop	The circuit on AP1 has malfunction, replace the outdoor unit AP1
Compressor current overcurrent protection	P5		OFF 3S and blink 15 times		□	☆	□	□	Cooling dehumidifying compressor stop running, Fan motor works; Heating all will stop	Please refer to troubleshooting
Defrosting	H1			OFF 3S and blink once					Under the heating mode, compressor running, indoor/outdoor fan motor stop working	It is normal function
Electrostatic dedusting protection	H2			OFF 3S and blink 2times						
Compressor overload protection	H3			OFF 3S and blink 3 times	□	☆	☆	□	Cooling dehumidifying compressor stop running, Fan motor works; Heating all will stop	1. Wire terminal OVC-COMP loosen or circuit has problem, the resistance of SAT should be lower than 1 ohm; 2. Please refer to troubleshooting (exhaust/overload protection)

Fault Displays

Models NEO18HP230V1AS & NEO24HP230V1AS

Malfunction Name	Indoor Unit Displaying Method			Outdoor Unit Display (LED)				A/C Status	Malfunctions	
	Dual-8 Code Display	Indicator Display (during blinking, ON 0.5s and OFF 0.5s)			Indicator has 3 kinds of display status and during blinking, ON 0.5s and OFF 0.5s					
		Running LED	Cooling LED	Heating LED	D40/D5	D41/D6	D42/D16			D43/D30
System abnormal	H4			OFF 3S and blink 4 times					Cooling dehumidifying compressor stop running, Fan motor works; Heating all will stop	Please refer to troubleshooting
IPM protection	H5			OFF 3S and blink times	■	□	■	■	Cooling dehumidifying compressor stop running, Fan motor works; Heating all will stop	Please refer to troubleshooting
PFC protection	HC			OFF 3S and blink 6 times	□	■	☆	☆		
Compressor lose steps	H7			OFF 3S and blink 7 times	□	☆	■	☆		
Heating, anti-high temp declines	H0			OFF 3S and blink 10 times	■	□	★	☆		
Startups fail	Lc			OFF 3S and blink 11 times	□	☆	□	☆		
Compressor current testing circuit malfunction	U1			OFF 3S and blink 13 times	□	☆	■	□		
EEPROM malfunction	EE			OFF 3S and blink 15 times	□	□	□	■		
Capacitor charge malfunction	PU			OFF 3S and blink 17 times	□	■	□	■		

Fault Displays

Models NEO18HP230V1AS & NEO24HP230V1AS

Malfunction Name	Indoor Unit Displaying Method				Outdoor Unit Display (LED)				A/C Status	Malfunctions
	Dual-8 Code Display	Indicator Display (during blinking, ON 0.5s and OFF 0.5s)			Indicator has 3 kinds of display status and during blinking, ON 0.5s and OFF 0.5s					
		Running LED	Cooling LED	Heating LED	D40/D5	D41/D6	D42/D16	D43/D30		
Module sensor circuit diagram	P7			OFF 3S and blink 18 times	□	□	■			
Module temp over high protection	P8			OFF 3S and blink 19 times	■	□	☆	■		
DC Bus voltage dips	U3			OFF 3S and blink 20 times	□	■	■	■		
Low DC Bus voltage protection	PL			OFF 3S and blink 21 times	□	■	■	□		
IPM temp is too high limit/decrease frequency	EU				■	■	■	☆		
Four-way valve abnormal	U7				■	□	☆	□		
Outdoor unit zero-cross detecting error	U9				■	■	☆	□		
Anti-freezing limit/decrease frequency	FH				■	■	■	□	All loads work normally but the running frequency limited or decrease	
Fan mode protection	L3				■	□	□	□	Cooling: outdoor fan motor, compressor stop running; indoor fan works. Heating: outdoor fan, compressor, indoor fan motor stop running.	
									1. The wire terminal of outdoor fan motor is loose, repair connection 2. Motor damaged, replace the motor. 3. Fan motor module on mainboard is defective, replace the main board API	

Fault Displays

Models NEO30HP230V1AS & NEO36HP230V1AS

Malfunction Name	Indoor Unit			Outdoor Unit			A/C Status	Possible Causes	
	Dual-8 Code Display	Indicator Display (during blinking, ON 0.5s and OFF 0.5s)			Indicator has 3 kinds of display status and during blinking, ON 0.5s and OFF 0.5s				
		Operation	Cool	Heating	Yellow	Red			Green
High pressure protection of system	E1	OFF 3S and blink once						During cooling and drying operation, except indoor fan operates, all loads stop operation. During heating operation, the complete unit stops	Possible reasons: 1. Refrigerant was superabundant; 2. Poor heat exchange (including filth blockage of heat exchanger and bad radiating environment); Ambient temperature is too high
Antifreezing protection	E2	OFF 3S and blink twice			Off 3S and blink 3 times			During cooling and drying operation, compressor and outdoor fan stop while indoor fan operates	1. Poor air-return in indoor unit; 2. Fan speed is abnormal; 3. Evaporator is dirty
System block or refrigerant leakage	E3	Off 3S and blink 3 times				Off 3S and blink 9 times		The Dual-8 Code Display will show E3 until the low pressure switch stop operation	1. Low-pressure protection; 2. Low-pressure protection of system; 3. Low-pressure protection of compressor
High discharge temperature protection of compressor	E4	Off 3S and blink 4 times			Off 3S and blink 7 times			During cooling and drying operation, compressor and outdoor fan stop while indoor fan operates. During heating operation, all loads stop.	Please refer to the malfunction analysis (discharge protection, overload)
Overcurrent protection	E5	Off 3S and blink 5 times			Off 3S and blink 5 times			During cooling and drying operation, compressor and outdoor fan stop while indoor fan operates. During heating operation, all loads stop.	1. Supply voltage is unstable; 2. Supply voltage is too low and load is too high; 3. Evaporator is dirty

Fault Displays

Models NEO30HP230V1AS & NEO36HP230V1AS

Malfunction Name	Indoor Unit			Outdoor Unit			A/C Status	Possible Causes	
	Dual-8 Code Display	Indicator Display (during blinking, ON 0.5s and OFF 0.5s)			Indicator has 3 kinds of display status and during blinking, ON 0.5s and OFF 0.5s				
		Operation	Cool	Heating	Yellow	Red			Green
Communication Malfunction	E6	Off 3S and blink 6 times					OFF	Refer to the malfunction analysis	
High temperature resistant protection	H4	Off 3S and blink 11 times		Off 3S and blink 4 times	Off 3S and blink 6 times			Refer to the malfunction analysis	
EEPROM malfunction	EE	Off 3S and blink 15 times		Off 3S and blink 15 times	Off 3S and blink 11 times			Replace outdoor control panel AP1	
Limit/decrease frequency due to high temperature of module	EU		Off 3S and blink 6 times	Off 3S and blink 6 times				All load operate normally, while operation frequency for compressor is decreased Discharging after the complete unit is de-energized for 20 mins check on whether the thermal grease on IPM Module of outdoor control panel AP1 is sufficient and whether the radiator is inserted tightly. If its no use, please replace control panel AP1.	

Fault Displays

Models NEO30HP230V1AS & NEO36HP230V1AS

Malfunction Name	Indoor Unit			Outdoor Unit			A/C Status	Possible Causes	
	Dual-8 Code Display	Indicator Display (during blinking, ON 0.5s and OFF 0.5s)			Indicator has 3 kinds of display status and during blinking, ON 0.5s and OFF 0.5s				
		Operation	Cool	Heating	Yellow	Red			Green
Malfunction protection of jumper cap	C5	Off 3S and blink 15 times						Wireless remote receiver and button are effective, but can not dispose the related command	1. No jumper cap insert on mainboard; 2. Incorrect insert of jumper cap; 3. Jumper cap damaged; 4. Abnormal detecting circuit of mainboard
Gathering refrigerant	F0	Off 3S and blink 1 times	Off 3S and blink 1 times					When the outdoor unit receives signal of gathering refrigerant, the system will be forced to run under cooling mode for gathering refrigerant	Nominal cooling mode
Indoor ambient temperature sensor is open/short circuited	F1		Off 3S and blink 1 times					During cooling and drying operating, compressor stops while indoor fan operates; During heating operation, the complete unit will stop operation.	1. Loosening or bad contact of indoor evaporator temp sensor and mainboard terminal; 2. Components on the mainboard fall; 3. Indoor evaporator temp sensor damaged; 4. Mainboard damaged.
Indoor evaporator temperature sensor is open/short circuited	F2		Off 3S and blink twice					AC stops operation once reaches the setting temperature. Cooling, drying: internal fan motor stops operation while other loads stop operation; heating: AC stop operation	1. Loosening or bad contact of indoor evaporator temp sensor and mainboard terminal; 2. Components on the mainboard fall; 3. Indoor evaporator temp sensor damaged; 4. Mainboard damaged.

Fault Displays

Models NEO30HP230V1AS & NEO36HP230V1AS

Malfunction Name	Indoor Unit			Outdoor Unit			A/C Status	Possible Causes	
	Dual-8 Code Display	Indicator Display (during blinking, ON 0.5s and OFF 0.5s)			Indicator has 3 kinds of display status and during blinking, ON 0.5s and OFF 0.5s				
		Operation	Cool	Heating	Yellow	Red			Green
Outdoor ambient temperature sensor is open/short circuited	F3		Off 3S and blink 3 times				Off 3S and blink 6 times	During cooling and drying operating, compressor stops while indoor fan operates; During heating operation, the complete unit will stop operation.	Outdoor temperature sensor hasn't been connected well or is damaged. Please check it by referring to the resistance table for temperature sensor.
Outdoor condenser temperature sensor is open/short circuited	F4		Off 3S and blink 4 times				Off 3S and blink 5 times	During cooling and drying operating, compressor stops while indoor fan operates; During heating operation, the complete unit will stop operation.	Outdoor temperature sensor hasn't been connected well or is damaged. Please check it by referring to the resistance table for temperature sensor.
Outdoor discharge temperature sensor is open/short circuited	F5		Off 3S and blink 5 times				Off 3S and blink 7 times	During cooling and drying operation, compressor will stop after operating for about 3 mins, while indoor fan will operate. During heating operation, the complete unit will stop after operating for about 3 mins.	1. Outdoor temperature sensor hasn't been connected well or is damaged. Please check it by referring to the resistance table for temperature sensor; 2. The head of temperature sensor hasn't been inserted into the copper tube.
Limit/decrease frequency due to overload	F6		Off 3S and blink 6 times				Off 3S and blink 3 times	All loads operate normally, while operation frequency for compressor is decreased.	Refer to the malfunction analysis (overload, high temperature resistant)

Fault Displays

Models NEO30HP230V1AS & NEO36HP230V1AS

Malfunction Name	Indoor Unit				Outdoor Unit			A/C Status	Possible Causes
	Dual-8 Code Display	Indicator Display (during blinking, ON 0.5s and OFF 0.5s)			Indicator has 3 kinds of display status and during blinking, ON 0.5s and OFF 0.5s				
		Operation	Cool	Heating	Yellow	Red	Green		
Decrease frequency due to overcurrent	F8		Off 3S and blink 8 times			Off 3S and blink 1 times		During cooling and drying operation, compressor will stop while indoor fan will operate. During heating operation, the complete unit will stop operation.	The input supply voltage is too low; System pressure is too high and overload
Decrease frequency due to high air discharge	F9		Off 3S and blink 9 times			Off 3S and blink 2 times		All loads operate normally, while operation frequency for compressor is decreased.	Overload or temperature is too high; Refrigerant is insufficient; Malfunction of electric expansion valve (EKV)
Limit/decrease frequency due to anti freezing	FH		Off 3S and blink 2 times	Off 3S and blink 2 times		Off 3S and blink 4 times		All loads operate normally, while operation frequency for compressor is decreased.	Poor air-return in indoor unit or fan speed is too low
Voltage of DC bus-bar is too high	PH		Off 3S and blink 11 times		Off 3S and blink 13 times			During cooling and drying operation, compressor will stop while indoor fan will operate. During heating operation, the complete unit will stop operation.	1. Measure the voltage of position L and N on wiring board (XT), if the voltage is higher than 150VAC, turn on the unit after the supply voltage is increase to the normal range; 2. If the AC input is normal, measure the voltage of electrolytic capacitor C on control panel (AP1), if its normal, theres malfunction for the circuit, please replace the control panel (AP1)

Fault Displays

Models NEO30HP230V1AS & NEO36HP230V1AS

Malfunction Name	Indoor Unit			Outdoor Unit			A/C Status	Possible Causes	
	Dual-8 Code Display	Indicator Display (during blinking, ON 0.5s and OFF 0.5s)			Indicator has 3 kinds of display status and during blinking, ON 0.5s and OFF 0.5s				
		Operation	Cool	Heating	Yellow	Red			Green
Voltage of DC bus-bar is too low	PL			Off 3S and blink 21 times	Off 3S and blink 12 times			During cooling and drying operation, compressor will stop while indoor fan will operate. During heating operation, the complete unit will stop operation. 1. Measure the voltage of position L and N on wiring board (XT), if the voltage is higher than 150VAC, turn on the unit after the supply voltage is increase to the normal range; 2. If the AC input is normal, measure the voltage of electrolytic capacitor C on control panel (AP1), if its normal, theres malfunction for the circuit, please replace the control panel (AP1)	
Compressor Min frequency in test state	P0		blinking in cool mode,ON 0.25s and OFF 0.25s	blinking in heat mode,ON 0.25s and OFF 0.25s				Showing during min. cooling or min. heating test	
Compressor rated frequency in test state	P1		blinking in cool mode,ON 0.25s and OFF 0.25s	blinking in heat mode,ON 0.25s and OFF 0.25s				Showing during nominal cooling or nominal heating test	
Compressor maximum frequency in test state	P2		blinking in cool mode,ON 0.25s and OFF 0.25s	blinking in heat mode,ON 0.25s and OFF 0.25s				Showing during max. cooling or max. heating test	

Fault Displays

Models NEO30HP230V1AS & NEO36HP230V1AS

Malfunction Name	Indoor Unit			Outdoor Unit			A/C Status	Possible Causes	
	Dual-8 Code Display	Indicator Display (during blinking, ON 0.5s and OFF 0.5s)			Indicator has 3 kinds of display status and during blinking, ON 0.5s and OFF 0.5s				
		Operation	Cool	Heating	Yellow	Red			Green
Compressor intermediate frequency in test state	P3		blinking in cool mode, ON 0.25s and OFF 0.25s	blinking in heat mode, ON 0.25s and OFF 0.25s				Showing during middle cooling or middle heating test	
Overcurrent protection of phase current for compressor	P5		Off 3S and blink 15 times				During cooling and drying operation, compressor will stop while indoor fan will operate. During heating operation, the complete unit will stop operation.	Refer to malfunction analysis	
Charging malfunction of capacitor	PU			Off 3S and blink 17 times			During cooling and drying operation, compressor will stop while indoor fan will operate. During heating operation, the complete unit will stop operation.	Refer to the part three-charging malfunction analysis of capacitor	
Malfunction of module temperature sensor circuit	P7			Off 3S and blink 18 times			During cooling and drying operation, compressor will stop while indoor fan will operate. During heating operation, the complete unit will stop operation.	Replace outdoor control panel AP1	

Fault Displays

Models NEO30HP230V1AS & NEO36HP230V1AS

Malfunction Name	Indoor Unit			Outdoor Unit			A/C Status	Possible Causes	
	Dual-8 Code Display	Indicator Display (during blinking, ON 0.5s and OFF 0.5s)			Indicator has 3 kinds of display status and during blinking, ON 0.5s and OFF 0.5s				
		Operation	Cool	Heating	Yellow	Red			Green
Module high temperature protection	P8			Off 3S and blink 19 times				During cooling and drying operation, compressor will stop while indoor fan will operate. During heating operation, the complete unit will stop operation. After the complete unit is de-energized for 20 mins, check whether the thermal grease on the IPM Module of outdoor control panel AP1 is sufficient and whether the radiator is inserted tightly. If its no use, please replace control panel AP1	
Decrease frequency due to high temperature resistant during heating operation	H0			Off 3S and blink 10 times				All loads operate normally, while operation frequency for compressor is decreased. Refer to the malfunction analysis (overload, high temperature resistant)	
Static dedusting protection	H2			Off 3S and blink 2 times					
Overload protection of compressor	H3			Off 3S and blink 3 times	Off 3S and blink 8 times			During cooling and drying operation, compressor will stop while indoor fan will operate. During heating operation, the complete unit will stop operation. 1. Wiring terminal OVC-COMP is loosened. In normal state, the resistance for this terminal should be less than 1ohm; 2. Refer to the malfunction analysis.	

Fault Displays

Models NEO30HP230V1AS & NEO36HP230V1AS

Malfunction Name	Indoor Unit			Outdoor Unit			A/C Status	Possible Causes	
	Dual-8 Code Display	Indicator Display (during blinking, ON 0.5s and OFF 0.5s)			Indicator has 3 kinds of display status and during blinking, ON 0.5s and OFF 0.5s				
		Operation	Cool	Heating	Yellow	Red			Green
IPM protection	H5			Off 3S and blink 5 times	Off 3S and blink 4 times			During cooling and drying operation, compressor will stop while indoor fan will operate. During heating operation, the complete unit will stop operation.	Refer to the malfunction analysis (IPM protection, loss of synchronism protection, and overcurrent protection of phase current for compressor)
Module temperature is too high	H5			Off 3S and blink 5 times	Off 3S and blink 10 times				
Internal motor (fan motor) do not operate	H6	Off 3S and blink 11 times						Internal fan motor, external fan motor, compressor and electric heater stop operation, guide louver stops at present location	1. Bad contact of DC motor feedback terminal; 2. Bad contact of DC motor control end; 3. Fan motor is stalling; 4. Motor malfunction; 5. Malfunction of mainboard rev detecting circuit
Desynchronizing of compressor	H7			Off 3S and blink 7 times				During cooling and drying operation, compressor will stop while indoor fan will operate. During heating operation, the complete unit will stop operation.	Refer to the malfunction analysis (IPM protection, loss of synchronism protection, and overcurrent protection of phase current for compressor)
PFC protection	HC			Off 3S and blink 6 times	Off 3S and blink 14 times			During cooling and drying operation, compressor will stop while indoor fan will operate. During heating operation, the complete unit will stop operation.	Refer to the malfunction analysis

Fault Displays

Models NEO30HP230V1AS & NEO36HP230V1AS

Malfunction Name	Indoor Unit			Outdoor Unit			A/C Status	Possible Causes	
	Dual-8 Code Display	Indicator Display (during blinking, ON 0.5s and OFF 0.5s)			Indicator has 3 kinds of display status and during blinking, ON 0.5s and OFF 0.5s				
		Operation	Cool	Heating	Yellow	Red			Green
Outdoor DC fan motor malfunction	L3	Off 3S and blink 23 times				Off 3S and blink 14 times		Outdoor DC fan motor malfunction lead to compressor stop operation DC fan motor malfunction or system blocked or the connector loosed	
Power protection	L9	Off 3S and blink 20 times			Off 3S and blink 9 times			Compressor stop operation and Outdoor fan motor will stop 30s later, 3 minutes later fan motor and compressor will restart To protect the electronic components when detect high power	
Indoor unit and outdoor unit doesn't match	LP	Off 3S and blink 19 times			Off 3S and blink 16 times			Compressor and Outdoor fan motor can't work Indoor unit and outdoor unit doesn't match	
Failure start-up	LC			Off 3S and blink 11 times				During cooling and drying operation, compressor will stop while indoor fan will operate. During heating operation, the complete unit will stop operation. Refer to the malfunction analysis	
Malfunction of phase current detection circuit for compressor	U1			Off 3S and blink 13 times				During cooling and drying operation, compressor will stop while indoor fan will operate. During heating operation, the complete unit will stop operation. Replace outdoor control panel AP1	

Fault Displays

Models NEO30HP230V1AS & NEO36HP230V1AS

Malfunction Name	Indoor Unit			Outdoor Unit			A/C Status	Possible Causes	
	Dual-8 Code Display	Indicator Display (during blinking, ON 0.5s and OFF 0.5s)			Indicator has 3 kinds of display status and during blinking, ON 0.5s and OFF 0.5s				
		Operation	Cool	Heating	Yellow	Red			Green
Malfunction of voltage dropping for DC bus-bar	U3			Off 3S and blink 20 times				During cooling and drying operation, compressor will stop while indoor fan will operate. During heating operation, the complete unit will stop operation.	Supply voltage is unstable
Malfunction of complete units current detection	U5			Off 3S and blink 13 times				During cooling and drying operation, compressor will stop while indoor fan will operate. During heating operation, the complete unit will stop operation.	Theres circuit malfunction on outdoor units control panel AP1, please replace the outdoor units control panel AP1.
The four-way valve is abnormal	U7			Off 3S and blink 20 times				If this malfunction occurs during heating operation, the complete unit will stop operation.	1. Supply voltage is lower than AC175V; 2. Wiring terminal 4V is loosened or broken; 3. 4V is damaged, please replace 4V.
Zero crossing malfunction of outdoor unit	U9			Off 3S and blink 18 times				During cooling and drying operation, compressor will stop while indoor fan will operate. During heating operation, the complete unit will stop operation.	Replace outdoor control panel AP1
Frequency limiting (power)	L3					Off 3S and blink 13 times			

Fault Displays

Models NEO30HP230V1AS & NEO36HP230V1AS

Malfunction Name	Indoor Unit			Outdoor Unit			A/C Status	Possible Causes	
	Dual-8 Code Display	Indicator Display (during blinking, ON 0.5s and OFF 0.5s)			Indicator has 3 kinds of display status and during blinking, ON 0.5s and OFF 0.5s				
		Operation	Cool	Heating	Yellow	Red			Green
Compressor is open-circuited	L9				Off 3S and blink once				
The temperature for turning on the unit is reached	LP					Off 3S and blink 8 times			
Frequency limiting (module temperature)	LC					Off 3S and blink 11 times			
Normal communication							continuously		
Defrosting				Off 3S and blink once	Off 3S and blink twice			Defrosting will occur in heating mode, Compressor will operate while indoor fan will stop operation	
								It's the normal state	

Fault Displays

Models NEO30HP230V1AS & NEO36HP230V1AS

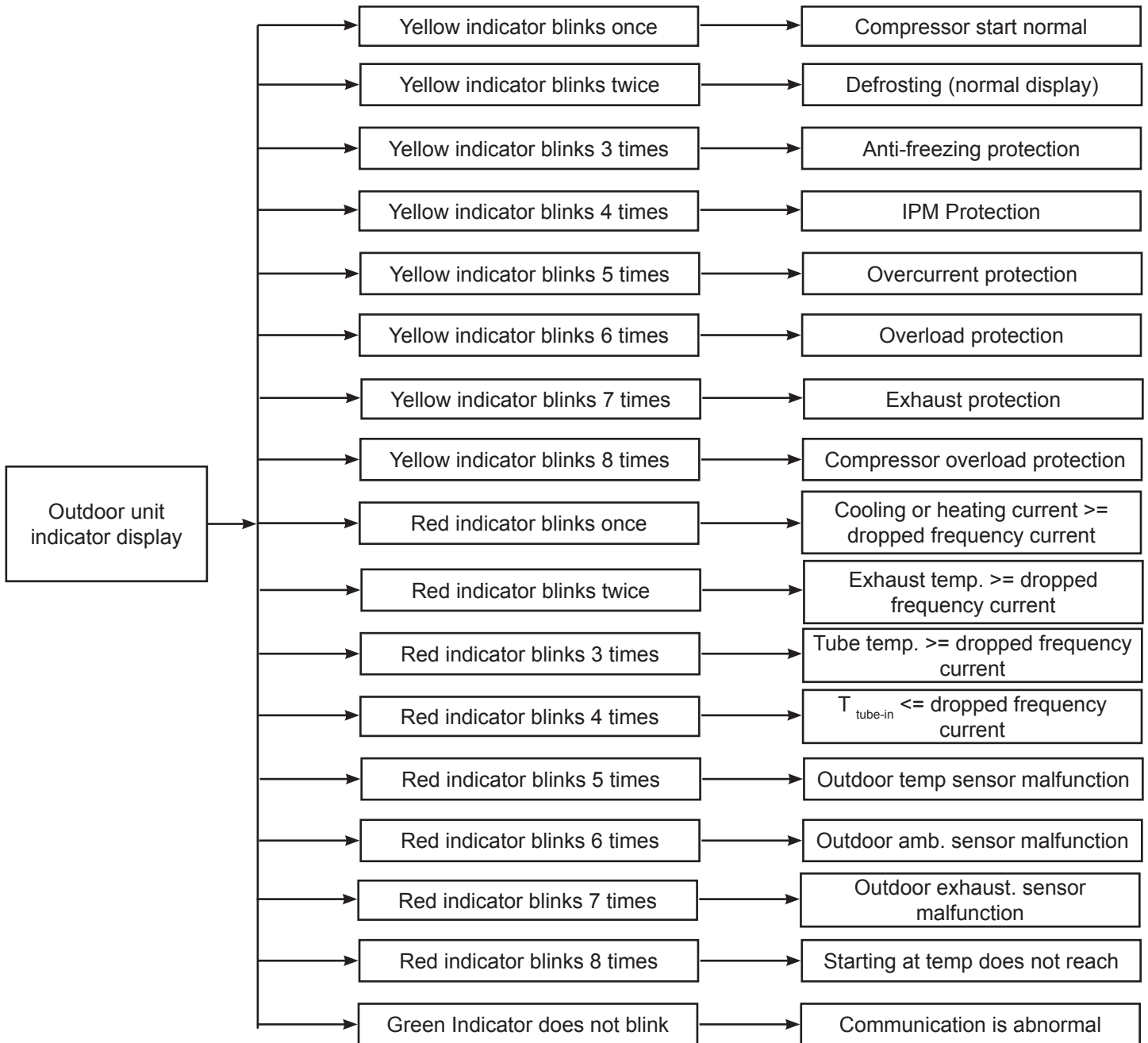

Fault Displays

Models NEO30HP230V1AS & NEO36HP230V1AS

Analysis or processing of some of the malfunction display:

1. Compressor discharge protection

Possible reasons: shortage of refrigerant; blockage of air filter; poor ventilation or air flow short pass for condenser; the system has non-condensing gas (such as air, water etc.); blockage of capillary assy (including filter); leakage inside four-way valve causes incorrect operation; malfunction of compressor; malfunction of protection relay; malfunction of discharge sensor; outdoor temperature too high. Processing method: refer to the malfunction analysis in the above section.

2. Low voltage overcurrent protection

Possible reason: Sudden drop of supply voltage.

3. Communication malfunction

Processing method: Check if communication signal cable is connected reliably.

4. Sensor open or short circuit

Processing method: Check for normal condition of sensor, connected with the corresponding position on the controller and if damage of lead wire is found.

5. Compressor over load protection

Possible reasons: insufficient or too much refrigerant; blockage of capillary and increase of suction temp.; improper running of compressor, burning in or stuck of bearing, damage of discharge valve; malfunction of protector. Processing method: adjust refrigerant amount; replace the capillary; replace the compressor; use universal meter to check if the contactor of compressor is fine when it is not over heated, if not replace the protector.

6. System malfunction

Overload protection. When tube temperature (Check the temperature of outdoor heat exchanger when cooling and check the temperature of indoor heat exchanger when heating) is too high, protection will be activated. Possible reasons: Outdoor temperature is too high when cooling; insufficient outdoor air circulation; refrigerant flow malfunction. Please refer to the malfunction analysis in the previous section for handling method.

7. IPM module protection

Processing method: Once the module malfunction happens, if it persists for a long time and can not be self-canceled, cut off the power and turn off the unit, and then re-energize the unit again after about 10 min. After repeating the procedure for several times, if the malfunction still exists, replace the module.

Troubleshooting

Capacitor Charging Fault

- Use AC voltmeter to check proper voltage on terminals “L” & “N” on the terminal board. Voltage should be within 10% of voltage on nameplate.
- Is the reactor (L) correctly connected? Check for damaged reactor.

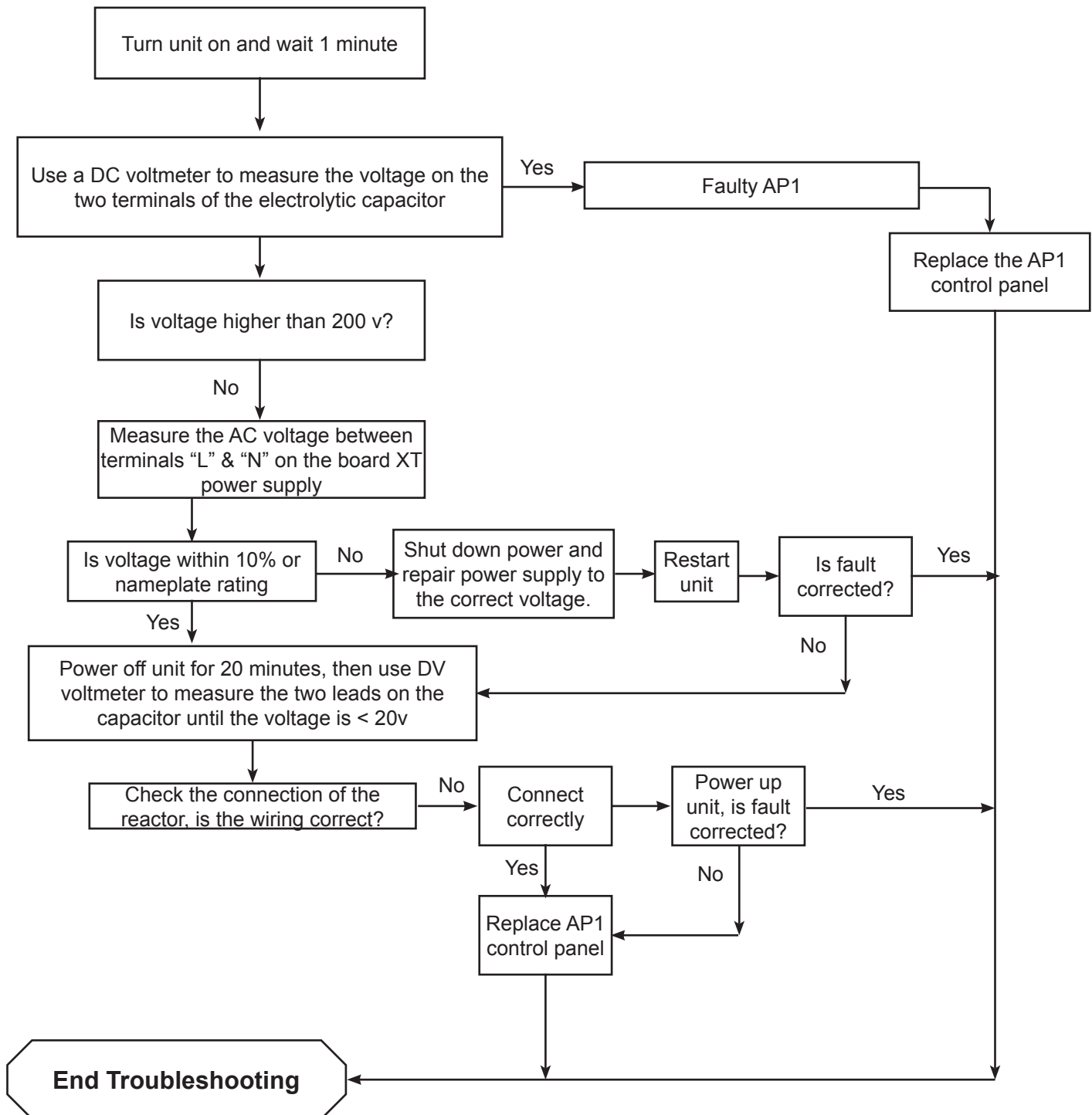

Troubleshooting

Unit Will Not Start

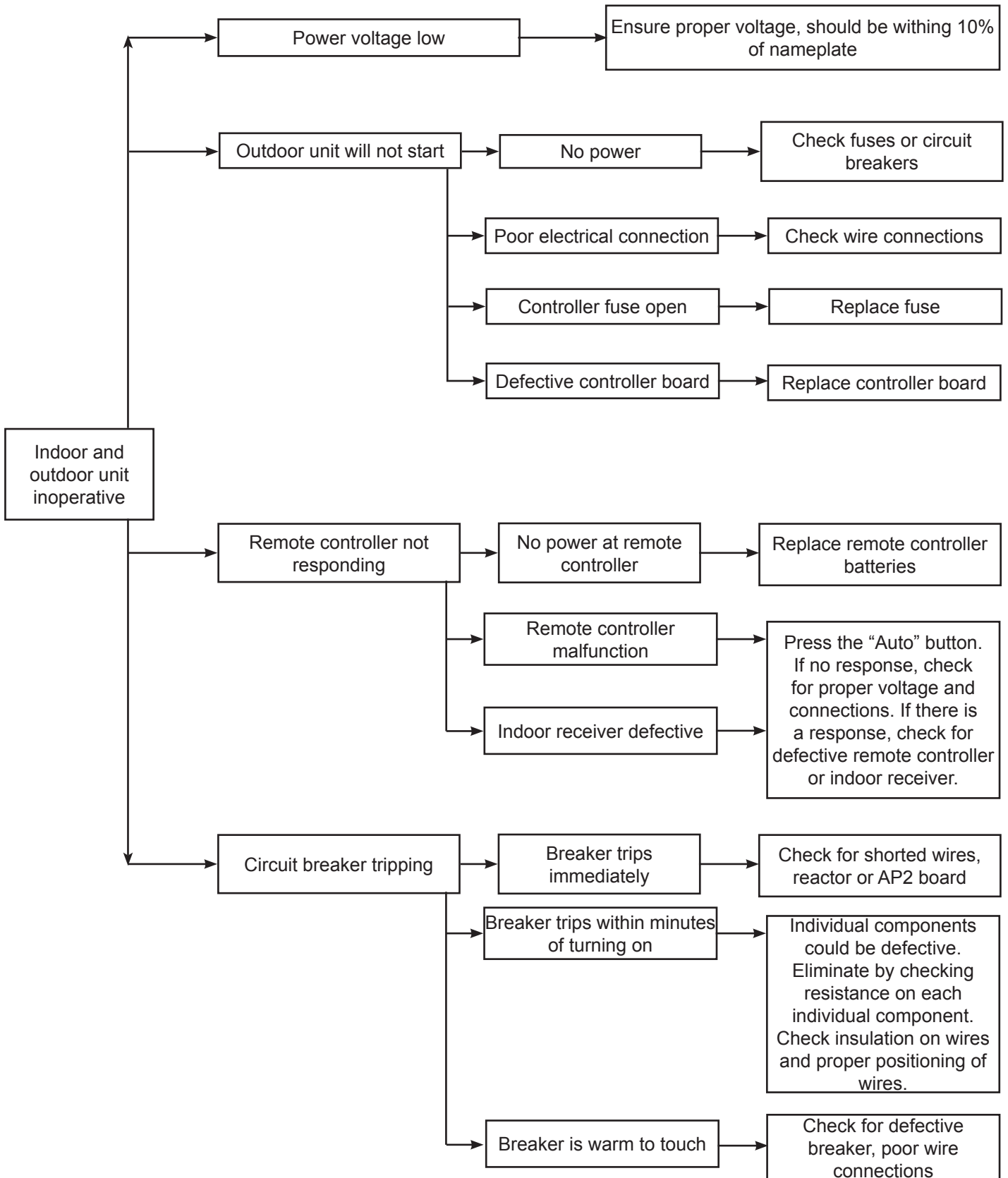

Troubleshooting

Inadequate Cooling or Heating

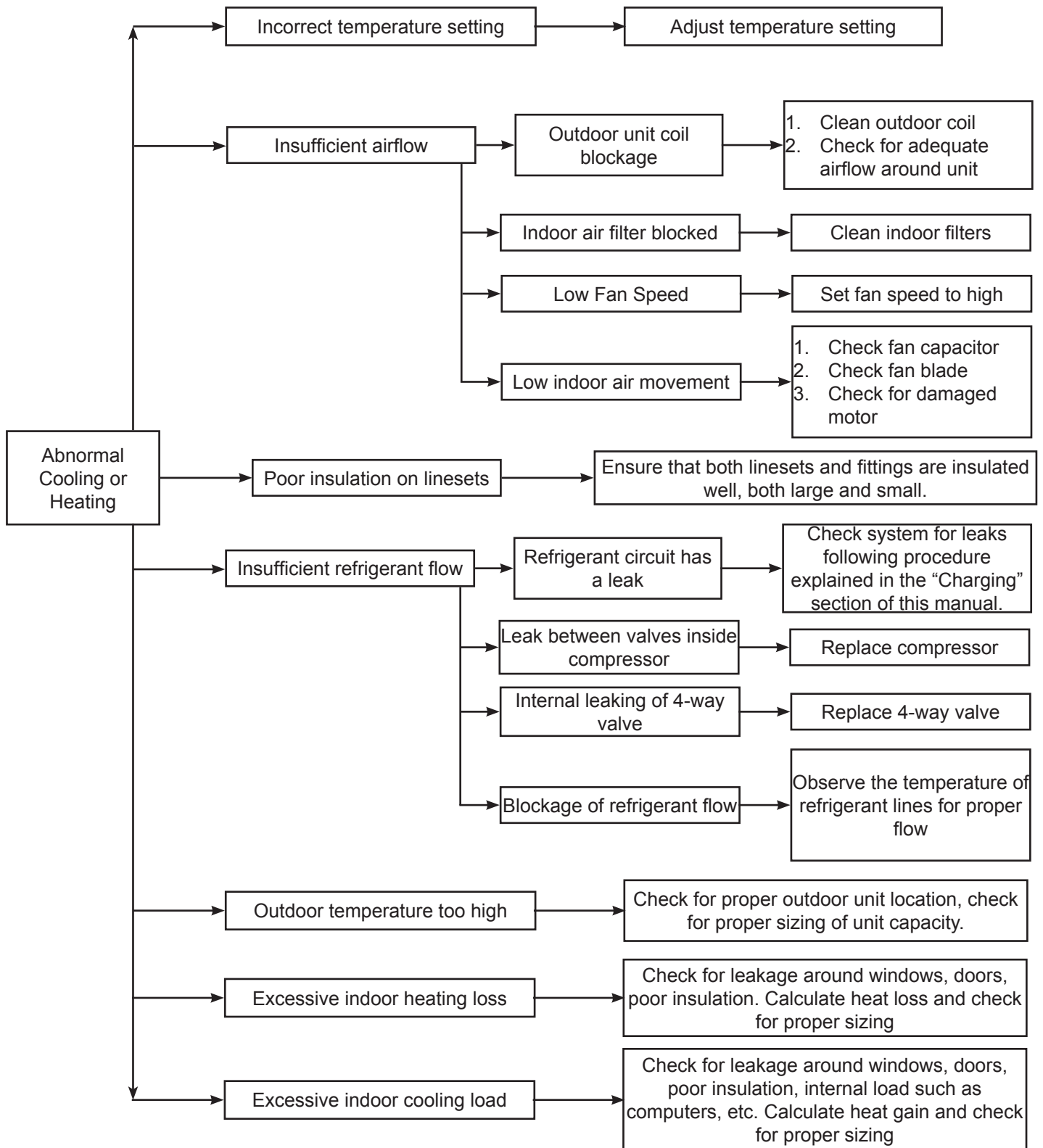

Troubleshooting

Anti-high temperature and overload malfunction

High Discharge Temperature Protection of Compressor.

Status:

Cooling operation, compressor stops while indoor fans runs. Heating operation, complete unit stops

1. Is unit running in proper outdoor ambient range
2. Faulty outdoor temperature sensor
3. Refrigerant leak
4. Poor airflow of outdoor unit
5. Follow Troubleshooting procedure

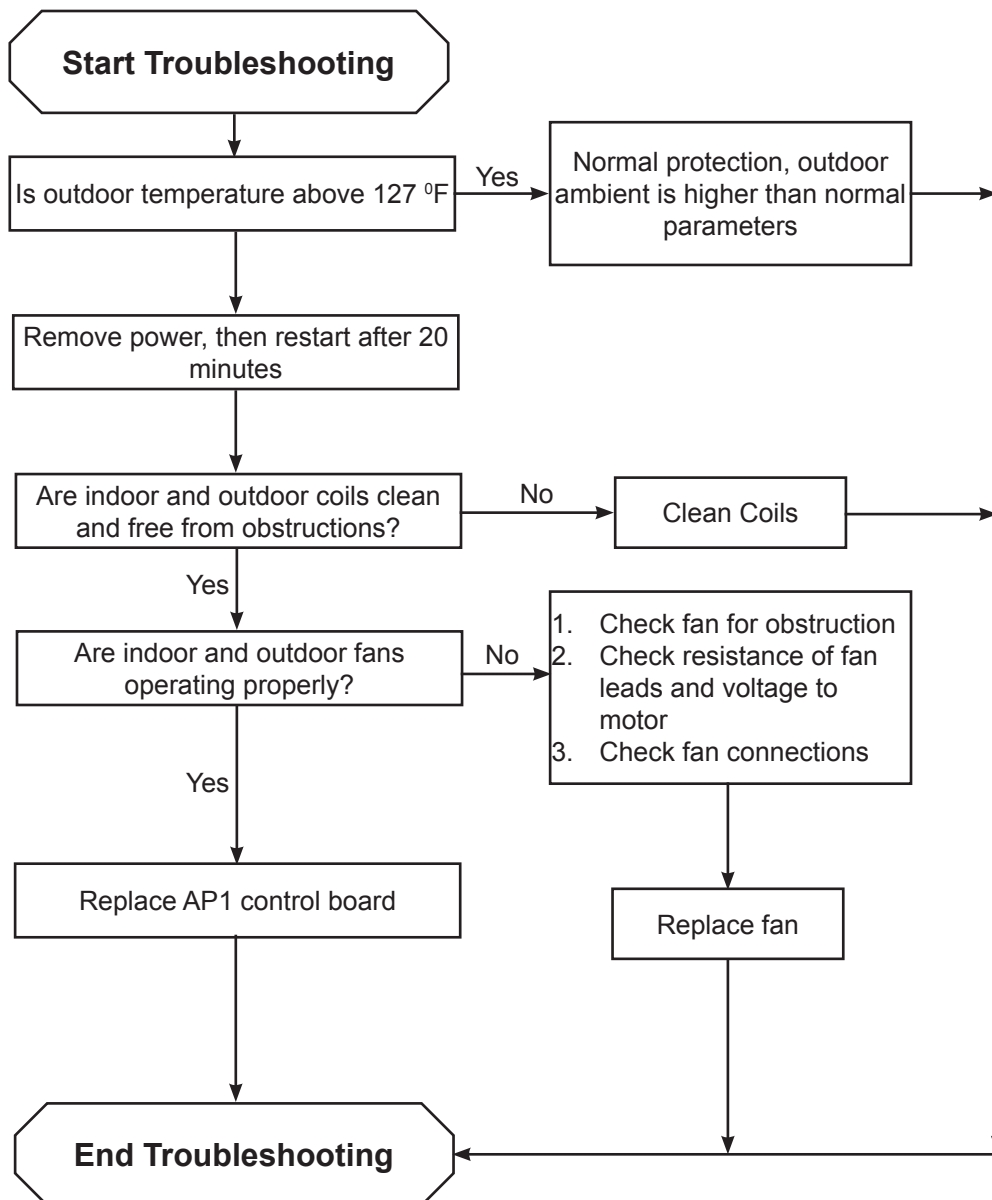

Outdoor Fan Connection

Troubleshooting

Start Failure Malfunction

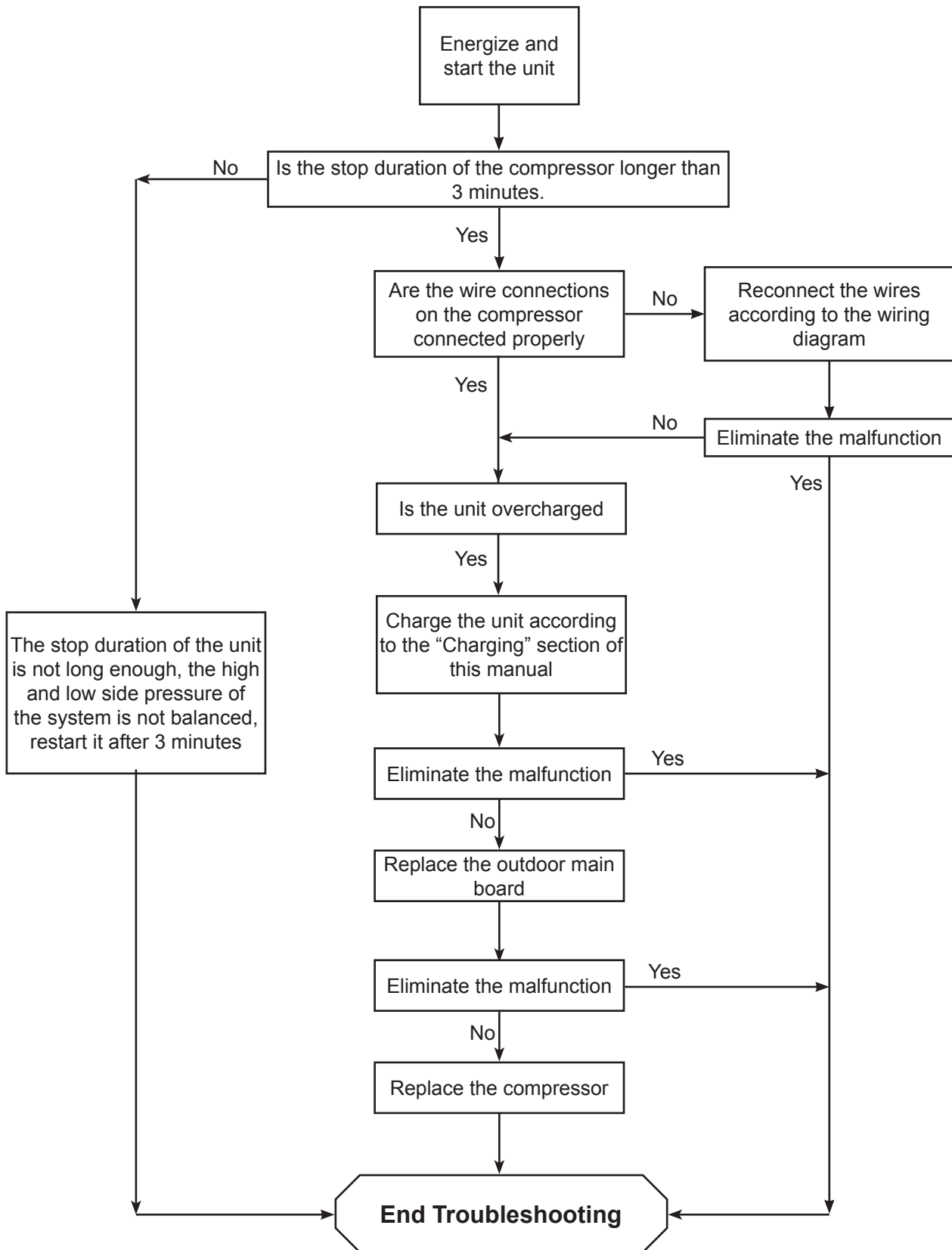

Troubleshooting

Miscellaneous Malfunctions

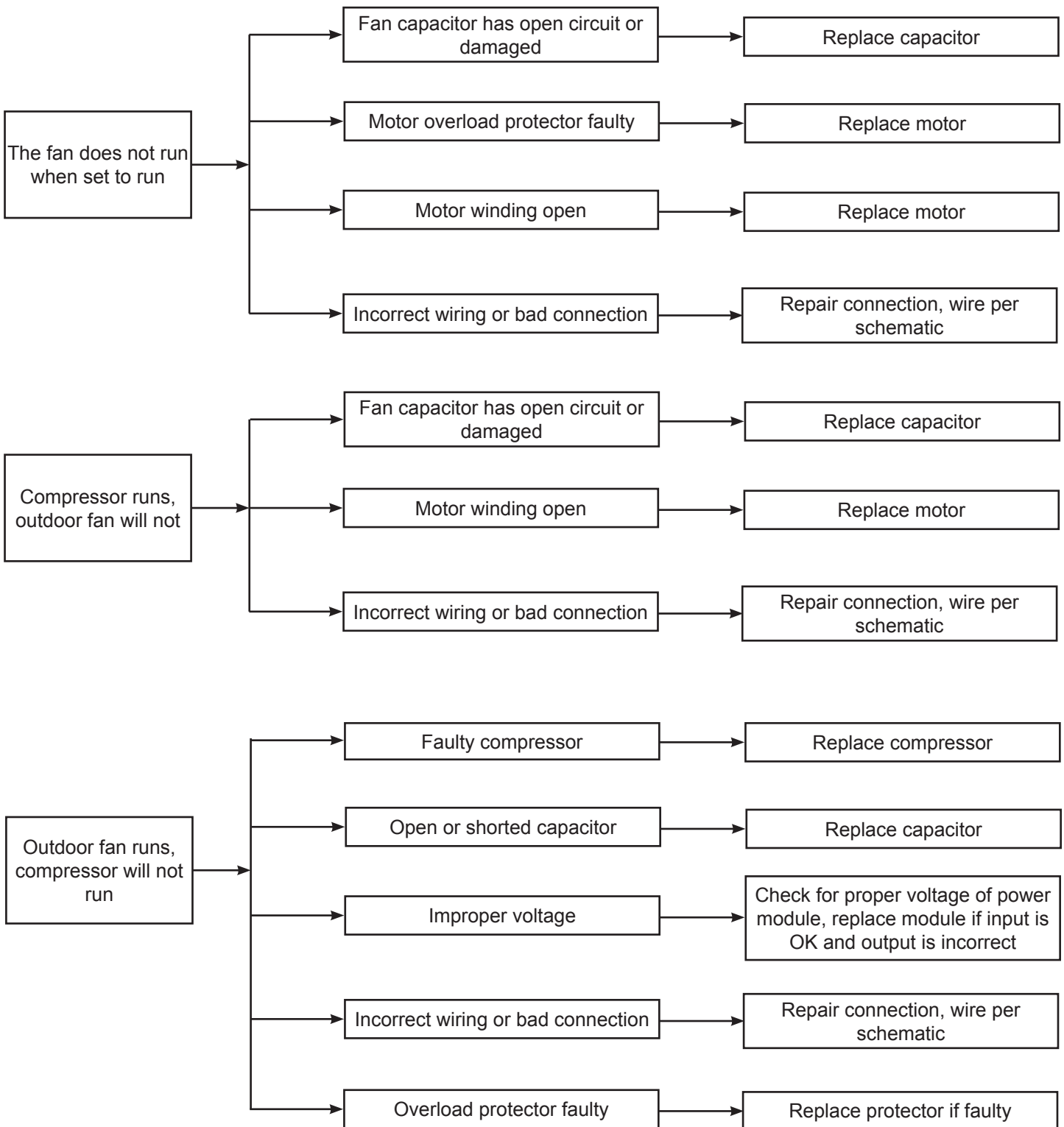

Troubleshooting

Miscellaneous Malfunctions, cont.

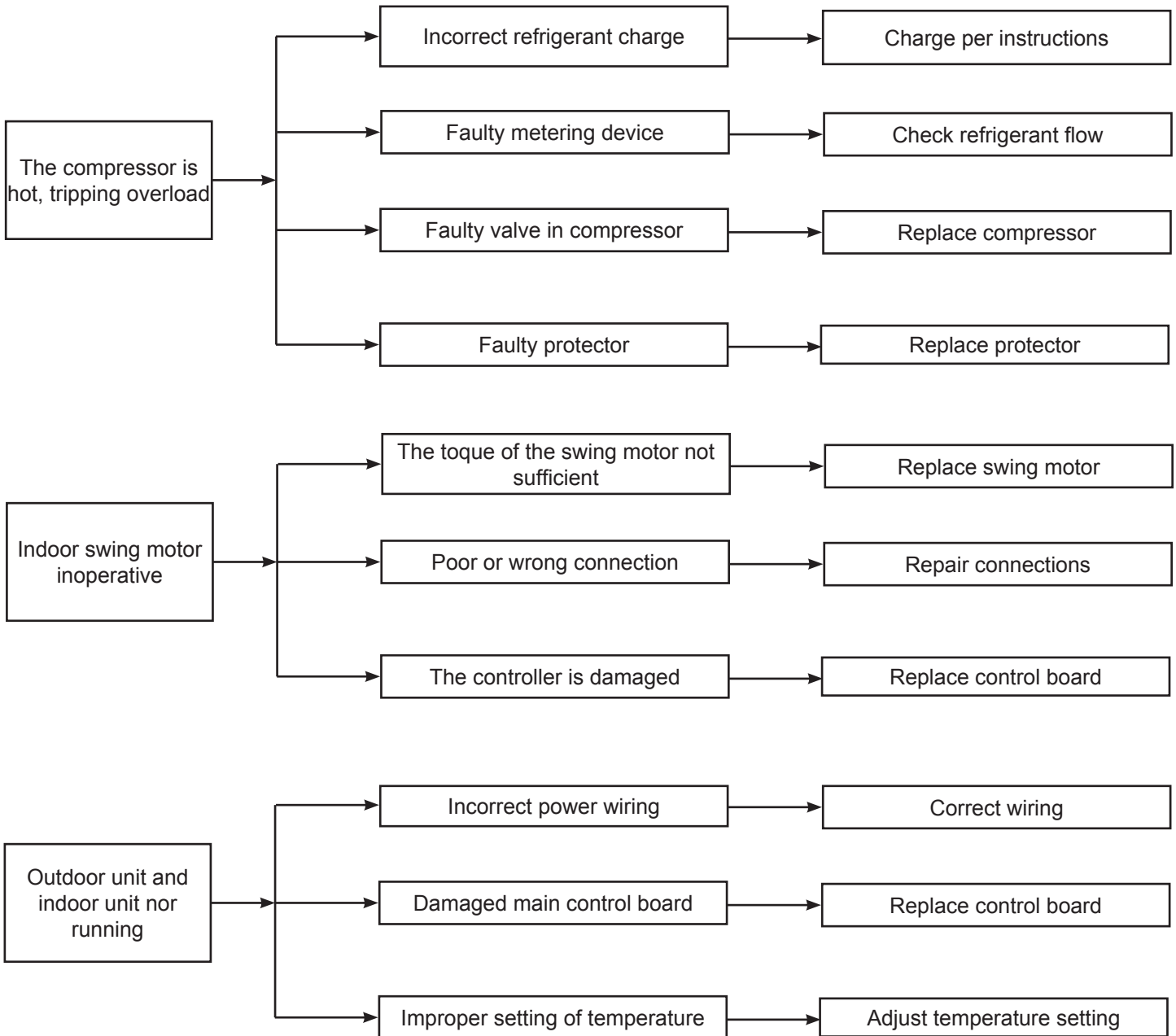

Troubleshooting

Miscellaneous Malfunctions, cont.

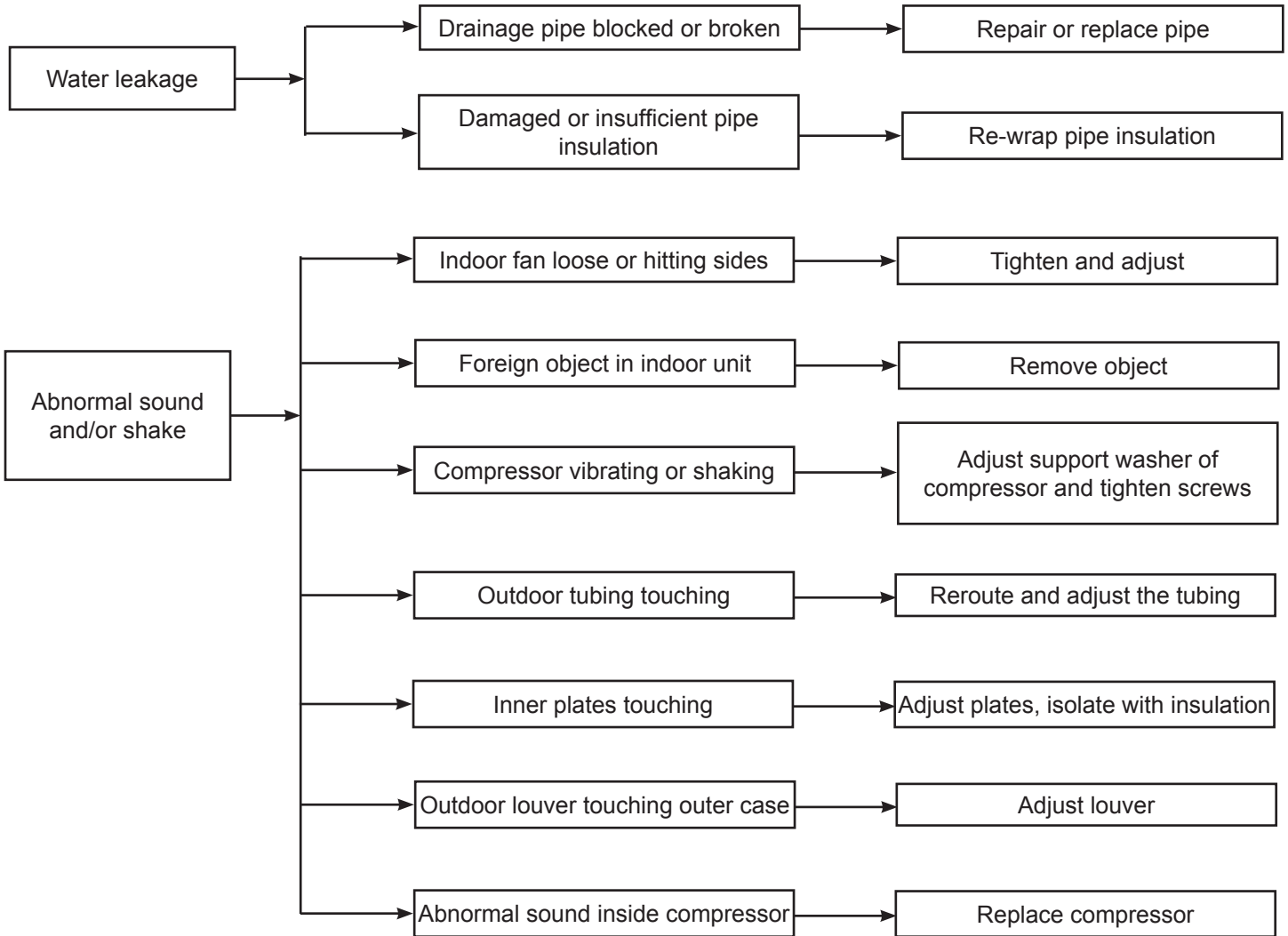

Troubleshooting

Compressor Running Hot

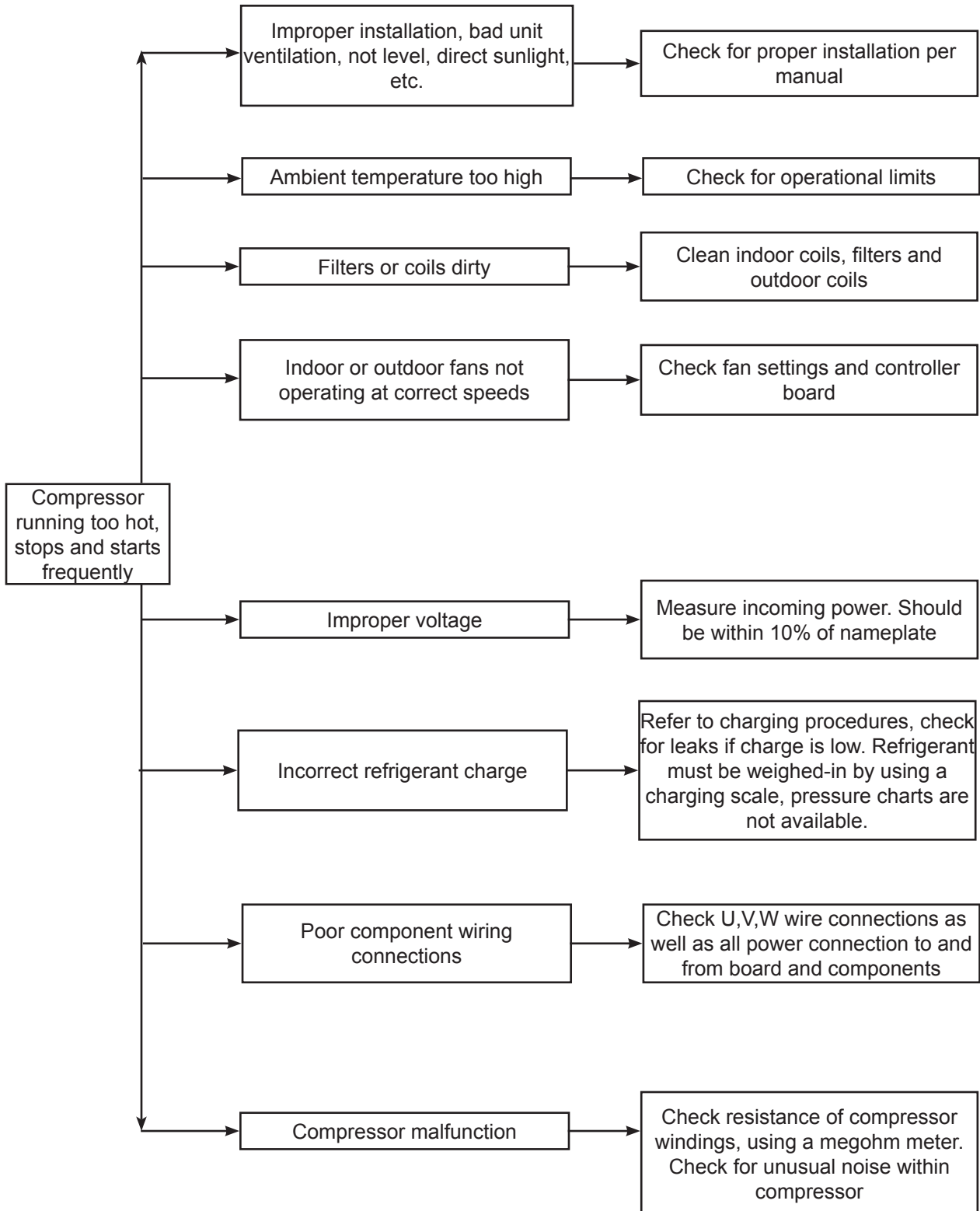

Troubleshooting

Compressor Overload, Discharge protection malfunction

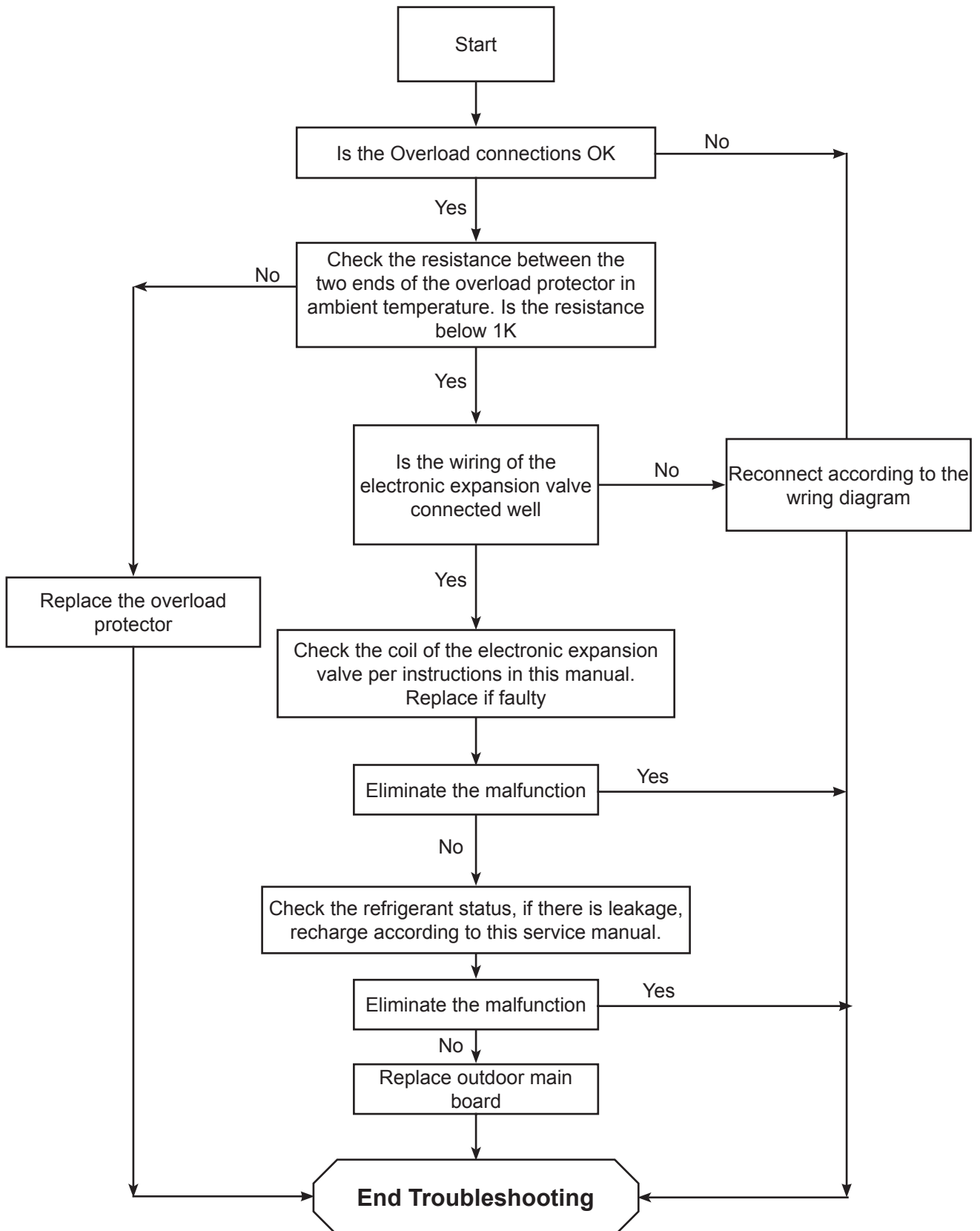

Troubleshooting

Compressor Desynchronizing Malfunction

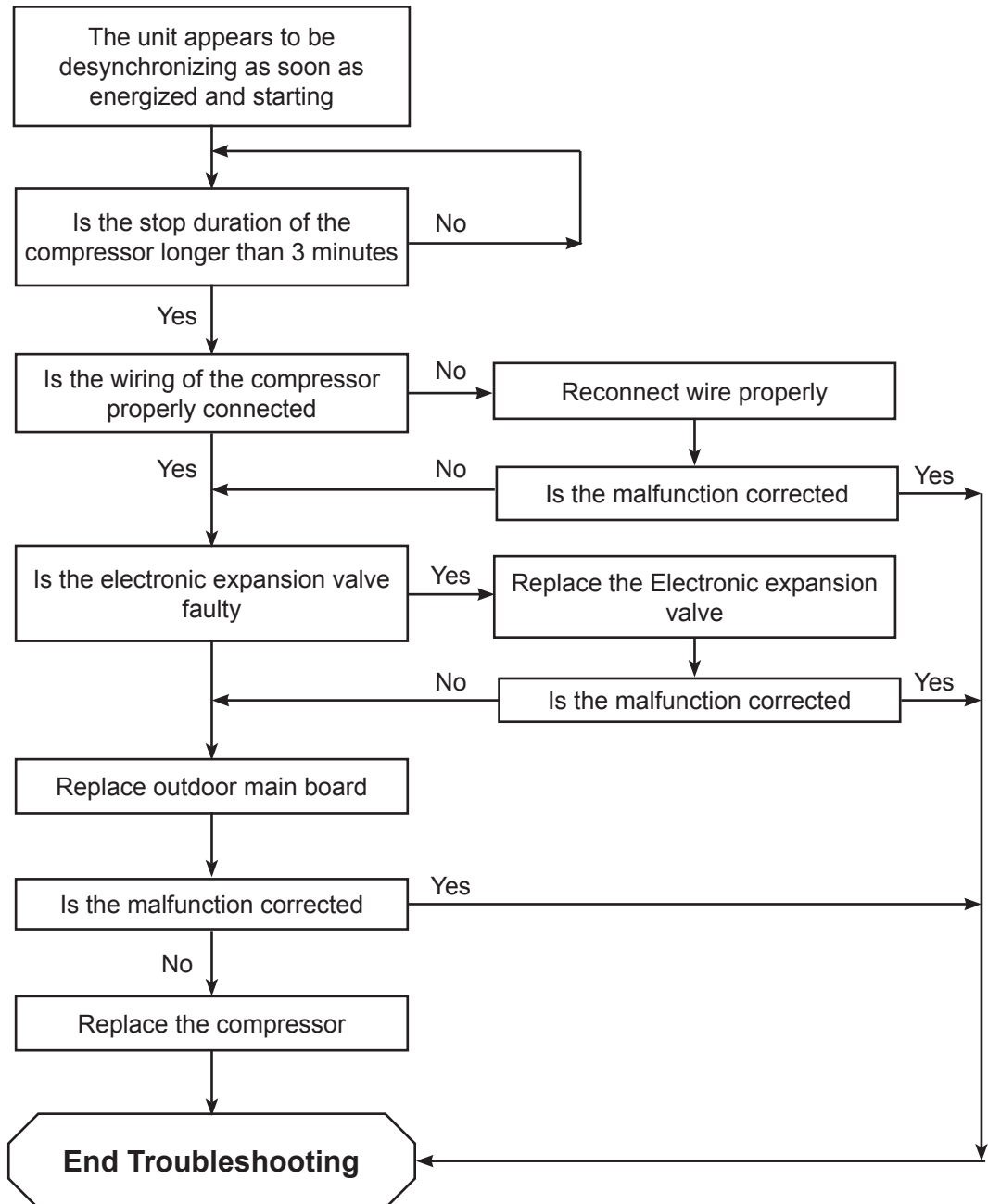

Troubleshooting

Compressor Desynchronizing Malfunction, cont.

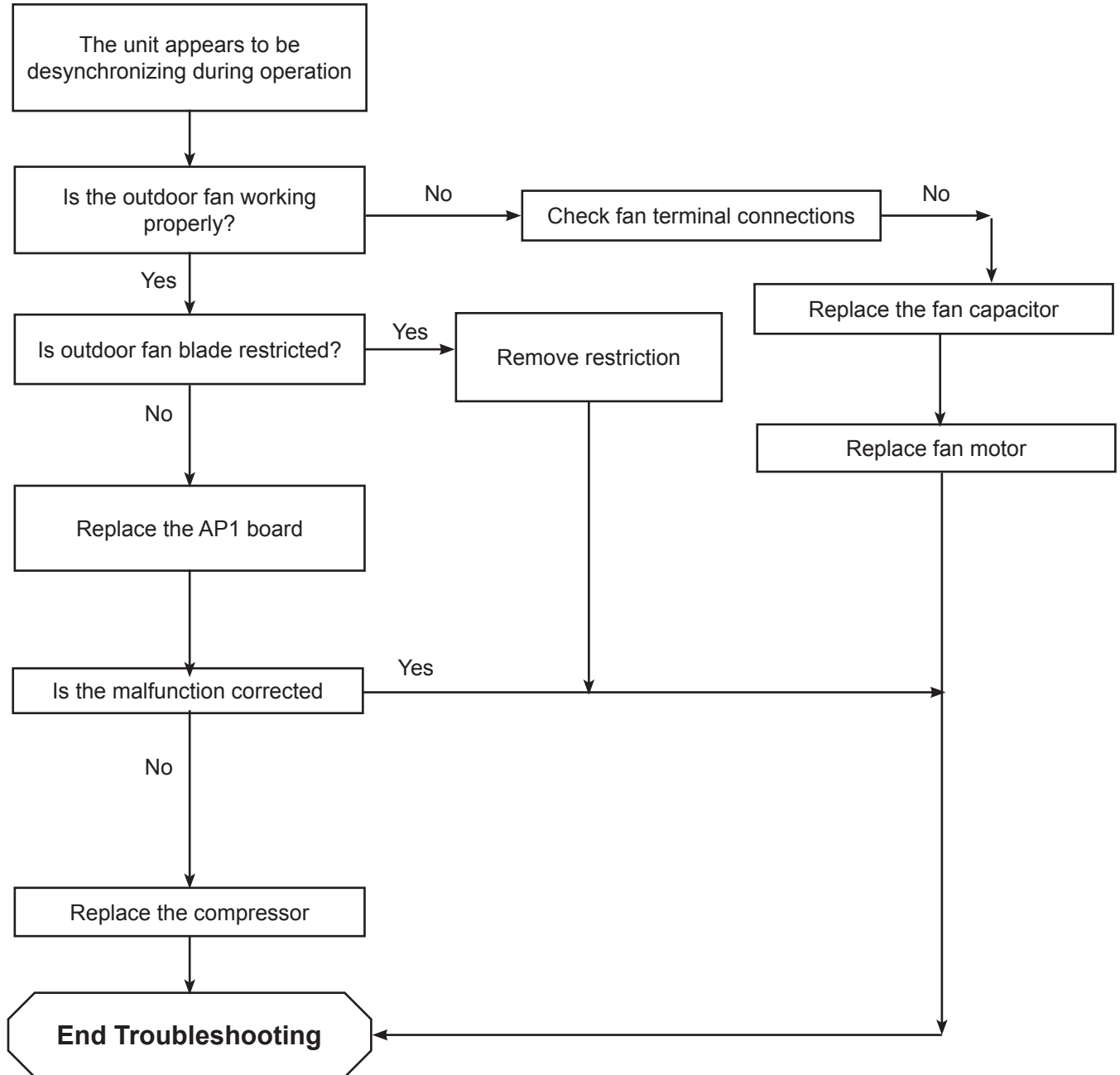

Error Code Diagnostics

C5 Error Code

C5



Jumper Cap Malfunction

Status:

Wireless remote will not send command to indoor unit.

1. No jumper cap inserted on board
2. Jumper cap not fully seated
3. Jumper cap damaged
4. Bad control board

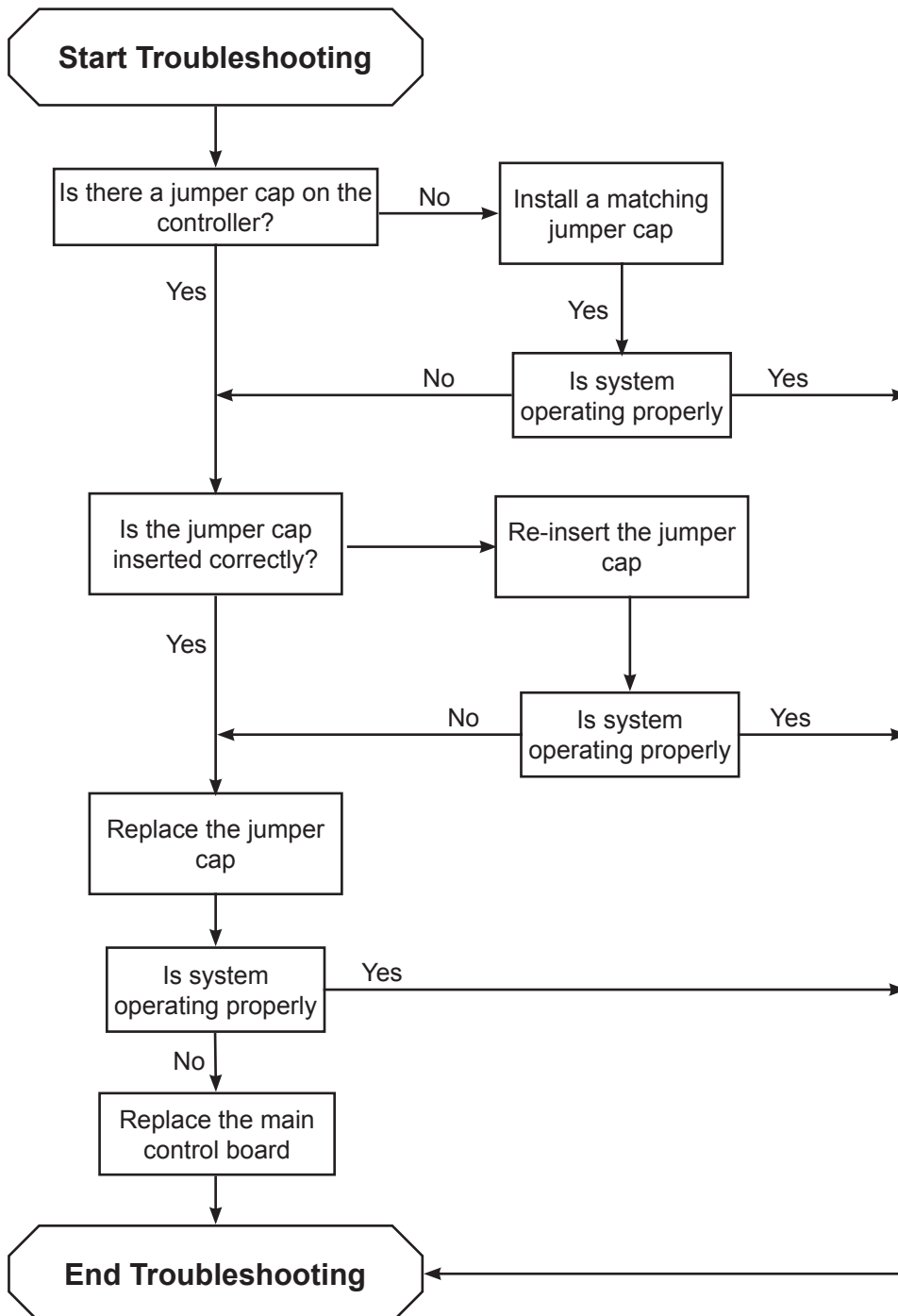

Error Code Diagnostics

EE, EU, FH, E2 Error Codes

Fault & Status

Possible Causes

EE



EEProm Malfunction

Status:

During cooling & dehumidifying, indoor unit operates while other functions stop; During heating operation, complete unit stops

1. Faulty outdoor control board, replace AP1

EU



Decrease in Frequency due to over heating of Module

Status:

All units operate with decrease in capacity

1. After the unit is off for 20 minutes, check for sufficient thermal grease on IPM module of the outdoor control board and that is seated tightly.
2. Faulty control board, replace

FH



Decrease frequency due to anti-freezing

Status:

All units operate with decrease in capacity

1. Poor air return in indoor unit
2. Fan speed too slow

E2



Antifreeze Protection

Status:

Cooling operation, compressor stops while indoor fans runs. Heating operation, complete unit stops

1. Poor air return in indoor unit
2. Fan speed abnormal
3. Indoor coil dirty

Error Code Diagnostics

E1 Error Codes

Compressor High Pressure Protection

E1



Fault & Status

High Pressure Protection of System

Status:

During cooling & dehumidifying, indoor unit operates while other functions stop; During heating operation, complete unit stops

Possible Causes

1. Refrigerant overcharge
2. Dirty outdoor coil
3. Blockage of airflow
4. Outdoor ambient too high

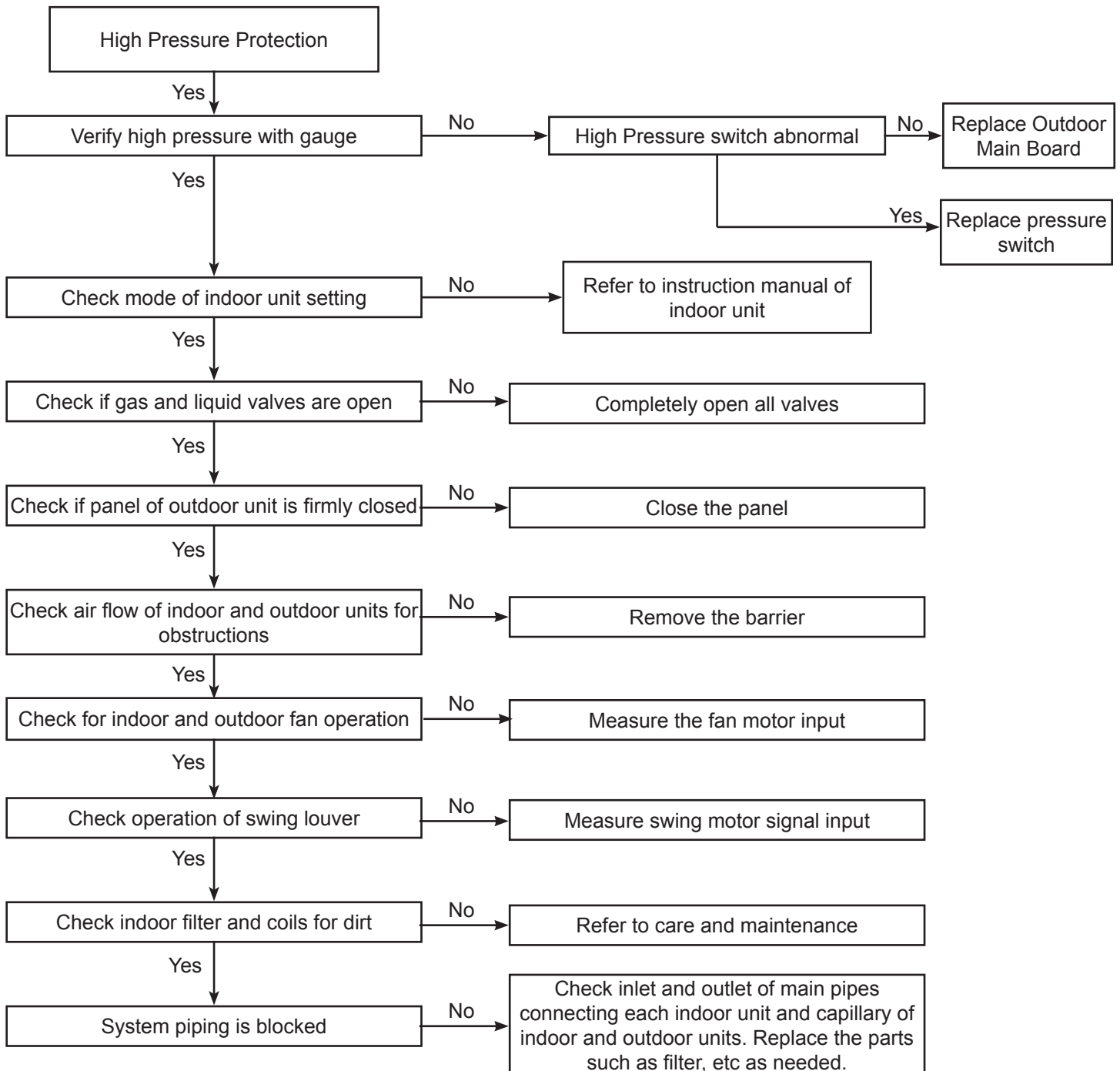

Error Code Diagnostics

E3 Error Codes

Compressor Low Pressure Protection

E3



Fault & Status

Low Pressure Protection

Status:

Cooling operation, compressor stops while indoor fans runs. Heating operation, complete unit stops

Possible Causes

1. Low refrigerant charge
2. Improper indoor mode setting
3. Improper fan operation
4. Refrigerant valve not fully opened

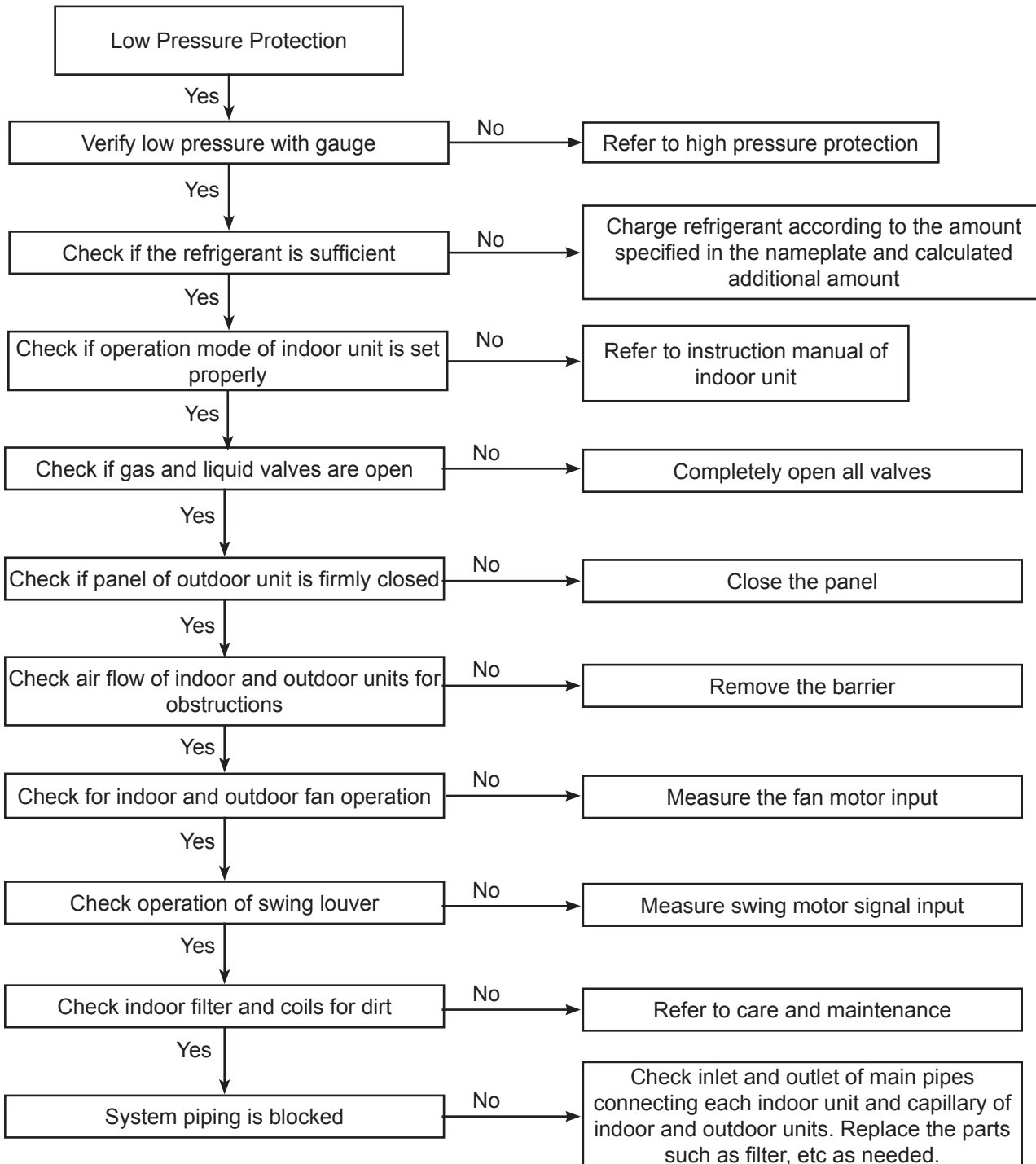

Error Code Diagnostics

E4 Error Code

High Discharge Temperature Protection of Compressor.

E4



High Discharge Temperature Protection of Compressor.

Status:

Cooling operation, compressor stops while indoor fans runs. Heating operation, complete unit stops

1. Faulty outdoor temperature sensor
2. Refrigerant leak
3. Poor airflow of outdoor unit
4. Follow Troubleshooting procedure

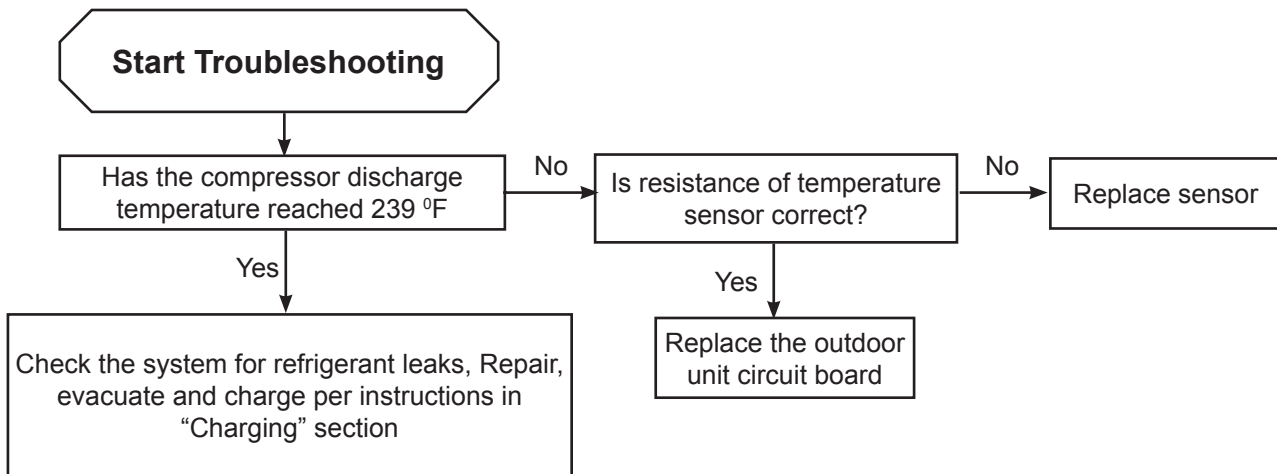

Error Code Diagnostics

E5 Error Code

Overcurrent Protection



E5

Fault & Status

Overcurrent Protection

Status:

During cooling & dehumidifying, indoor unit operates while other functions stop; During heating operation, complete unit stops

Possible Causes

1. Supply voltage is unstable
2. Supply voltage is too low
3. Coils are dirty
4. Improper refrigerant charge

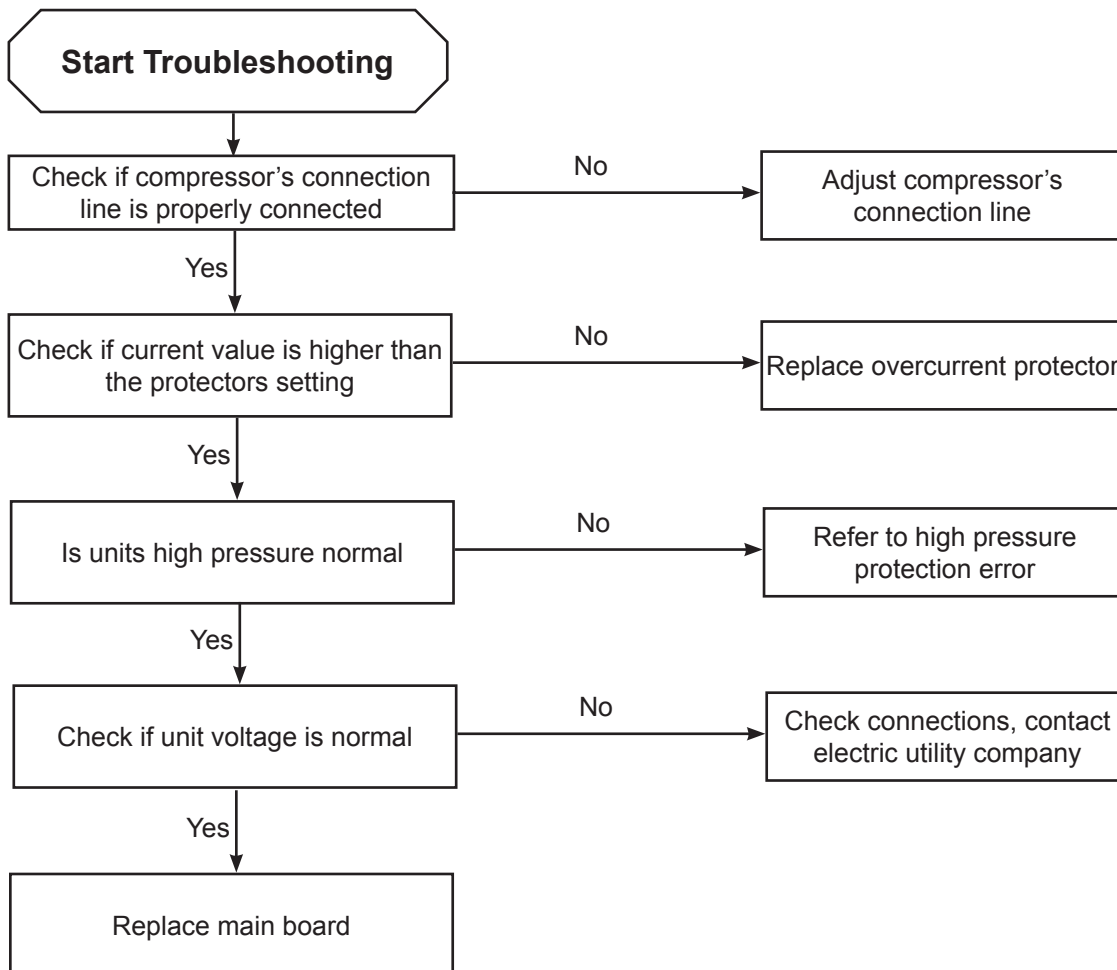

Error Code Diagnostics

E6 Error Code Communication Failure of Some Indoor Units

E6



Communication Failure

Status:

Cooling operation, compressor stops while indoor fans runs. Heating operation, complete unit stops

1. Improper voltages
2. Mis-matched indoor and outdoor units
3. Improper wiring between indoor and outdoor units

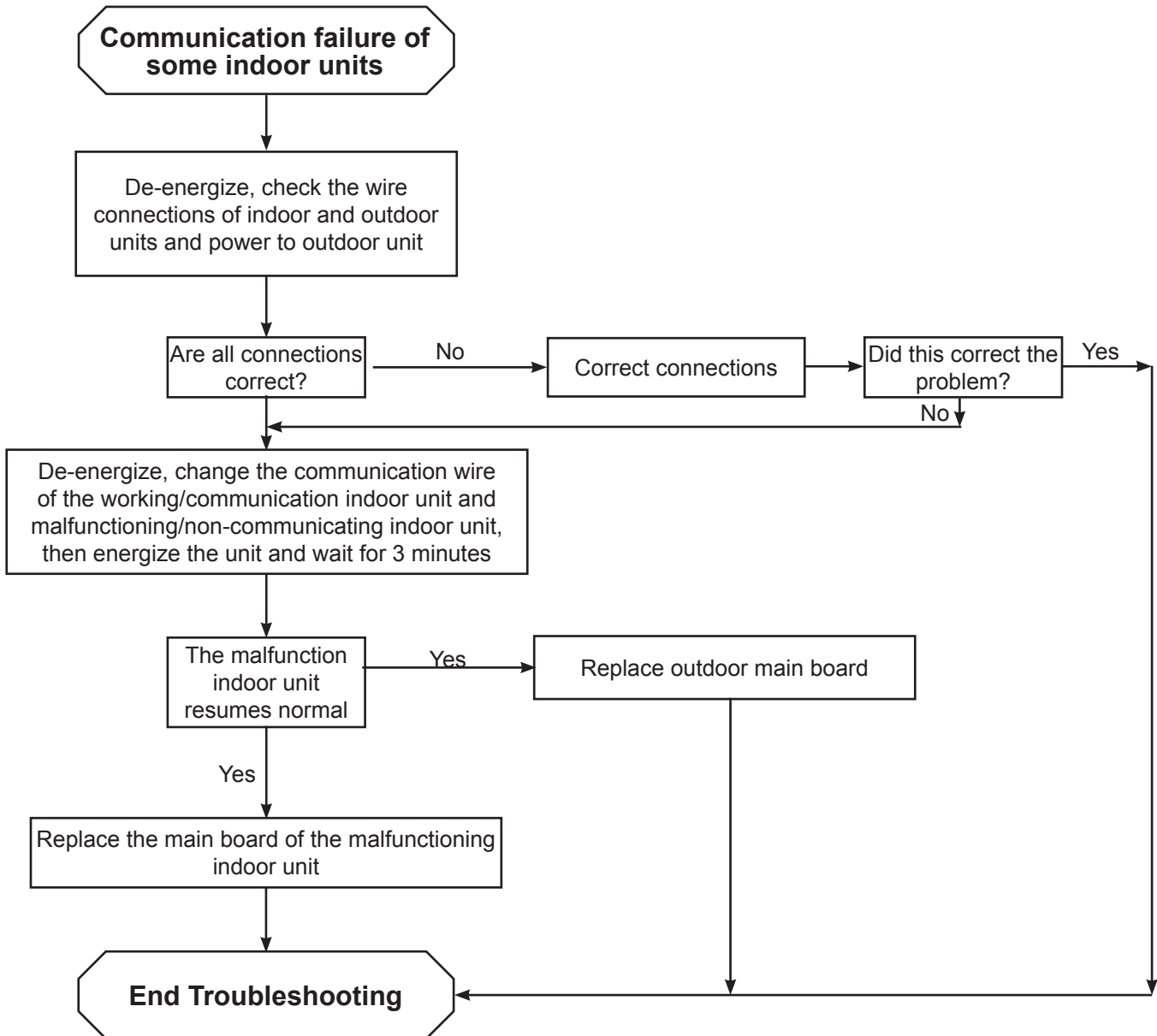

Error Code Diagnostics

E6 Error Code, continued

Communication Failure of All Indoor Units

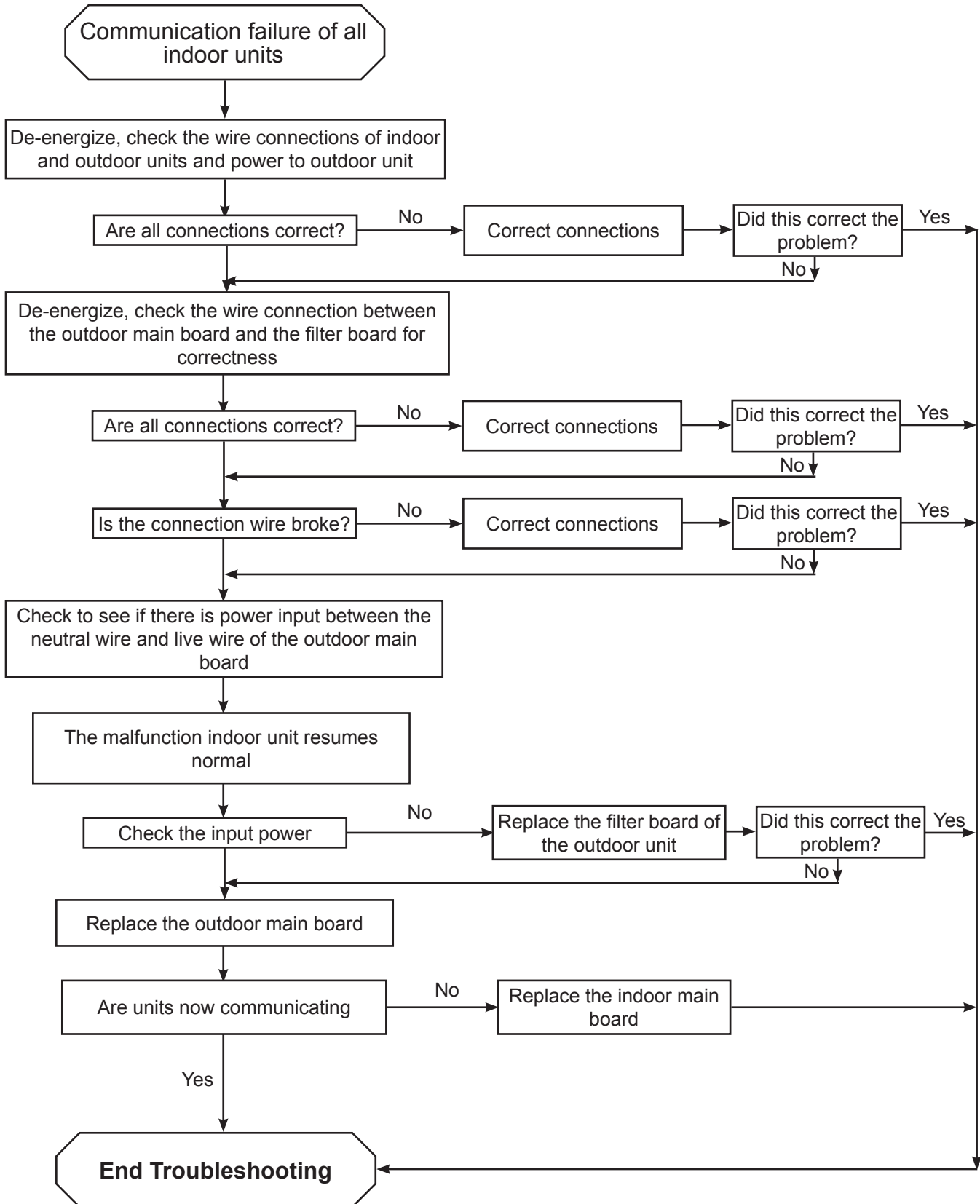

Error Code Diagnostics

E8 Error Code

Overload System Protection Problem

E8



Overload System Protection Problem

Status:

Cooling operation, compressor stops while indoor fans runs. Heating operation, complete unit stops

1. Incorrect refrigerant charge
2. Metering device problem
3. Compressor failure

Start Troubleshooting after unit is powered off for 20 minutes

Is the overload protector positioned and wired correctly?

No



Compressor Overload

Under normal ambient conditions, is the resistance of the overload less than 1000 ohms?

No

Replace Overload

Are the wires to the expansion valve connected per the wiring diagram?

No

Correct wiring problem



Metering Device

Resistance between the first 4 pins and the 5th pin should be less than 100 ohms

Replace coil of electronic expansion valve

Is system operating normal?

Yes

No

Check Refrigerant for leakage and proper charge

Replace outdoor AP1 control board

Is system working properly?

Yes

End Troubleshooting

Error Code Diagnostics

F1 - F5 Temperature Sensor Codes

See troubleshooting chart next page

Fault & Status

Possible Causes

F1



Indoor ambient temperature sensor is open or short circuited.

Status:

During cooling & dehumidifying, indoor unit operates while other functions stop; During heating operation, complete unit stops

1. Loose or bad contact of indoor temperature sensor
2. Sensor wire leads not properly connected
3. Faulty sensor, check readings with charts
4. Main circuit board defective

F2



Indoor evaporator temperature sensor is open or short circuited.

Status:

After reaching set-point, all components stop operation, cooling and heating modes

1. Loose or bad contact of indoor temperature sensor
2. Sensor wire leads not properly connected
3. Faulty sensor, check readings with charts
4. Main circuit board defective

F3



Outdoor ambient temperature sensor is open or short circuited.

Status:

Cooling operation, compressor stops while indoor fans runs. Heating operation, complete unit stops

1. Loose or bad contact of outdoor temperature sensor
2. Sensor wire leads not properly connected
3. Faulty sensor, check readings with charts
4. Main circuit board defective

F4



Outdoor Mid-Coil condenser temperature sensor is open or short circuited.

Status:

Cooling operation, compressor stops while indoor fans runs. Heating operation, complete unit stops

1. Loose or bad contact of outdoor temperature sensor
2. Sensor wire leads not properly connected
3. Faulty sensor, check readings with charts
4. Main circuit board defective

F5



Outdoor discharge temperature sensor is open or short circuited.

Status:

Cooling operation, compressor stops after 3 minutes while indoor fans runs. Heating operation, complete unit stops after operating for 3 minutes

1. Loose or bad contact of outdoor temperature sensor, head of sensor should be inserted into the copper tubing
2. Sensor wire leads not properly connected
3. Faulty sensor, check readings with charts
4. Main circuit board defective

Temperature Sensor Troubleshooting

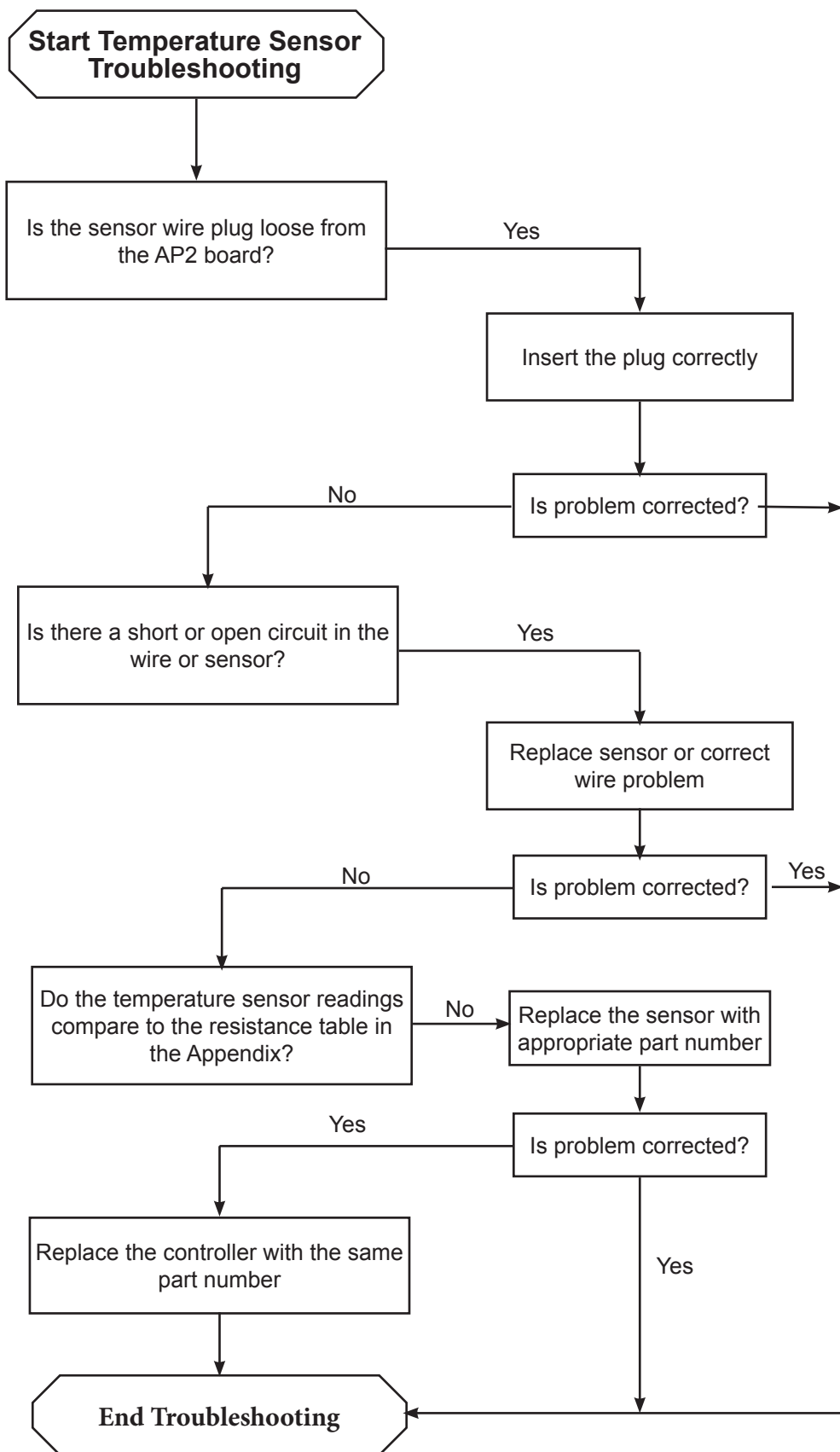

Error Code Diagnostics

F6, F8, F9 Temperature Sensor Codes

See troubleshooting chart preceding page

Fault & Status

Possible Causes

F6



Decrease frequency due to overload.

Status:

All systems operate normal with decrease in capacity

1. Refer to "E8" troubleshooting procedures

F8



Decrease frequency due to overcurrent.

Status:

All systems operate normal with decrease in capacity

1. Input voltage too low.
2. System pressure is too high

F9



Decrease frequency due to high discharge air.

Status:

All systems operate normal with decrease in capacity

1. Cooling load is too great
2. Outdoor ambient too high
3. Refrigerant undercharge
4. Electronic expansion valve fault

Start-up Failure Troubleshooting

Lc - Start-up Failure



Compressor Wires

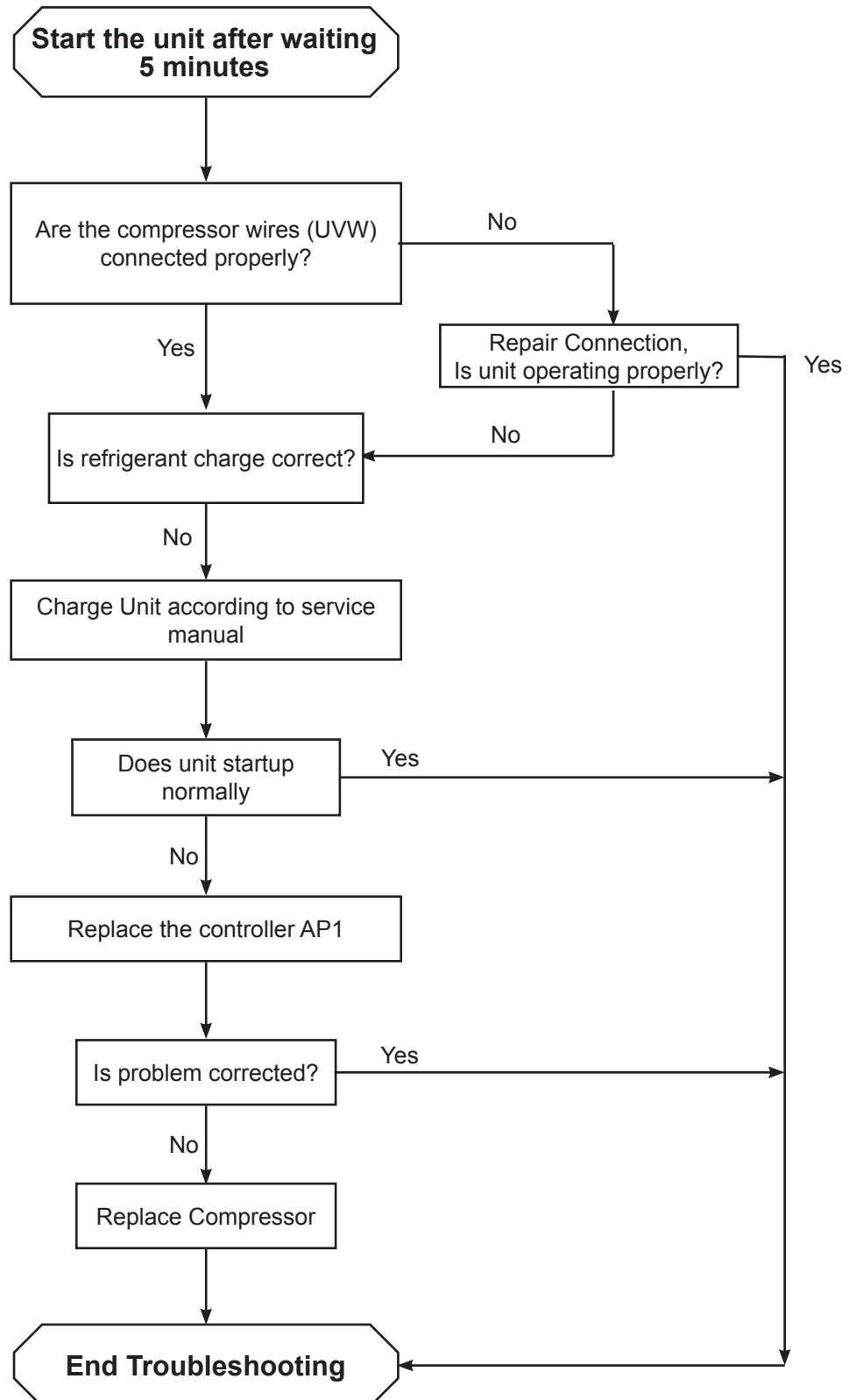

Error Code Diagnostics

HC

PFC (Power Factor Correction) Protection



HC

PFC (Power Factor Correction) Protection

Status:

During cooling & dehumidifying, indoor unit operates while other functions stop; During heating operation, complete unit stops

1. Check for damage to the reactor and PFC capacitor of the outdoor unit
2. Refer to troubleshooting procedure below

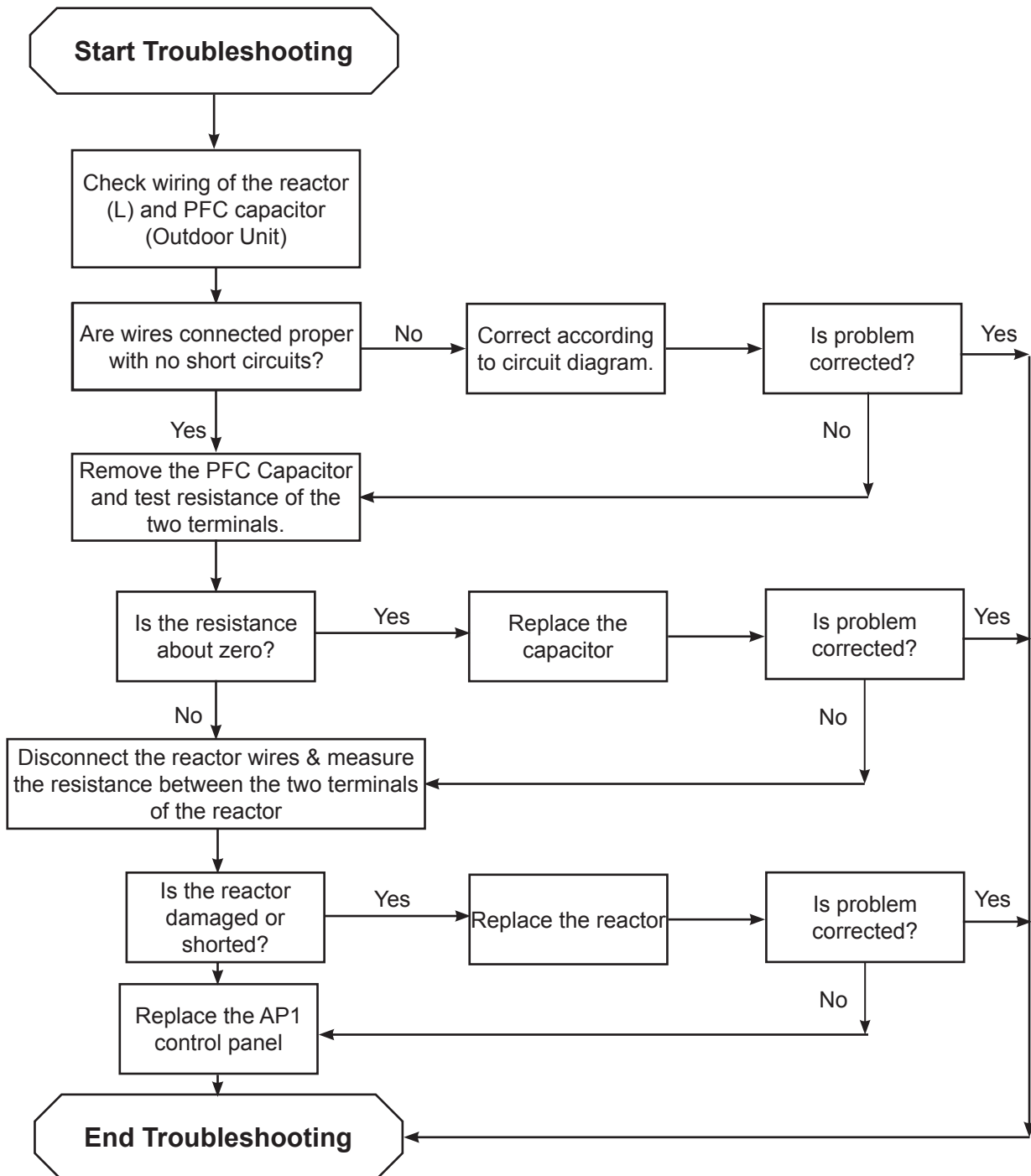

Error Code Diagnostics

H0 - H3 Error Codes

Fault & Status

Possible Causes

H0



Decrease frequency due to overload.

Status:

All systems operate normal with decrease in capacity

1. Refer to "E8" troubleshooting procedures

H1



Defrosting

Status:

Defrosting will occur in heating mode. Compressor will operate while indoor fan stops.

Normal function

H3



Overload Protection for Compressor

Status:

During cooling mode, compressor will stop, indoor fan will run. Heating mode all units stop.

1. Wiring terminal OVC-COMP is loose. In normal state the resistance should be less than 1 ohm,
2. Refer to "E4" troubleshooting procedures.

Error Code Diagnostics

H5 Error Code IPM Protection



Fault & Status

IPM Protection

Status:

During cooling mode, compressor will stop, indoor fan will run. Heating mode all units stop.

Possible Causes

1. Dirty indoor and outdoor coils
2. Faulty indoor or outdoor fans
3. High system pressure
4. Over charge of refrigerant

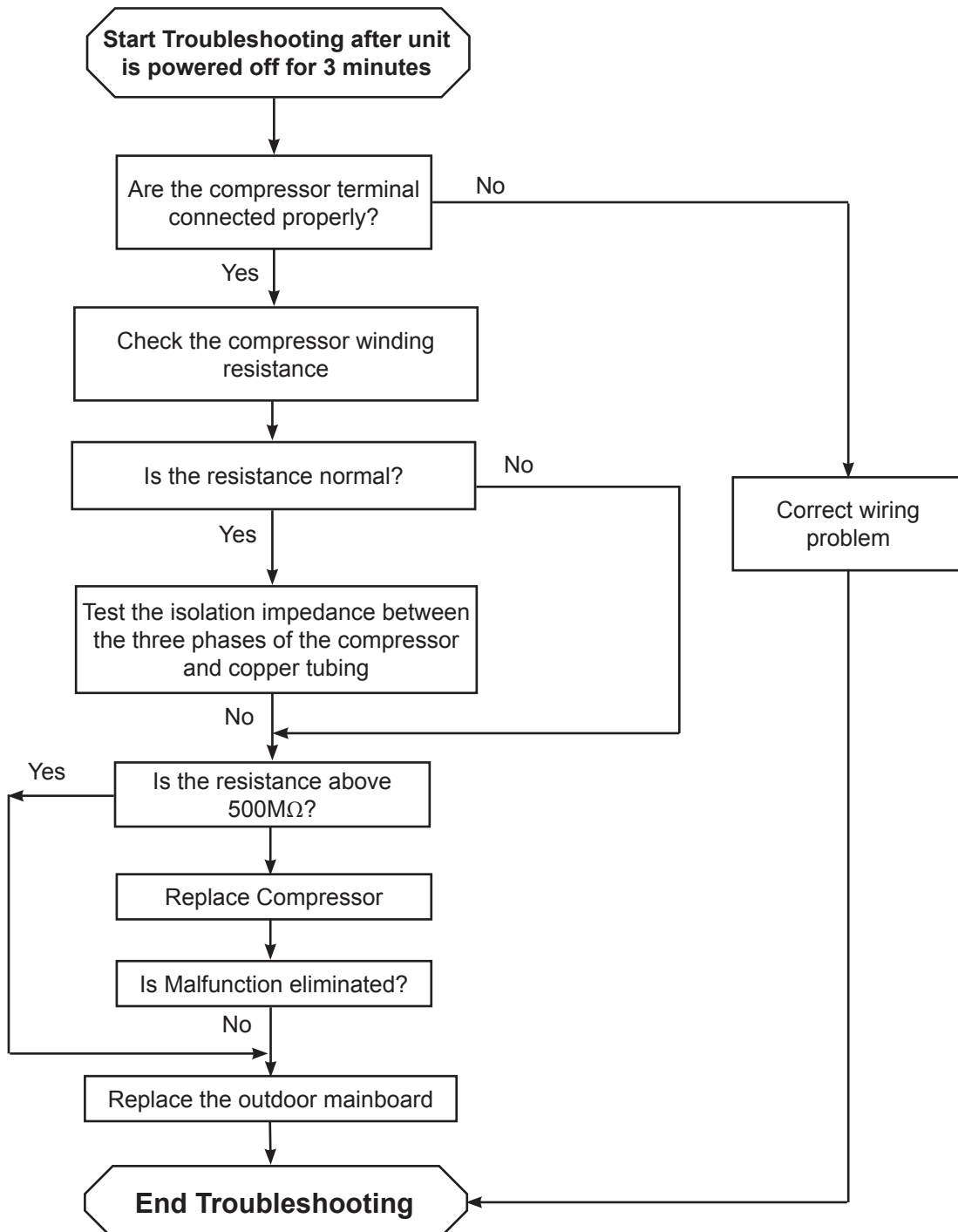

Error Code Diagnostics

H7 Error Code, continued on next page

De-synchronization of compressor

H7



Desynchronizing of compressor

Status:

During cooling mode, compressor will stop, indoor fan will run. Heating mode all units stop.

1. Check the resistance of the compressor terminals and connections to the compressor
2. Check for overcharge of refrigerant
3. Check for correct voltage
4. Check for dirty coils and filters

Troubleshooting Procedure for Synchronizing Fault after Unit is Started

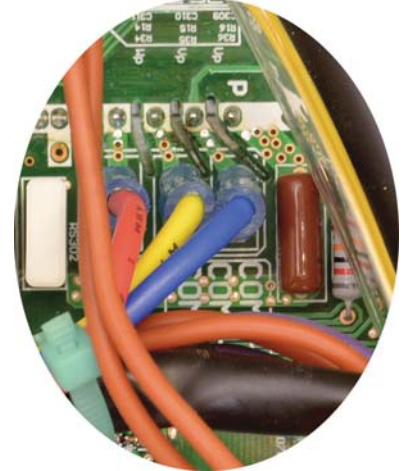
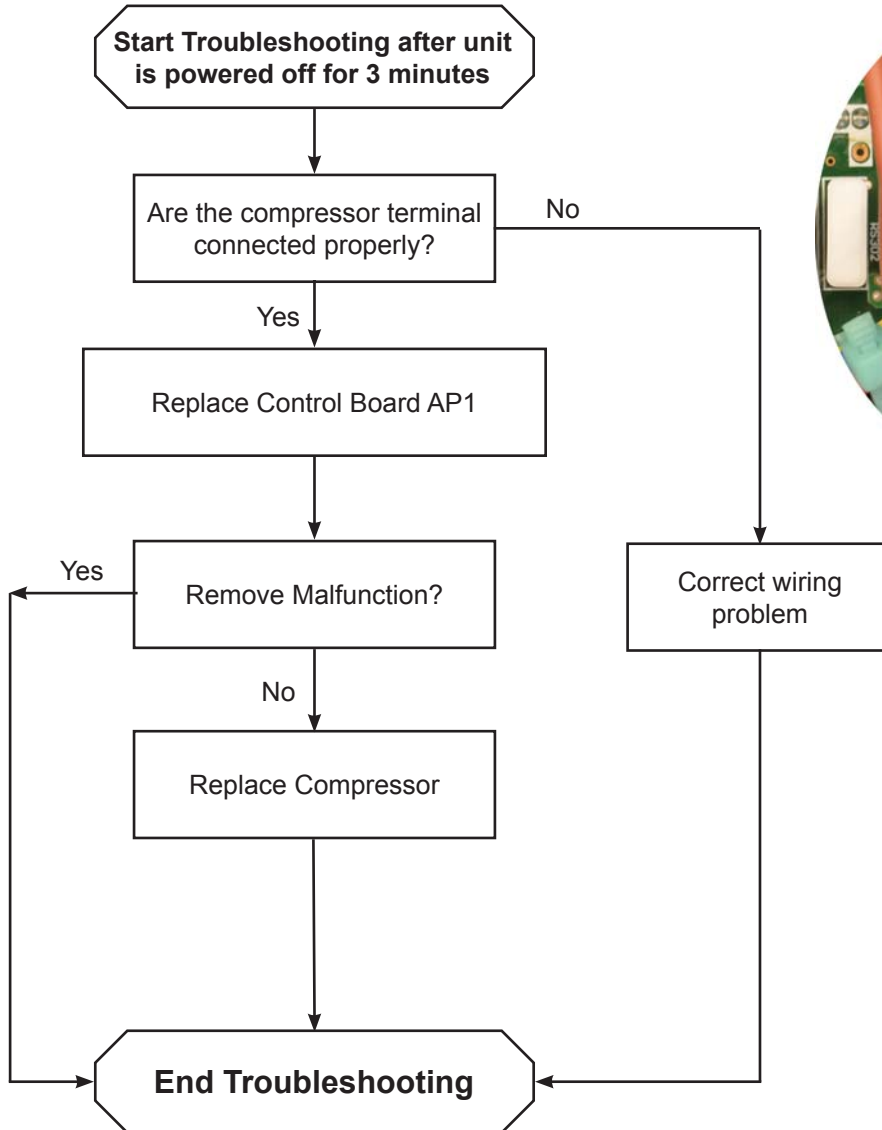

Compressor Wires

Error Code Diagnostics

H7 Error Code, continued

H7



Desynchronizing of compressor

Status:

During cooling mode, compressor will stop, indoor fan will run. Heating mode all units stop.

1. Check the resistance of the compressor terminals and connections to the compressor
2. Check for overcharge of refrigerant
3. Check for correct voltage

Troubleshooting Procedure for Synchronizing Fault During Operation

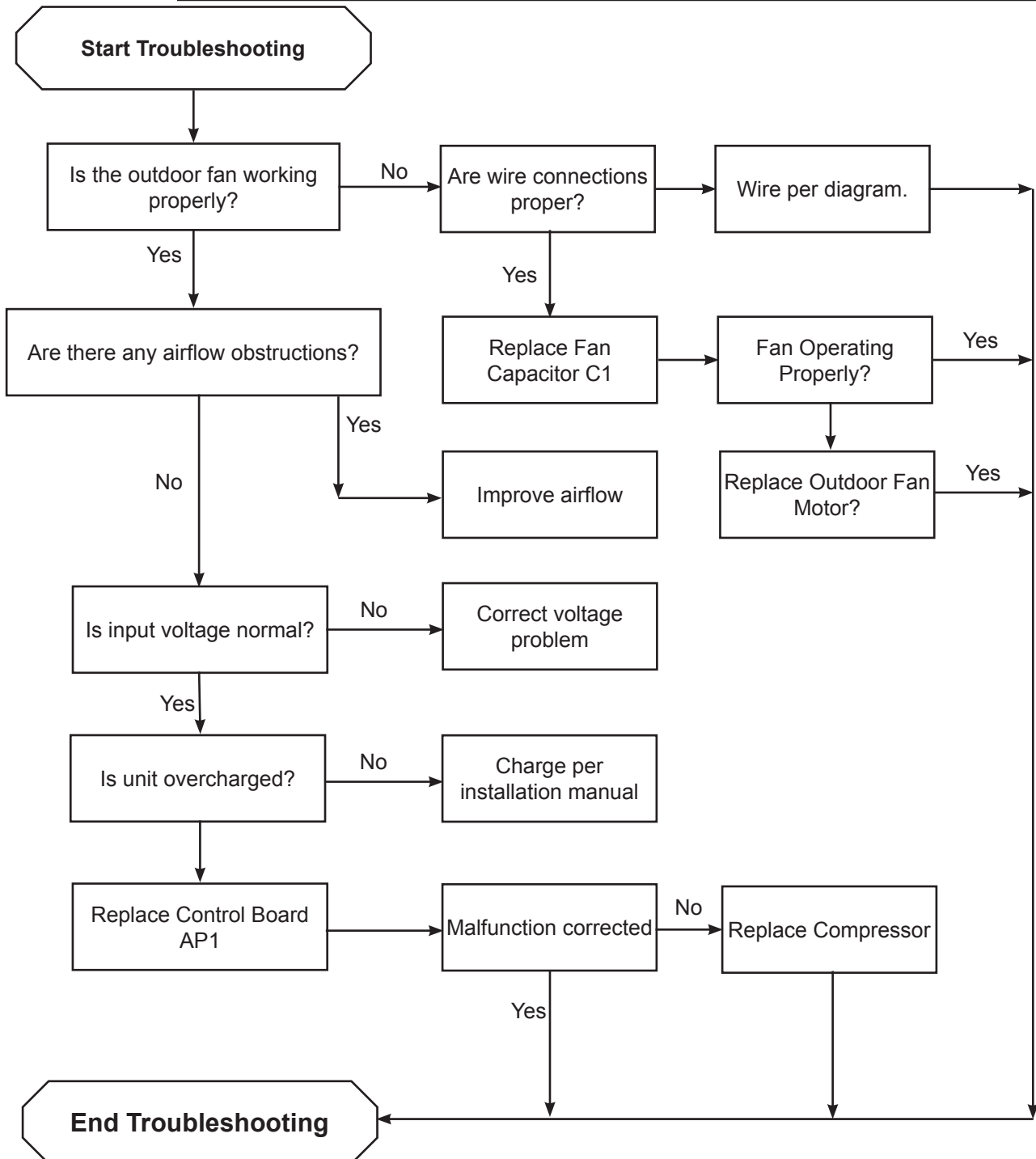

Error Code Diagnostics

U1, U3, U5, U7, U9 Error Codes

Fault & Status

Possible Causes

U1



Compressor Phase Detection Error

Status:

During cooling mode, compressor will stop, indoor fan will run. Heating mode all units stop.

1. Replace outdoor control panel AP1

U3



DC Bus-Bar Voltage Unstable

Status:

During cooling mode, compressor will stop, indoor fan will run. Heating mode all units stop.

1. Supply voltage is unstable

U5



Circuit Board Malfunction on Outdoor Unit

Status:

During cooling mode, compressor will stop, indoor fan will run. Heating mode all units stop.

1. Replace outdoor control panel AP1

U7



Reversing Valve Malfunction

Status:

During heating mode, complete unit will stop

1. Supply voltage is too low
2. Wiring terminal on reversing valve is loose or broken
3. Replace reversing valve

U9



Zero crossing, malfunction of Outdoor Unit

Status:

During cooling mode, compressor will stop, indoor fan will run. Heating mode all units stop.

1. Replace outdoor control panel AP1

Error Code Diagnostics

PH, PL, P5, P7, P8 Error Codes

Fault & Status

Possible Causes

PH



High DC Bus-Bar Voltage

Status:

During cooling mode, compressor will stop, indoor fan will run. Heating mode all units stop.

1. Measure the voltage on "L" & "N" on line voltage, if it is higher then 265vac, correct high voltage.
2. If AC voltage is normal, measure the voltage on the electrolytic capacitor on control panel AP1, if it is normal replace the AP1 board.

PL



Low DC Bus-Bar Voltage

Status:

During cooling mode, compressor will stop, indoor fan will run. Heating mode all units stop.

1. Measure the voltage on "L" & "N" on line voltage, if it is lower then 200vac, correct incoming voltage.
2. If AC voltage is normal, measure the voltage on the electrolytic capacitor on control panel AP1, if it is normal replace the AP1 board.

P5



Overcurrent Protection of Compressor Phase Current

Status:

During heating mode, complete unit will stop

1. Refer to "H7" troubleshooting

P7



Module Temperature Sensor Circuit Failure

Status:

During cooling mode, compressor will stop, indoor fan will run. Heating mode all units stop.

1. Replace outdoor control panel AP1

P8



Module High Temperature Protection

Status:

During cooling mode, compressor will stop, indoor fan will run. Heating mode all units stop.

1. After unit is de-energized for 20 minutes, check for proper thermal grease on IPM module of outdoor control panel AP1 and contact is good. If this is OK, replace AP1 control module of outdoor unit.

Error Code Diagnostics

PU Error Code Capacity Charging Malfunction

PU



Charging Malfunction of Capacitor

Status:

During cooling mode, compressor will stop, indoor fan will run. Heating mode all units stop.

1. Improper input voltage
2. Poor connection on reactor
3. Reactor damaged
4. Bad AP1 control board

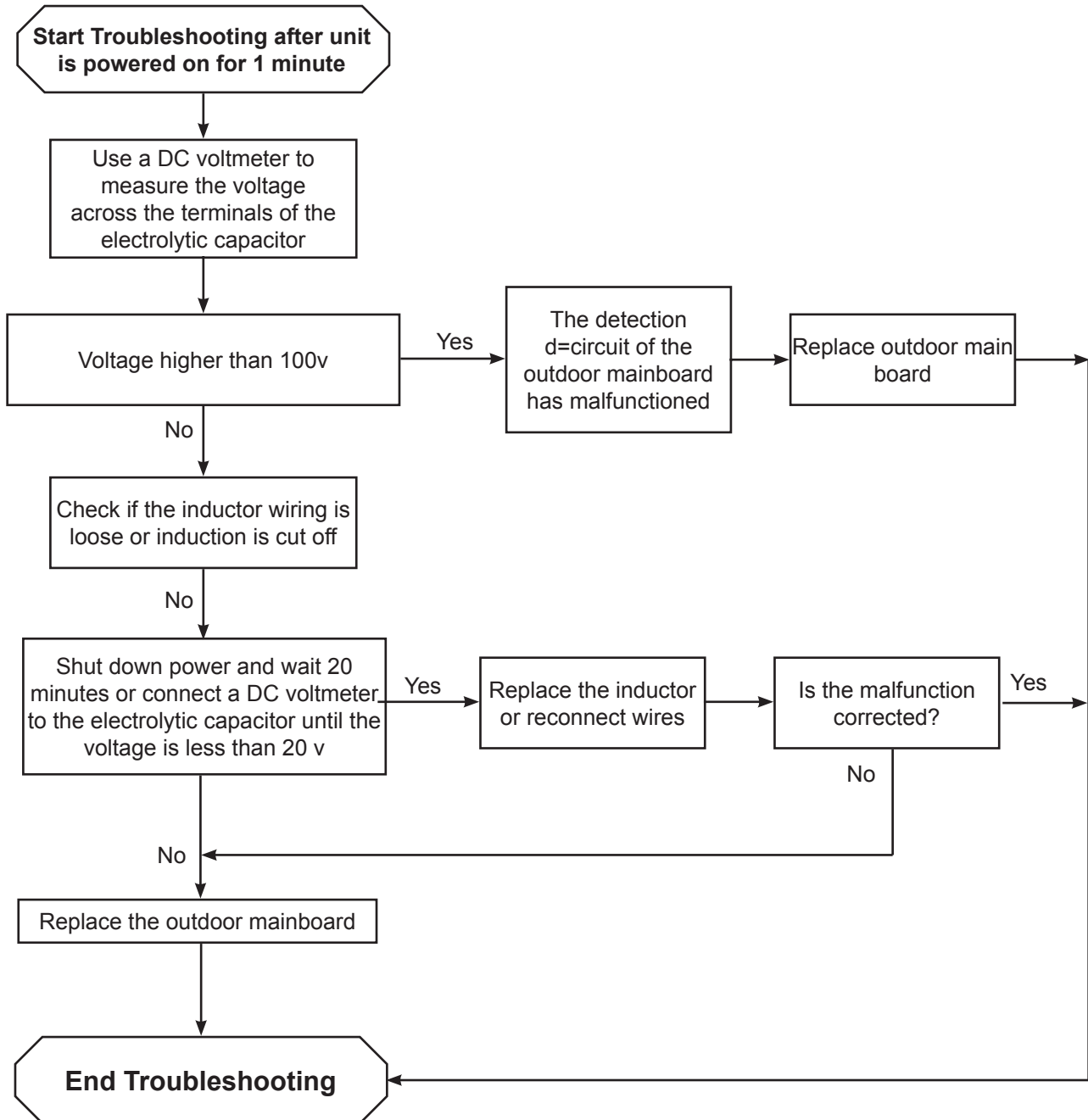

Disassembly of Neo Indoor Unit

115v model, Other models may vary slightly

Warning - Wait 10 minutes after power is disconnected before starting disassembly.

1. Remove Panel

Open the front panel, push the rotor shaft on both sides of the panel to make it separate from the groove. Remove the panel.

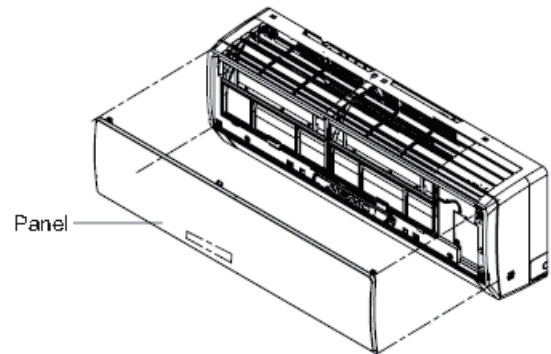

2. Remove filter

Loosen the clasp of the filter, pushing the filter inward and then lift it upward to remove.

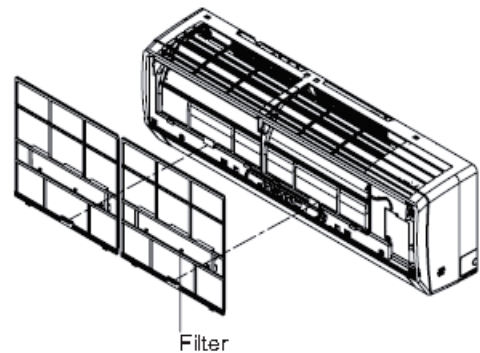

3. Remove horizontal louver and front case.

Remove axial sleeve of horizontal louver. Bend the louver outwards and then remove the louver.

Loosen the screws of the electric box cover 2, then remove cover 2.

Open the screw cap on the front of the case, then remove the screws holding the front case. Remove the six clasps of the front case, then remove.

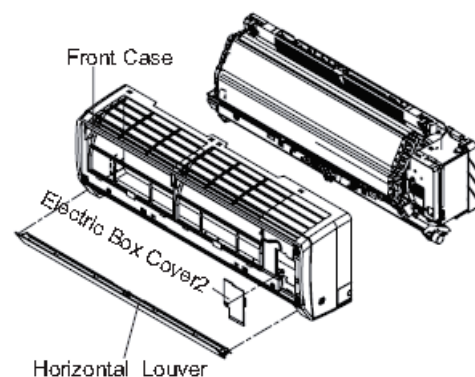

Disassembly of Neo Indoor Unit

115v model, Other models may vary slightly

Warning - Wait 10 minutes after power is disconnected before starting disassembly.

4. Remove electric box assembly

Remove the screws of the electric box assembly. Remove the screws at the joint of the earthing wire and evaporator. Loosen the clasp at the joint of the electric box cover and electric box. Remove the two screws on the display. Remove the electric box assembly.

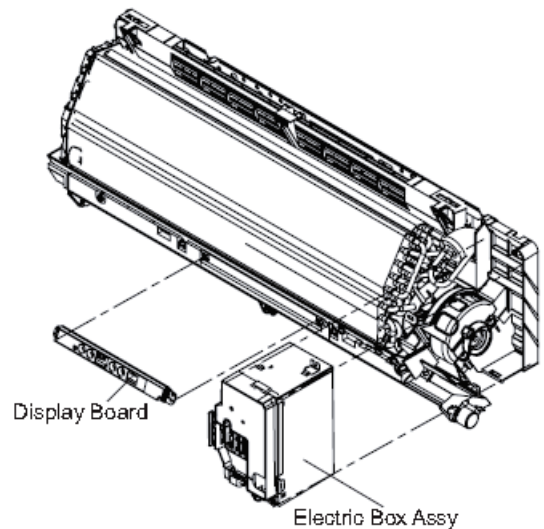

5. Remove evaporator

Remove the screws of the press plate of the connecting pipe. Remove press plate of the connecting pipe.

Remove the three screws at the joint of the evaporator and rear case. Adjust slightly the pipe on the evaporator. Remove the evaporator.

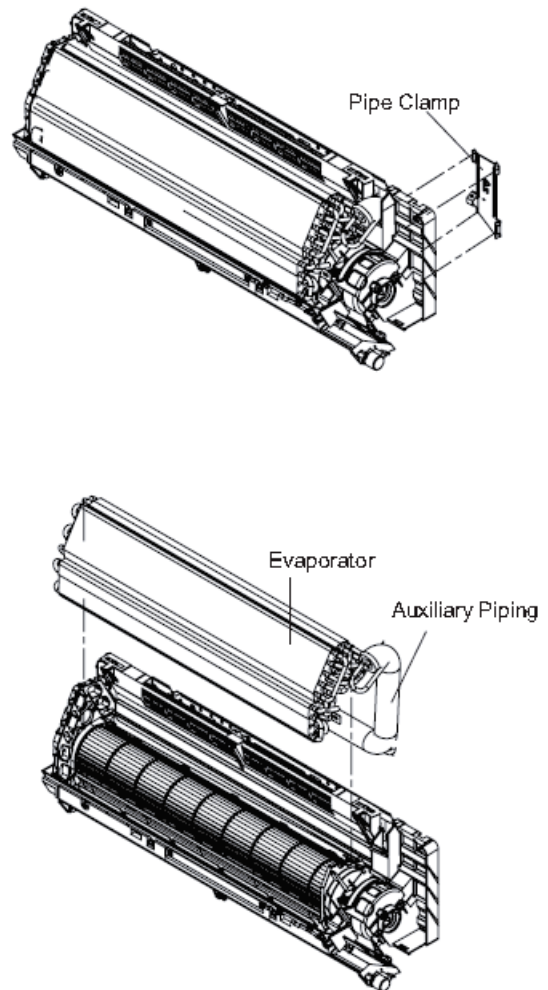

Disassembly of Neo Indoor Unit

115v model, Other models may vary slightly

Warning - Wait 10 minutes after power is disconnected before starting disassembly.

6. Remove motor and axial flow blade

Step 1.

Remove the screws of step motor and then remove the motor.

Remove the screw of the motor press plate and then remove the press plate.

Remove the screws at the joint of the cross flow blade and the motor. Take down the motor.

Step 2.

Remove the cross flow blade.

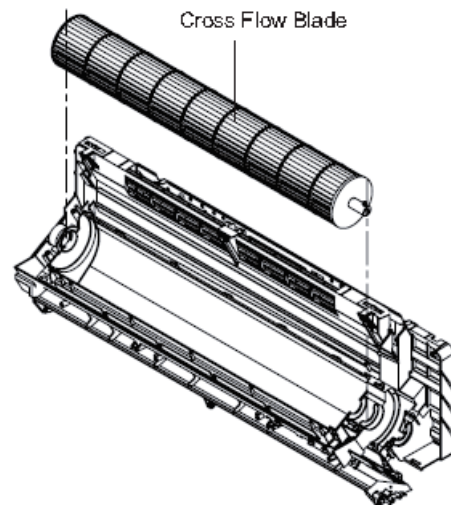
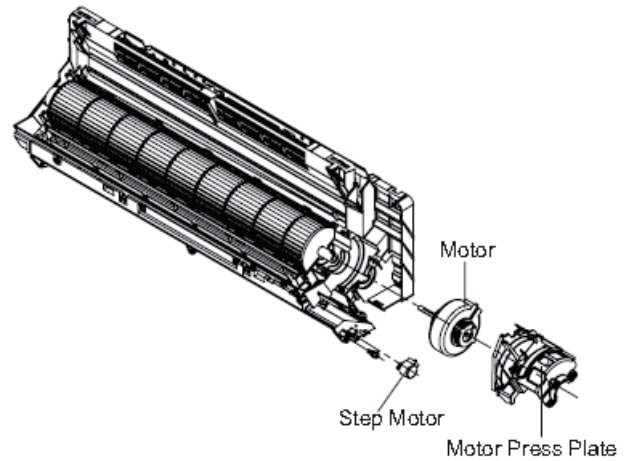

Disassembly of Neo Outdoor Unit

115v model, Other models may vary slightly

Warning - Wait 10 minutes after power is disconnected before starting disassembly.

1. Remove panel

Open the front panel. Push the rotor shaft on both sides of the panel to make it separate from the groove. Remove the panel.

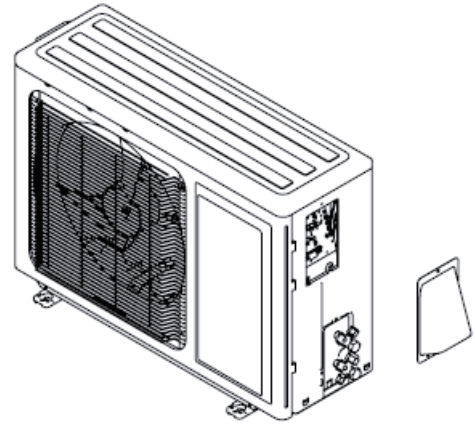

2. Remove top cover

Remove connecting screws connecting the top cover plate with the front panel and the right side plate, and then remove the top cover.

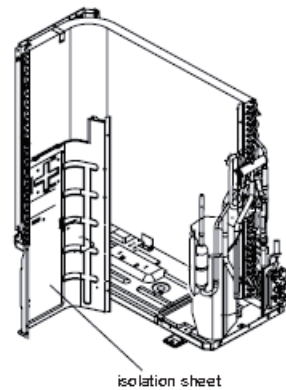

3. Remove front grille

Remove connection screws between the front grille and the front panel. Then remove the front grille.

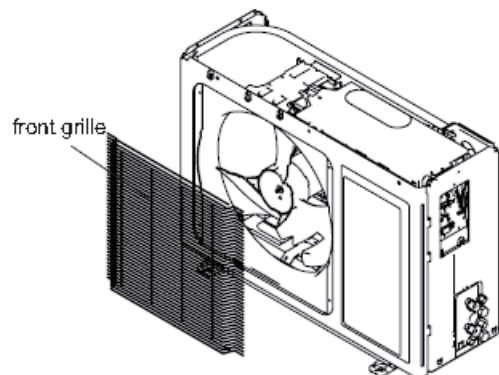

Disassembly of Neo Outdoor Unit

115v model, Other models may vary slightly

Warning - Wait 10 minutes after power is disconnected before starting disassembly.

4. Remove front panel

Remove connecting screws connecting the front panel with the chassis and the motor support, and then remove the front panel.

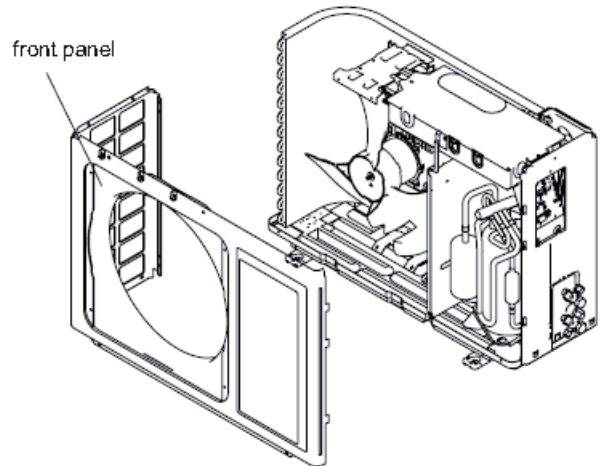

5. Remove right side plate

Remove connection screws connecting the right side plate with the valve support and the electric box. Then remove the right side plate.

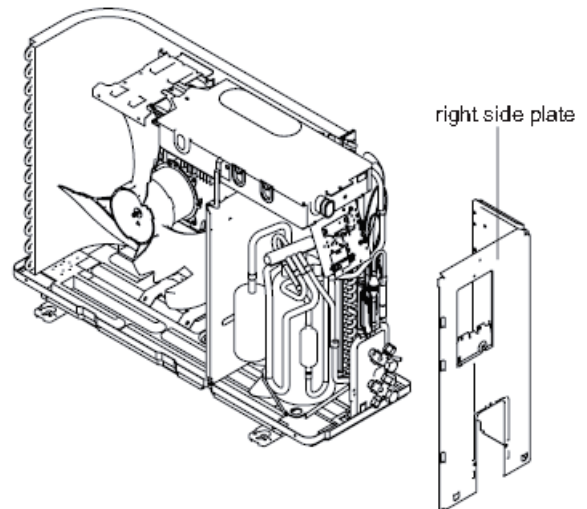

6. Remove axial flow blade

Remove the nut attached to the blade and then remove the axial flow blade.

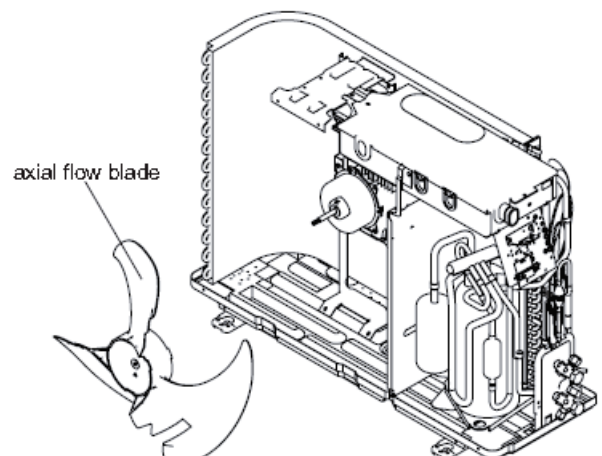

Disassembly of Neo Outdoor Unit

115v model, Other models may vary slightly

Warning - Wait 10 minutes after power is disconnected before starting disassembly.

7. Remove motor and motor support

Remove the four tapping screws attached to the motor. Pull out the lead-out wire and remove the motor. Remove the two tapping screws fixing the motor support. Lift motor support to remove it.

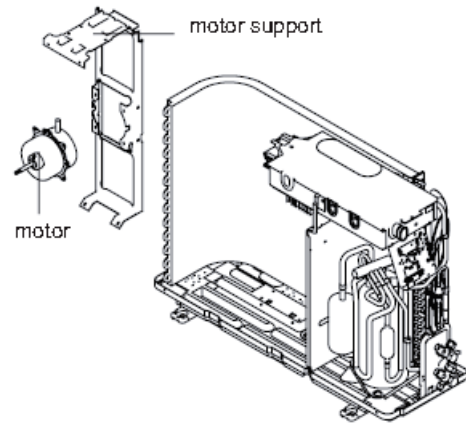

8. Remove electric box assembly

Remove the two screws attached to the cover of the electric box. Lift to remove the cover. Loosen the wire and disconnect the terminal. Lift to remove the electric box assembly

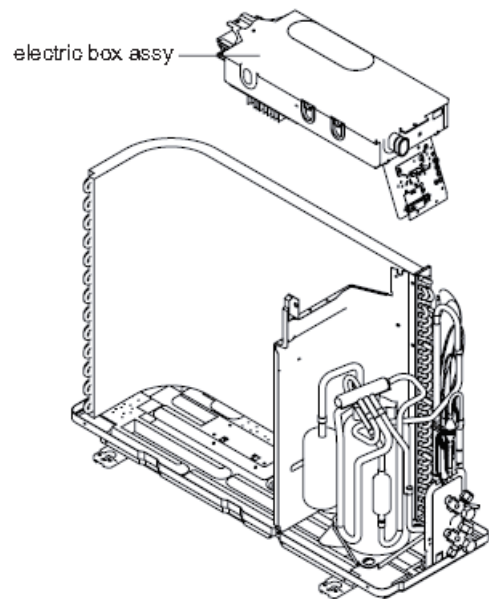

9. Remove clapboard sub-assembly

Loosen the screws of the clapboard sub assembly. The clapboard sub-assembly has a hook on the lower side. Lift and pull the clapboard sub-assembly to remove.

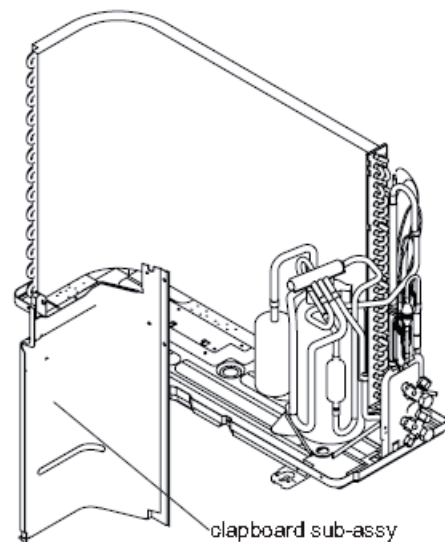

Disassembly of Neo Outdoor Unit

115v model, Other models may vary slightly

Warning - Wait 10 minutes after power is disconnected before starting disassembly.

10. Remove 4-way valve assembly

Unscrew the fastening nut of the 4-way valve assembly coil and remove the coil. Wrap the 4-way valve assembly with wet cotton and unsolder the four weld spots connecting the 4-way valve assembly to take it out (Note: Refrigerant should be discharged first). Welding process should be as quickly as possible and keep wrapping wet cotton all the time. Be sure not to burn out the lead-out wire of compressor.

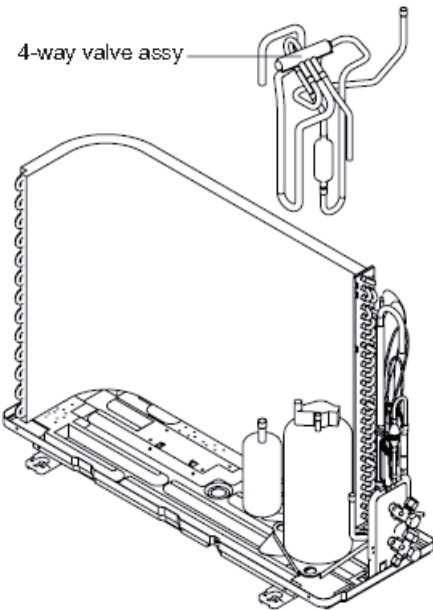

11 Remove compressor

Remove the three footing screws of the compressor and remove the compressor

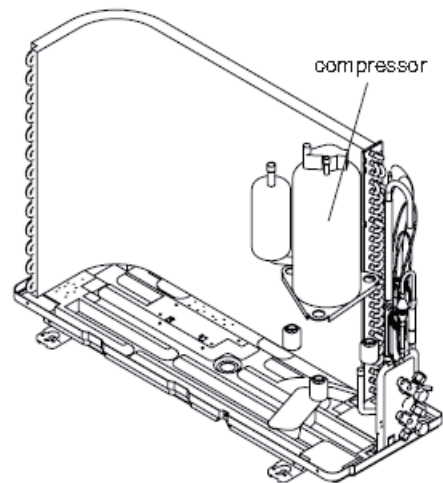

Disassembly of Indoor Unit

9K 240 volt unit, models may vary slightly

Warning - Wait 10 minutes after power is disconnected before starting disassembly.

1. Remove Panel

Open the front panel. Push the rotor shaft on both sides of the panel to make it separate from the groove. Remove the panel.

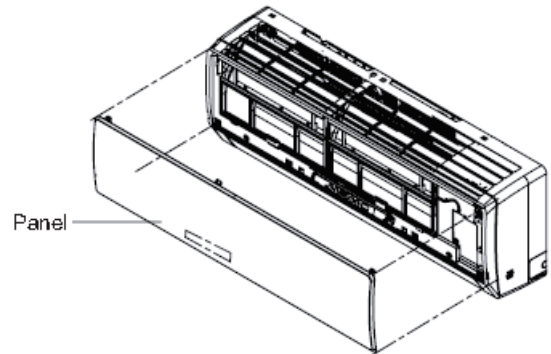

2. Remove filter

Loosen the clasp of the filter. Push the filter inward and then draw it upward to remove it.

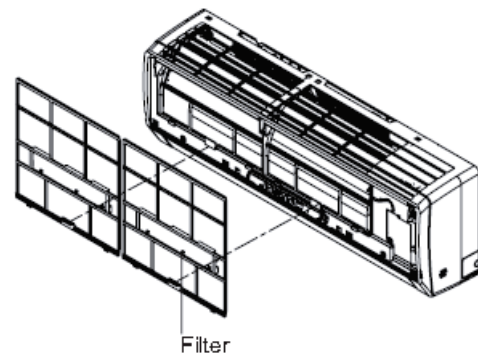

3. Remove horizontal louver and front case

Remove axial sleeve of horizontal louver. Bend the louver outwards and then remove the louver.

Loosen the screws of the electric box cover "2" with screwdriver. Remove the electric box cover "2."

Open the screw cap on the front case. Remove the screws fixing the front case. Loosen the six clasps of the front case. Remove the front case.

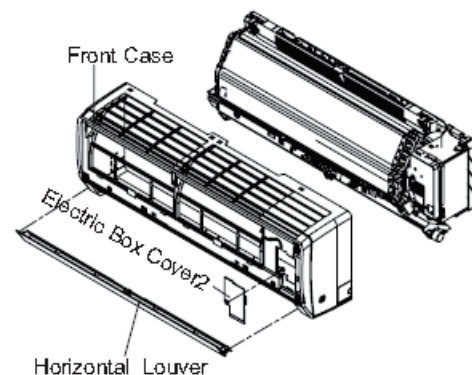

Disassembly of Indoor Unit

9K 240 volt unit, models may vary slightly

Warning - Wait 10 minutes after power is disconnected before starting disassembly.

4. Remove electric box assembly

Remove the screws of the electric box assembly. Remove the screws at the joint of the earthing wire and evaporator. Loosen the clasp at the joint of the electric box cover and electric box. Remove the two screws on the display. Remove the electric box assembly

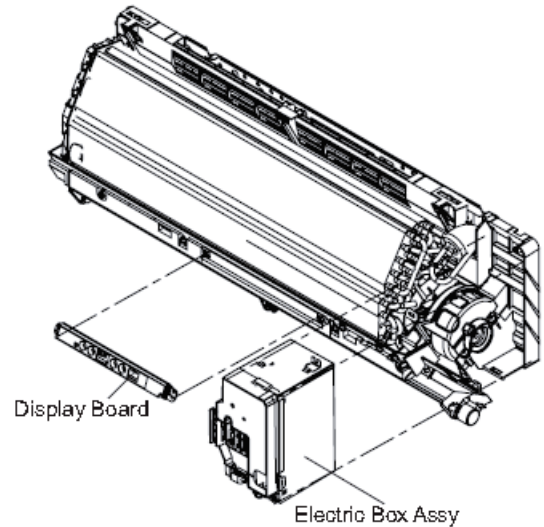

5. Remove evaporator

Remove the screws of the press plate of the connecting pipe. Remove press plate of the connecting pipe.

Remove the three screws at the joint of the evaporator and rear case. Adjust slightly the pipe on the evaporator. Remove the evaporator.

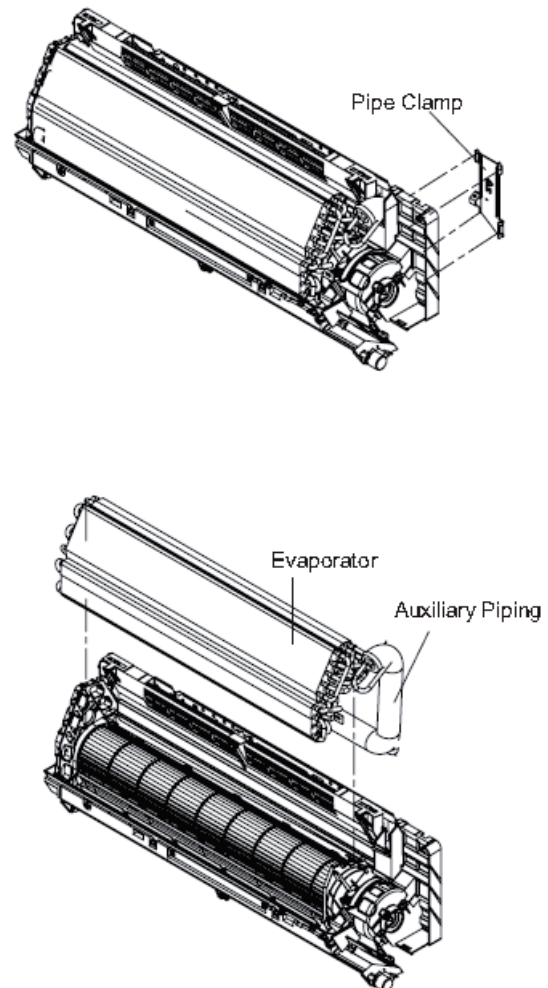

Disassembly of Indoor Unit

9K 240 volt unit, models may vary slightly

Warning - Wait 10 minutes after power is disconnected before starting disassembly.

6. Remove Panel

Remove the screws of step motor and then remove the motor.

Remove the screw of the motor press plate and then remove the press plate.

Remove the screws at the joint of the cross flow blade and the motor. Take down the motor.
Remove the cross flow blade.

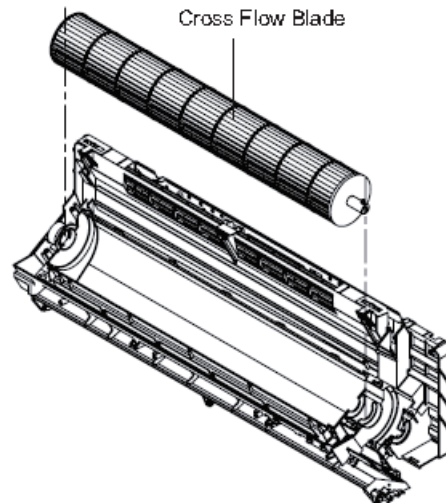
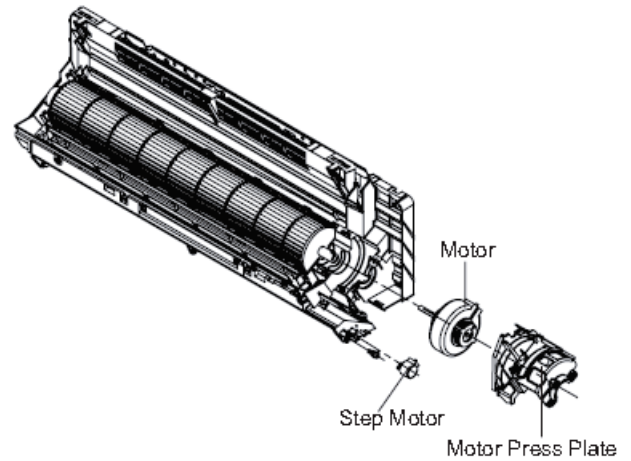

Disassembly of Outdoor Unit

9K 240 volt unit

Warning - Wait 10 minutes after power is disconnected before starting disassembly.

1. Remove cable plate and valve cover

Remove screws attached to cable cross plate and valve cover then remove them

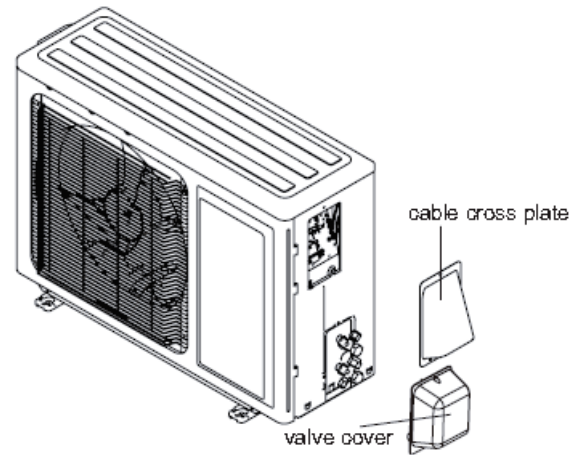

2. Remove top cover

Remove screws connecting the top cover plate with the front panel and the right side plate, and then remove the top cover

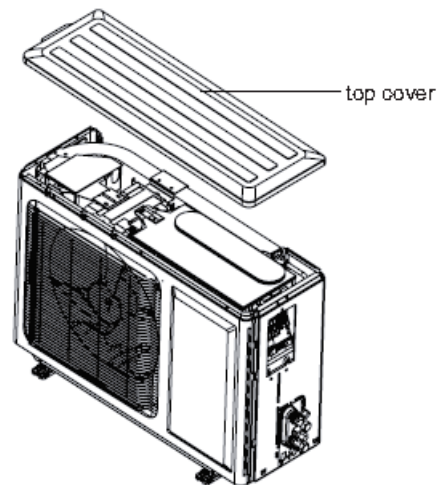

3. Remove reactor sub-assy

Remove screws holding reactor sub-assembly and then pull the reactor sub-assembly upwards to remove it. Remove screws on the reactor sub-assembly cover and then remove the reactor

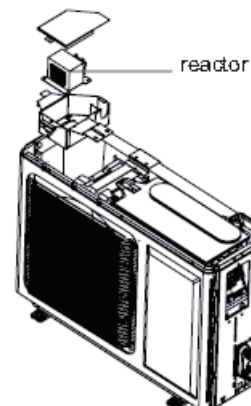

Disassembly of Outdoor Unit

9K 240 volt unit

Warning - Wait 10 minutes after power is disconnected before starting disassembly.

4. Remove front grille

Remove screws between the front grille and the front panel. Then remove the front grille

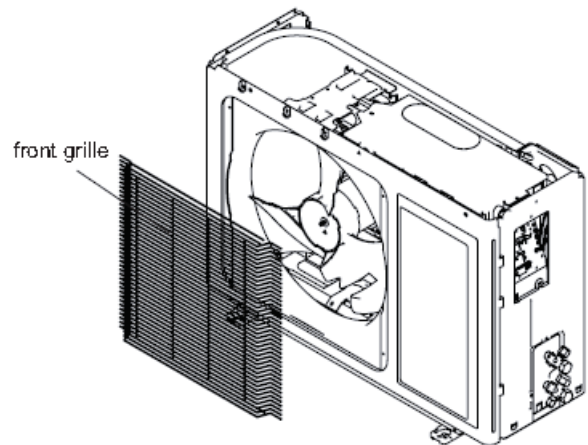

5. Remove front panel

Remove screws connecting the front panel with the chassis and the motor support, and then remove the front panel

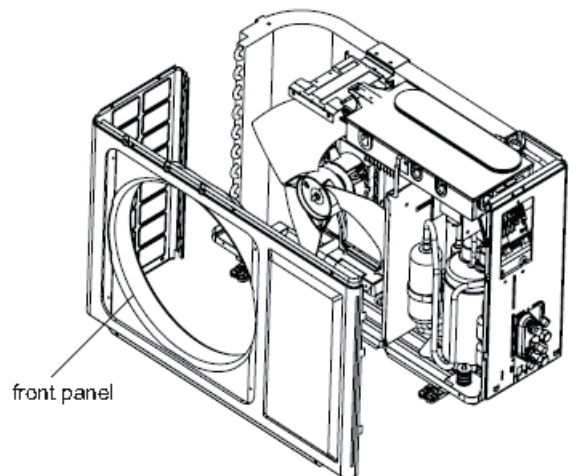

6. Remove right side plate

Remove screws connecting the right side plate with the valve support and the electric box. Then remove the right side plate

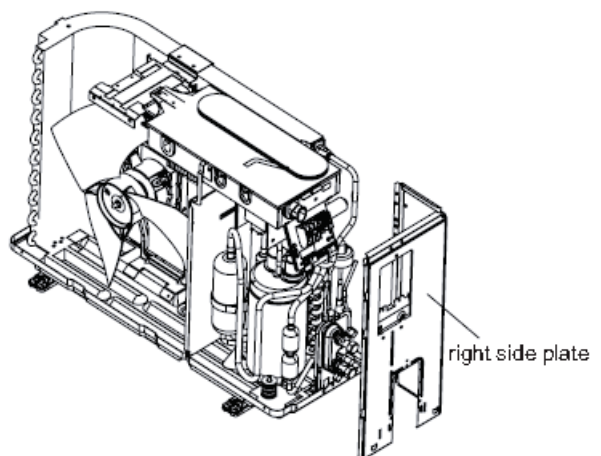

Disassembly of Outdoor Unit

9K 240 volt unit

Warning - Wait 10 minutes after power is disconnected before starting disassembly.

7. Remove axial flow blade

Remove the nut attached to the blade and then remove the axial flow blade

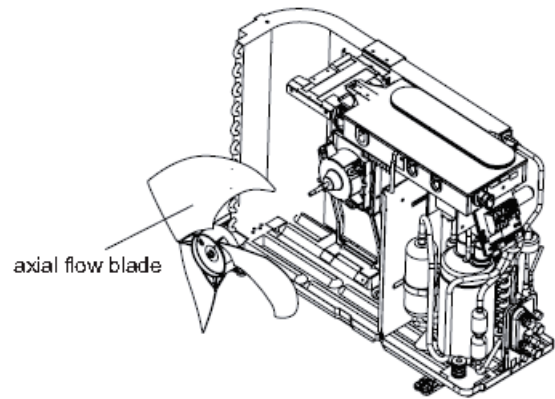

8. Remove motor and support assy

Remove the four tapping screws attached to the motor. Pull out the lead wire and remove the motor. Remove the two tapping screws attached to the motor support. Lift motor support to remove it.

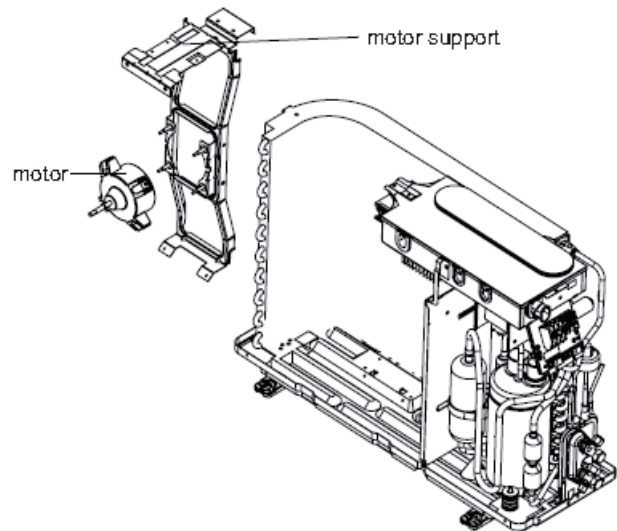

9. Remove electric box assy

Remove the two screws attached to the cover of the electric box. Lift to remove the cover. Loosen the wire and disconnect the terminal. Lift to remove the electric box assembly.

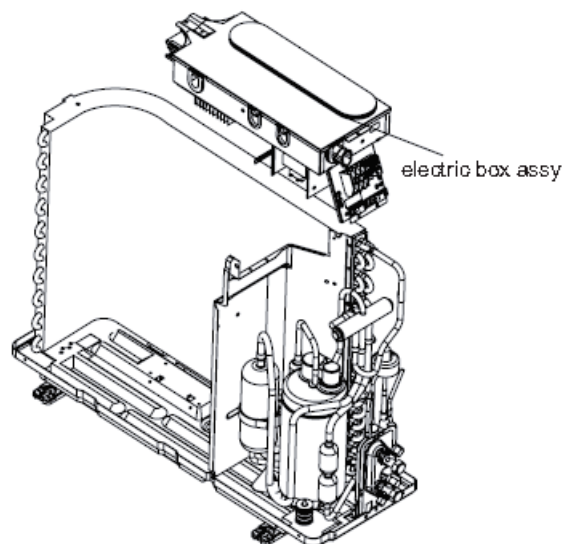

Disassembly of Outdoor Unit

9K 240 volt unit

Warning - Wait 10 minutes after power is disconnected before starting disassembly.

10. Remove clapboard sub-assy

Loosen the screws of the clapboard sub-assembly. The clapboard sub-assembly has a hook on the lower side. Lift and pull the clapboard sub-assembly to remove.

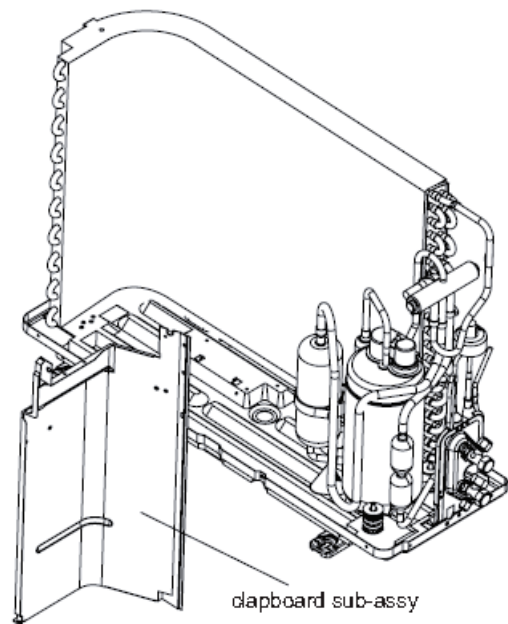

11. Remove 4-way valve

Unscrew the attached nut of the 4-way valve assembly coil and remove the coil. Wrap the 4-way valve assembly with wet cotton and unsolder the four weld spots connecting the 4-way valve assembly to take it out (Note: Refrigerant should be discharged first). Welding process should be as quick as possible and keep wrapping wet cotton all the time. Be sure not to burn out the lead wire of the compressor.

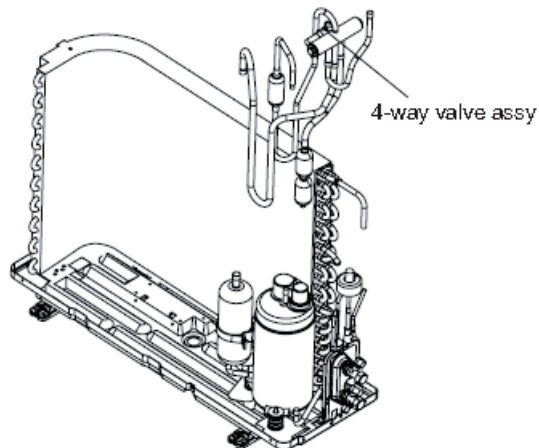

12. Remove compressor

Remove the three footing screws of the compressor and remove the compressor.

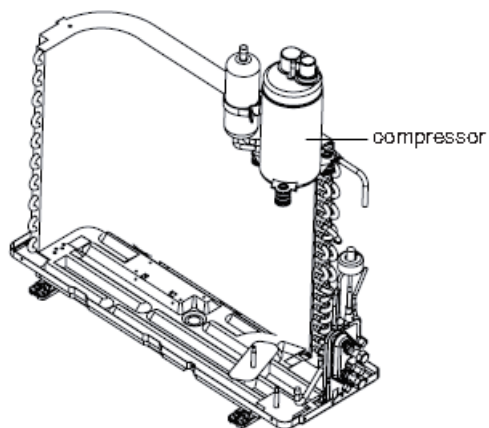

Disassembly of Outdoor Unit

12K 240 volt unit

Warning - Wait 10 minutes after power is disconnected before starting disassembly.

1. Remove top cover and rear grille

Remove screws used for attaching the top cover, pull the top cover upward to remove it. Twist off the screws used for fixing the rear grille, pull the rear grille upward to remove it

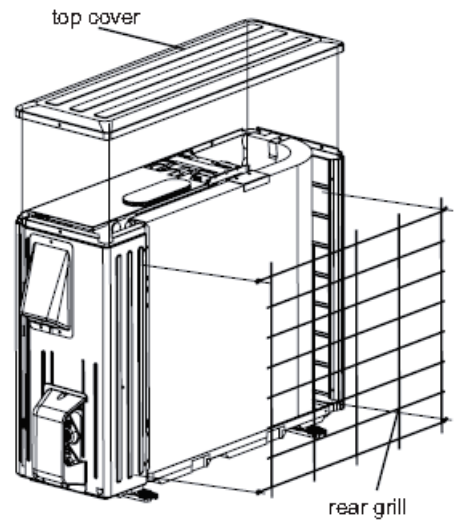

2. Remove front grille and front panel

Remove the screws connecting the front grille and the front panel. Remove the front grille. Remove the screws attaching the panel, pull it upward, loosen the clasp on the right side, rotate it to the left and then remove the front panel.

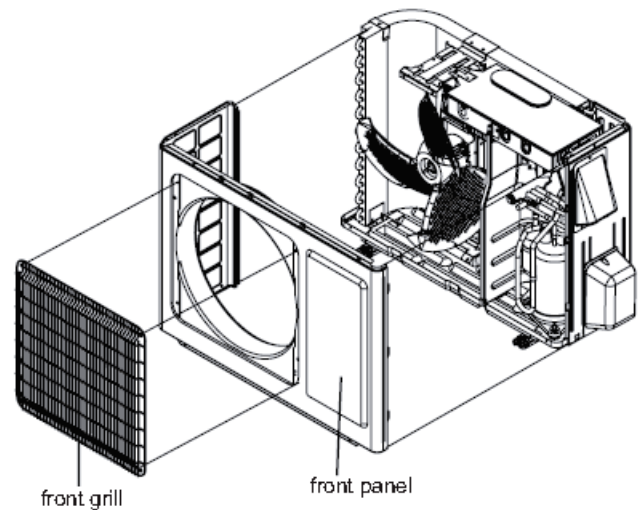

Disassembly of Outdoor Unit

12K 240 volt unit

Warning - Wait 10 minutes after power is disconnected before starting disassembly.

3. Remove electric box sub-assy

Remove the screw connecting the electric box cover with electric box, and then remove electric box cover. Remove the screws fixing the electric box sub-assembly; loosen the wire bundle; pull out the wiring terminals and then pull the electric box upwards to remove it.

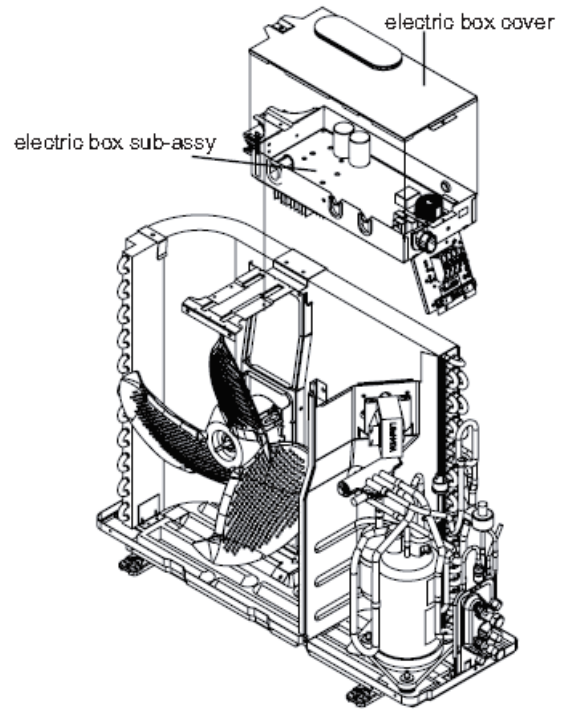

4. Remove axial flow fan and motor

Remove the nuts attaching the blade and then remove the axial flow fan.

Remove the four tapping screws fixing the motor; disconnect the leading wire insert of the motor and then remove the motor. Remove the two tapping screws fixing the motor support and then pull the motor support upwards to remove it.

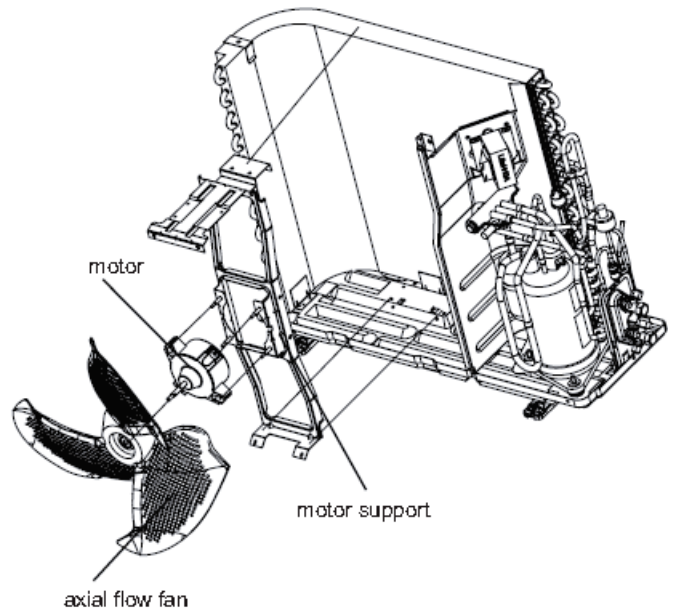

Disassembly of Outdoor Unit

12K 240 volt unit

Warning - Wait 10 minutes after power is disconnected before starting disassembly.

5. Remove the reactor and isolation sheet

Remove screws attached to reactor and then remove the reactor.

Remove screws attached to the isolation sheet and then remove the isolation sheet

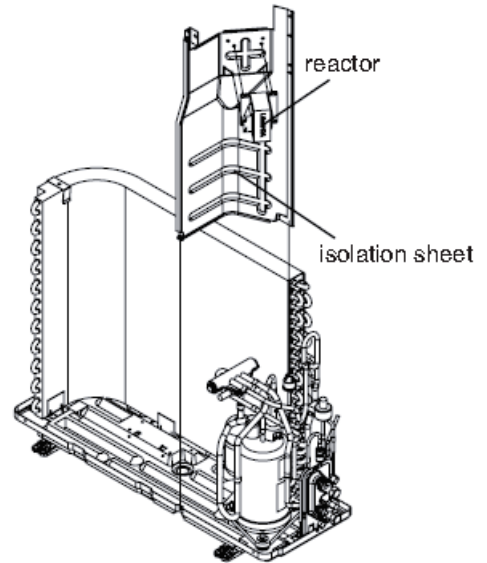

6. Remove f4-way valve assy and condenser

Discharge the refrigerant completely; unsolder the pipeline connecting the compressor and the condenser assembly, and then remove the 4-way valve assembly.

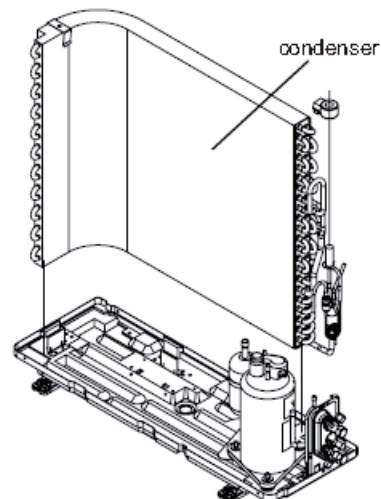
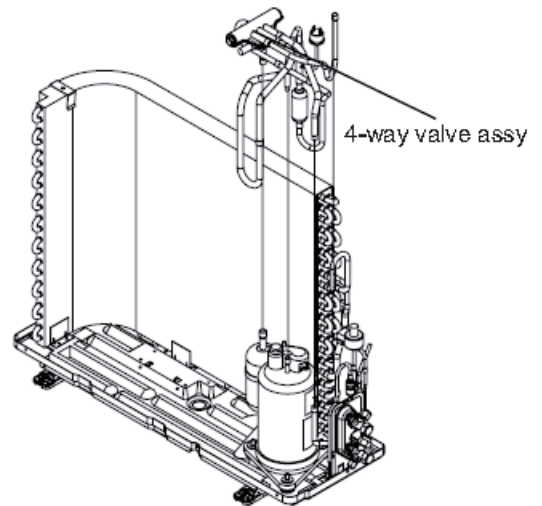

Disassembly of Outdoor Unit

12K 240 volt unit

Warning - Wait 10 minutes after power is disconnected before starting disassembly.

7. Remove the gas and liquid valves and valve support

Remove the screws attached to the gas valve and unsolder the welding joint between the gas valve and the air-return pipe to remove the gas valve (NOTE: Discharge the refrigerant completely before un-soldering; When un-soldering, wrap the gas valve with a wet cloth completely to avoid damage to the valve cause by high temperature). Remove the screws attached to the liquid valve and unsolder the welding joint connecting the liquid valve to the Y-type pipe to remove the liquid valve. Remove the screws attached to the valve support with the chassis sub-assembly, then remove the valve support.

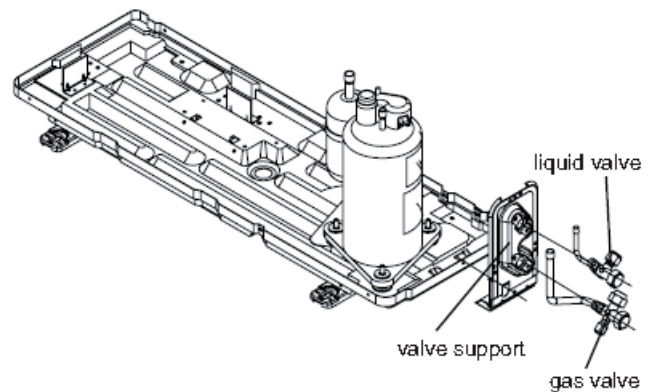

8. Remove compressor

Remove the three nuts on the compressor feet and then remove the compressor.

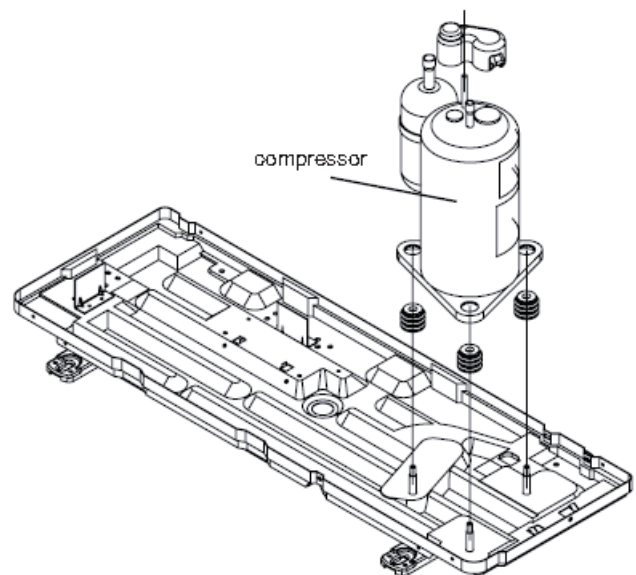

Disassembly of Outdoor Unit

18K 240 volt unit

Warning - Wait 10 minutes after power is disconnected before starting disassembly.

1. Remove top cover and handle

Remove the screws used for attaching the handle, pull the handle upward to remove it.

Loosen the screws holding the valve cover and then remove the valve cover.

Remove the screws used for attaching the top cover, pull the top cover upward to remove it.

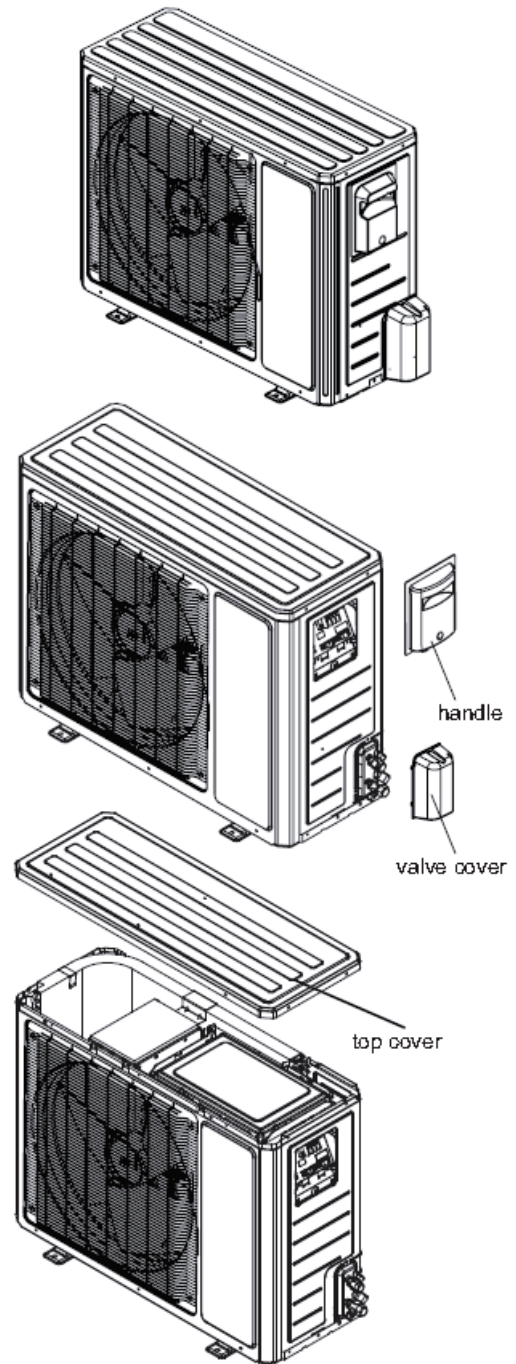

Disassembly of Outdoor Unit

18K 240 volt unit

Warning - Wait 10 minutes after power is disconnected before starting disassembly.

2. Remove front grille and front panel

Remove the screws connecting the front grille and the front panel.

Remove the front grille.

Remove the screws attached to the panel, pull it upward, loosen the clasp on the right side, and rotate it to the left and then remove the front panel

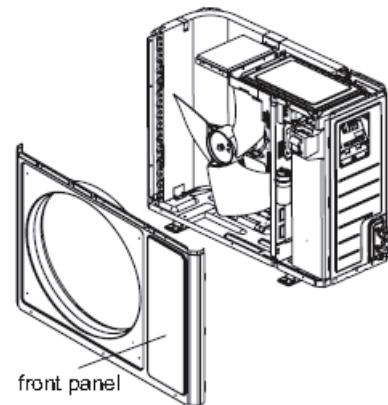
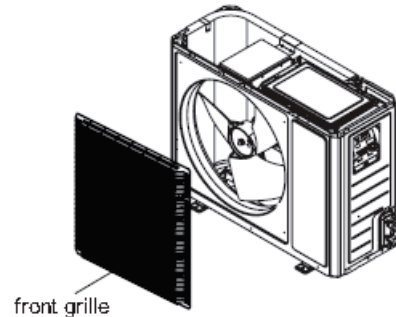

3. Remove right and left side plate

Remove the screws connecting the right side plate with the chassis, the valve support and the electric box, and then remove the right side plate assembly.

Remove the screws connecting the left side plate and the chassis, and then remove the left side plate assembly

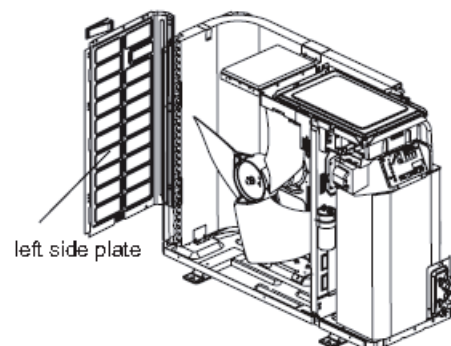
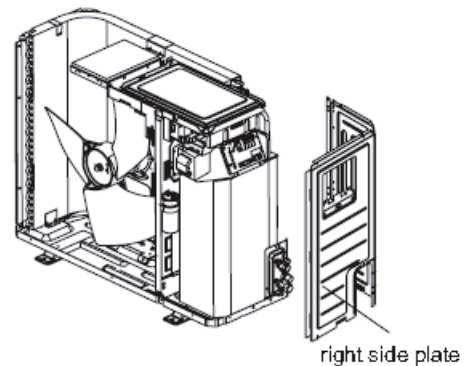

Disassembly of Outdoor Unit

18K 240 volt unit

Warning - Wait 10 minutes after power is disconnected before starting disassembly.

4. Remove axial flow fan

Remove the nuts attached to the blade and then remove the axial flow fan.

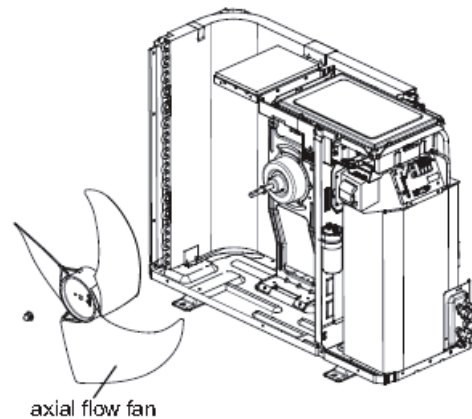

5. Remove electric box and electric shield

Remove the screws attached to the electric box sub-assembly; loosen the wire bundle; pull out the wiring terminals and then pull the electric box upwards to remove it.

Remove the screws on fireproof electric box and then remove the fireproof electric box.

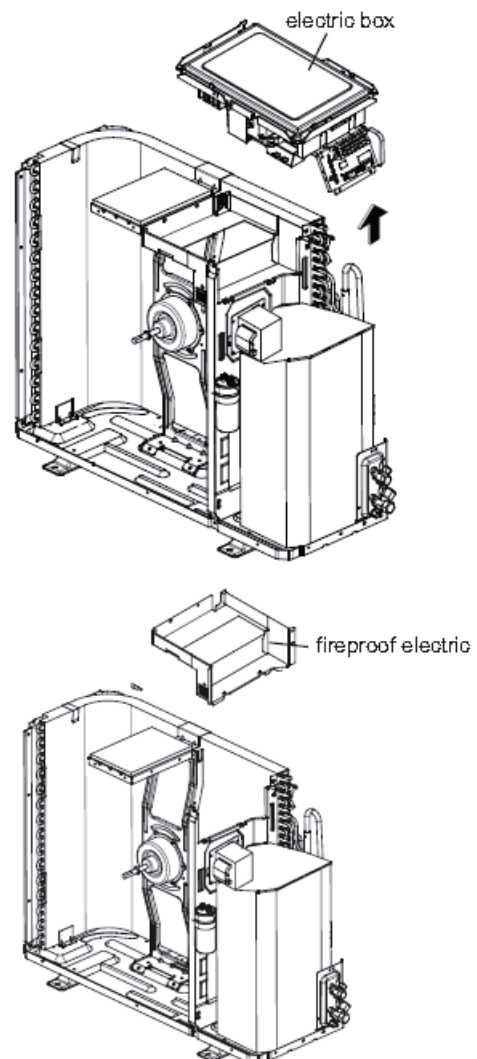

Disassembly of Outdoor Unit

18K 240 volt unit

Warning - Wait 10 minutes after power is disconnected before starting disassembly.

6. Remove sound proof sponge

Remove the soundproof sponge wrapping the compressor

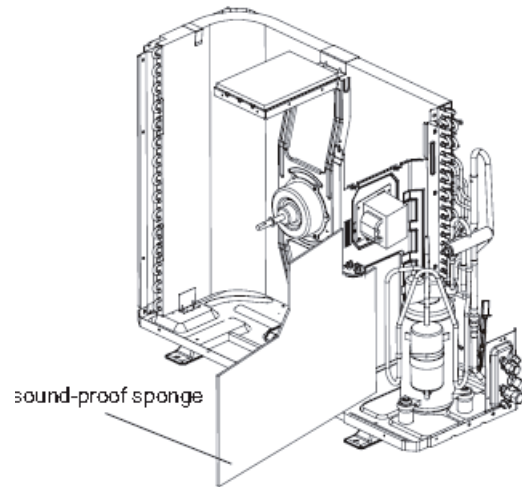

7. Remove isolation sheet

Remove screws attached to the isolation sheet and then remove the isolation sheet

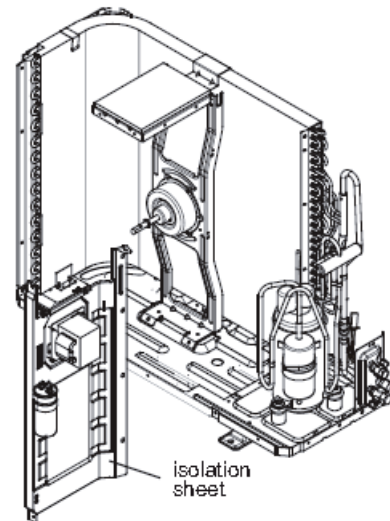

8. Remove gas and liquid valve

Remove the screws attached to the gas valve and unsolder the welding joint between the gas valve and the air-return pipe to remove the gas valve (NOTE: Discharge the refrigerant completely before un-soldering; When un-soldering, wrap the gas valve with a wet cloth completely to avoid damage to the valve cause by high temperature). Remove the screws attached to the liquid valve and unsolder the welding joint connecting the liquid valve to the Y-type pipe to remove the liquid valve.

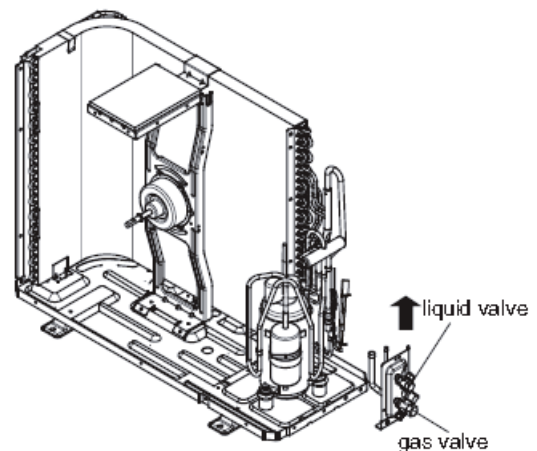

Disassembly of Outdoor Unit

18K 240 volt unit

Warning - Wait 10 minutes after power is disconnected before starting disassembly.

9. Remove 4-way valve

Discharge the refrigerant completely; unsolder the pipeline connecting the compressor and the condenser assembly, and then remove the 4-way valve.

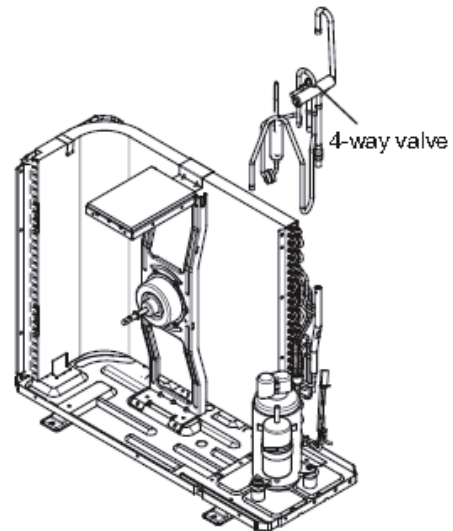

10. Remove compressor

Remove the nuts on the compressor feet and then remove the compressor.

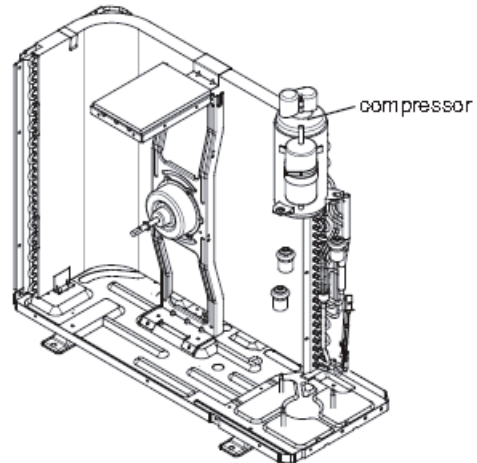

11. Remove motor and motor support

Remove the four tapping screws attached to the motor. Pull out the lead wire and remove the motor.

Remove the two tapping screws attached to the motor support. Lift motor support to remove it.

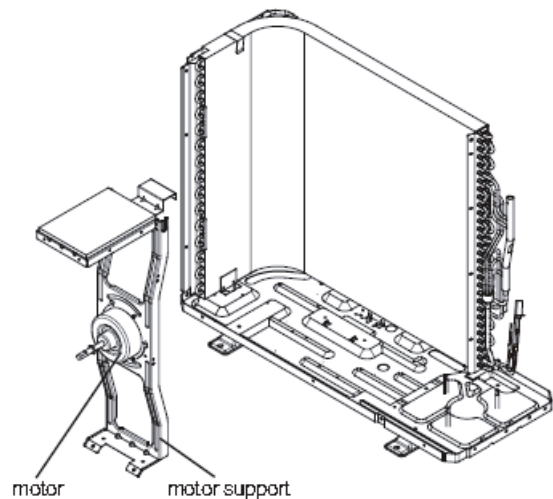

Disassembly of Outdoor Unit

24K 240 volt unit

Warning - Wait 10 minutes after power is disconnected before starting disassembly.

1. Remove handle and valve cover

Remove the screws used for attaching the handle, pull the handle upward to remove it. Loosen the screws attached to the valve cover and then remove it.

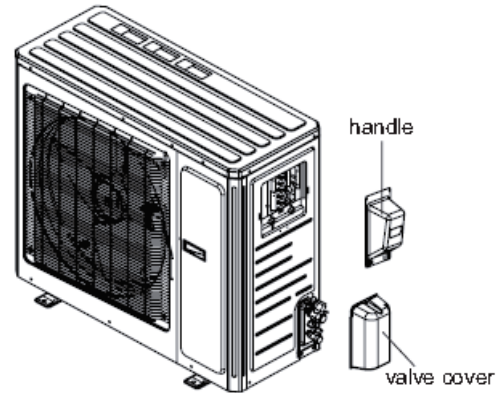

2 Remove top cover

Remove the connecting screws connecting the top cover plate with the front panel and the right side plate, and then remove the top cover.

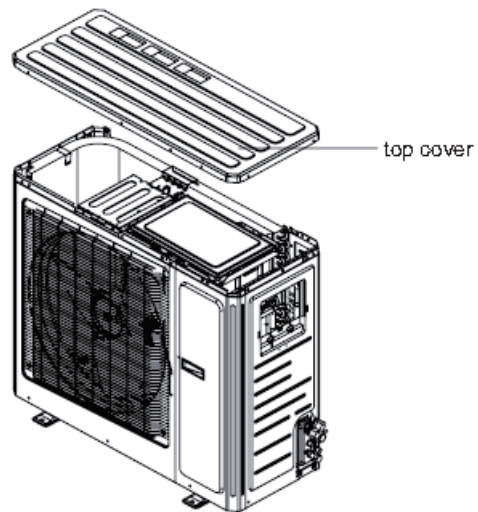

3. Remove front grille

Remove the screws connecting the front grille and front panel. Remove the front grille.

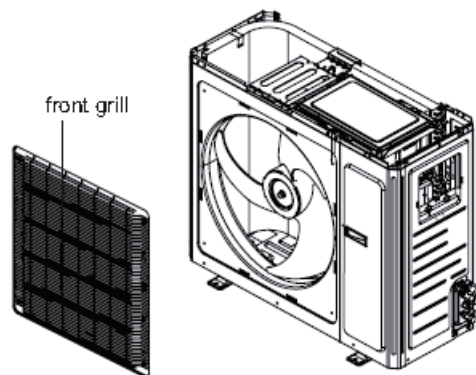

Disassembly of Outdoor Unit

24K 240 volt unit

Warning - Wait 10 minutes after power is disconnected before starting disassembly.

4. Remove front side plate and front pane

Remove screws connecting front side plate, outer case and chassis, and then remove the front side plate.

Remove screws connecting front panel, chassis and motor support, and then remove the front panel

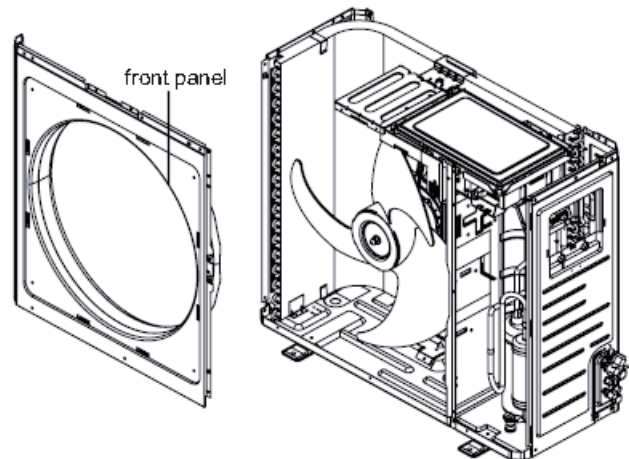
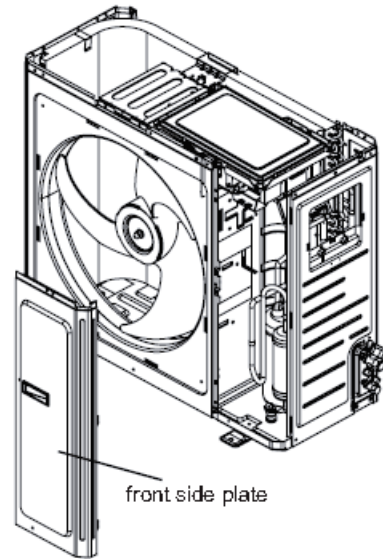

5. Remove right side plate

Remove screws connecting right side plate and chassis, valve support and condenser, and then remove the right side plate.

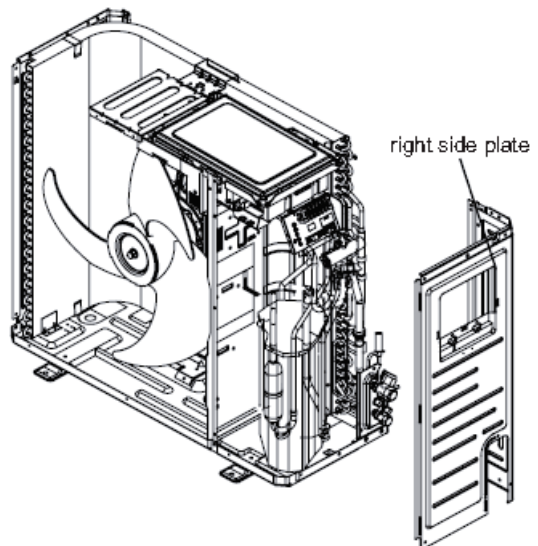

Disassembly of Outdoor Unit

24K 240 volt unit

Warning - Wait 10 minutes after power is disconnected before starting disassembly.

6. Remove axial flow fan blade

Remove nut on blade with wrench, and then remove the axial flow blade.

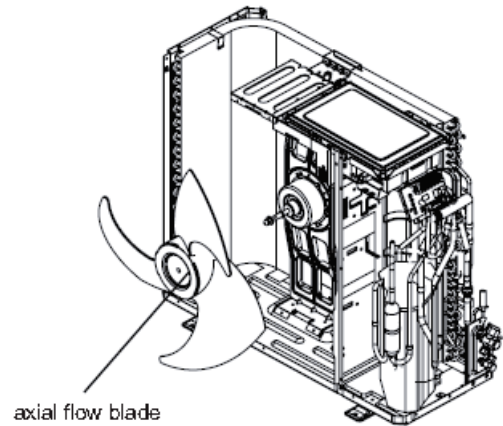

7. Remove electric box and shield

Remove screws connecting electric box, cut off the tie-line with scissors, pull out the wiring terminal and then lift up the electric box to remove it. Twist off the screws on fireproof electric box and then remove the fireproof electric box.

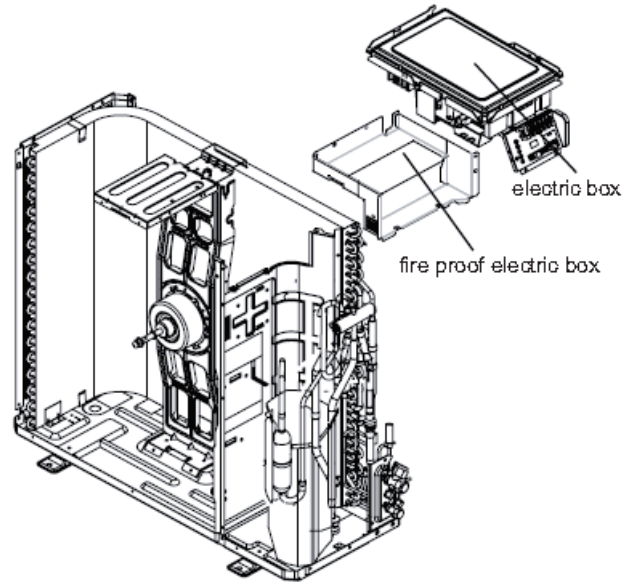

8. Remove motor and motor support

Remove the tapping screws connected to the motor, pull out the pin of leading wire for motor and then remove the motor.

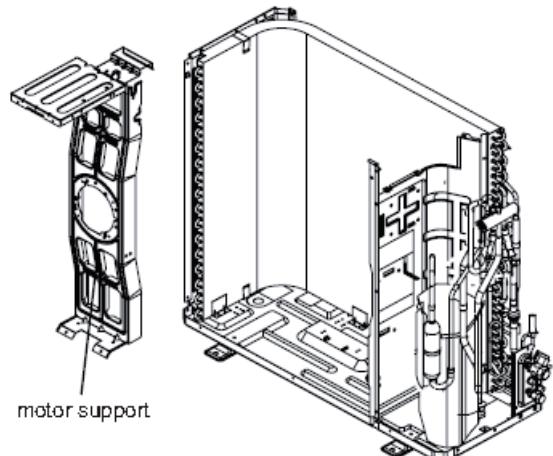

Disassembly of Outdoor Unit

24K 240 volt unit

Warning - Wait 10 minutes after power is disconnected before starting disassembly.

8. Remove motor and motor support, cont.

Remove the tapping screws attached to the motor support, pull it upwards and then remove the motor support.

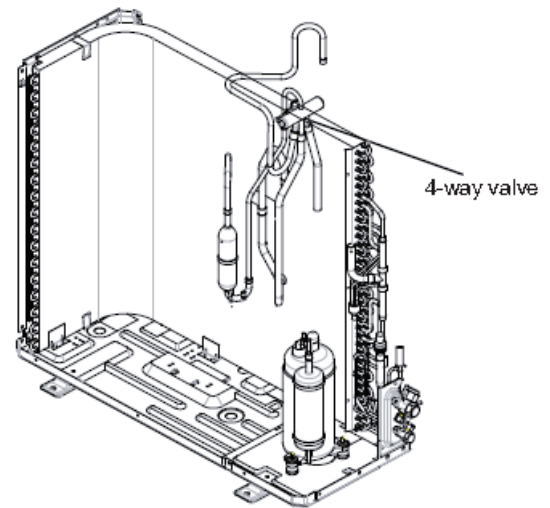

9. Remove isolation sheet

Remove the screws connecting isolation sheet and end plate of condenser and chassis, and then remove the isolation sheet.

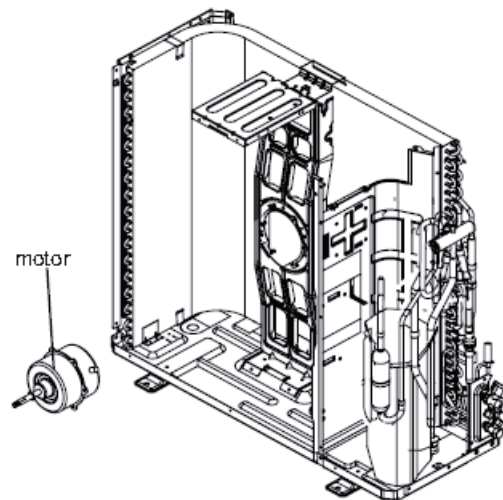

10. Remove 4-way valve

Unsolder the pipe line between compressor, condenser, gas and liquid valve. Then remove the 4-way valve (Note: release all refrigerant before un-soldering).

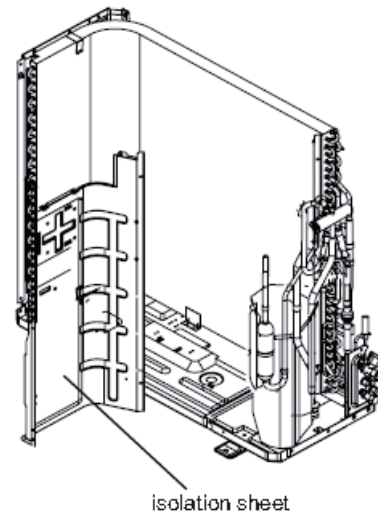

Disassembly of Outdoor Unit

24K 240 volt unit

Warning - Wait 10 minutes after power is disconnected before starting disassembly.

11. Remove gas and liquid valve

Remove the 2 bolts holding the valve sub-assy. Unsolder joint between gas valve and return pipe, then remove the gas line. (NOTE: Discharge the refrigerant completely before un-soldering; When un-soldering, wrap the gas valve with a wet cloth completely to avoid damage to the valve cause by high temperature). Remove the screws attached to the liquid valve and unsolder the welding joint connecting the liquid valve to the Y-type pipe to remove the liquid valve.

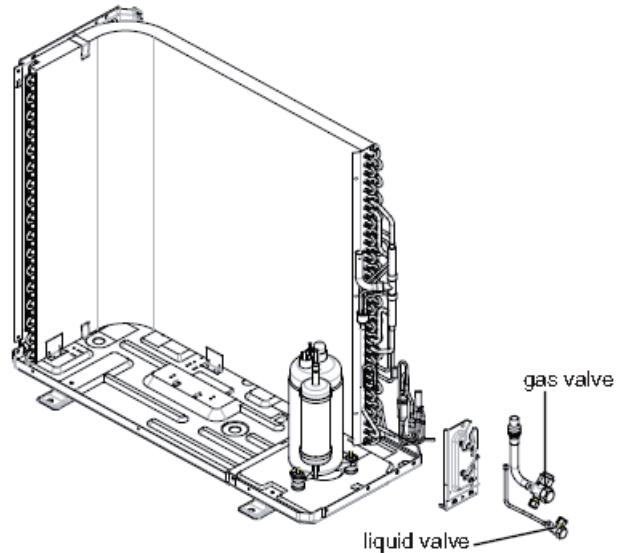

12. Remove compressor

Remove the three nuts on the compressor feet, then remove the compressor.

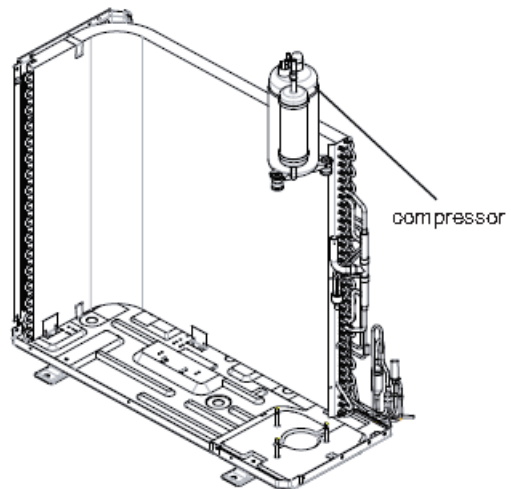

13. Remove left side plate

Remove the screws connecting the left side plate and chassis, then remove the left side plate.

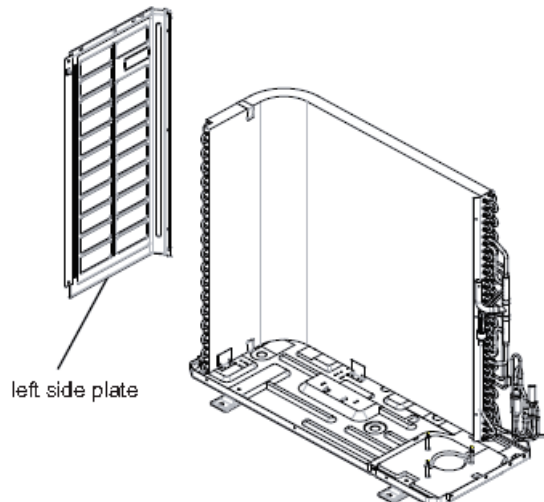

Disassembly of Indoor Unit

36K 240 volt unit shown, other models may vary slightly

Warning - Wait 10 minutes after power is disconnected before starting disassembly.

1. Before disassembly.

Assembled indoor unit.

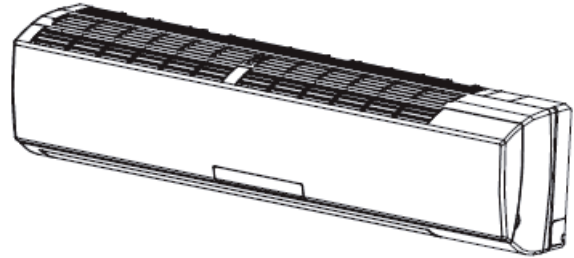

2 Remove filter

Open the panel

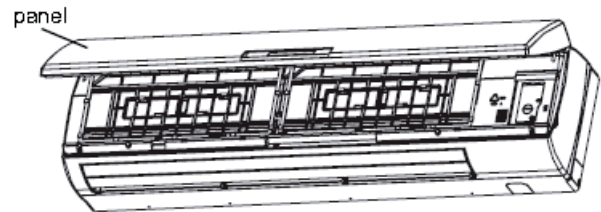

Loosen the clasps on the filter

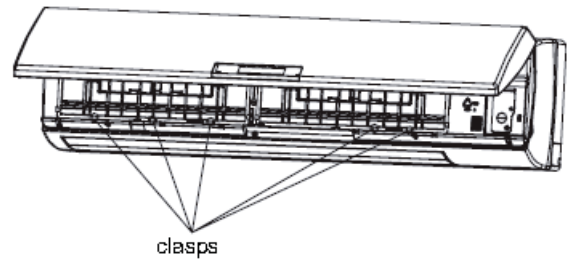

Remove filters

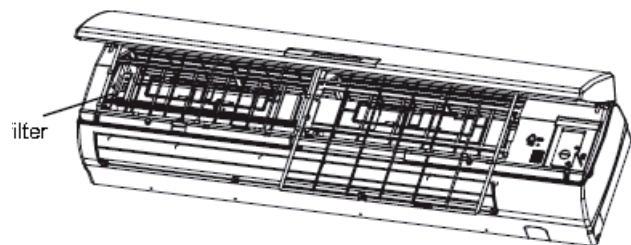

Disassembly of Indoor Unit

36K 240 volt unit shown, other models may vary slightly

Warning - Wait 10 minutes after power is disconnected before starting disassembly.

3. Remove display

Remove two screws attached to display, and then remove the display

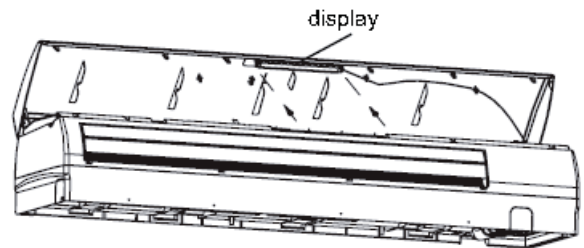

4. Remove panel

Pull the clasps at both sides slightly, and then remove the panel

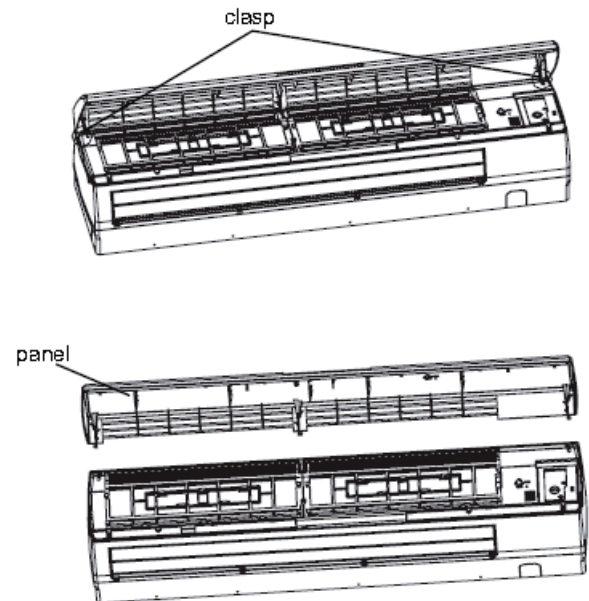

5. Remove horizontal louver

Remove the axial bush on the horizontal louver, and then remove the horizontal louver.

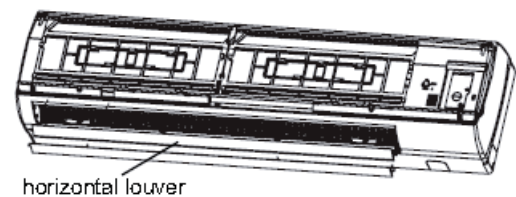

Disassembly of Indoor Unit

36K 240 volt unit shown, other models may vary slightly

Warning - Wait 10 minutes after power is disconnected before starting disassembly.

6. Remove top cover of electric box

Remove screws connecting the top cover of the electric box.

Remove the top cover of electric box.

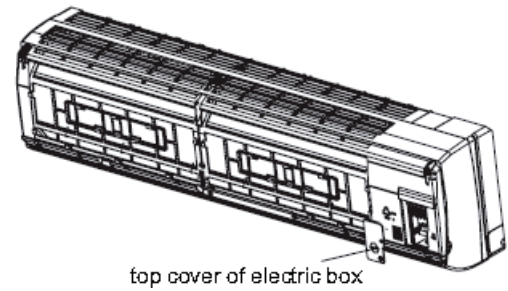
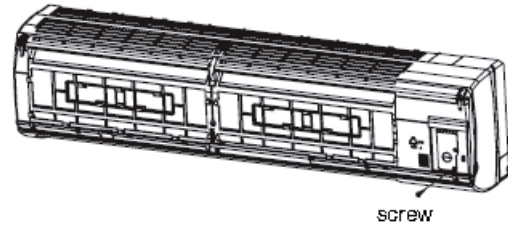

7 Remove front case

Remove the screw caps on front case.

Remove the screws connecting the front case.

Remove the front case

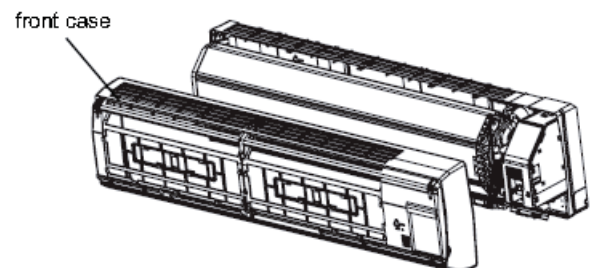
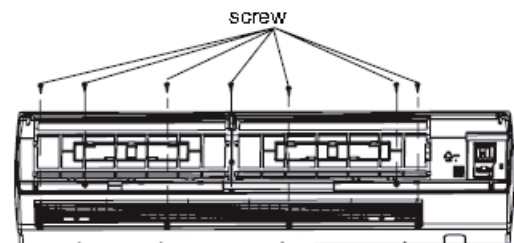
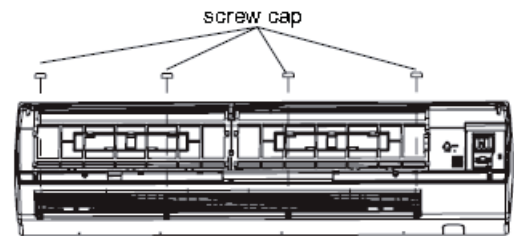

Disassembly of Indoor Unit

36K 240 volt unit shown, other models may vary slightly

Warning - Wait 10 minutes after power is disconnected before starting disassembly.

8. Remove ground wire

Remove grounding screws and then remove the grounding wire

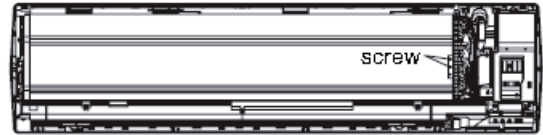

9. Remove electric box cover

Loosen clasps at the left side of electric box.

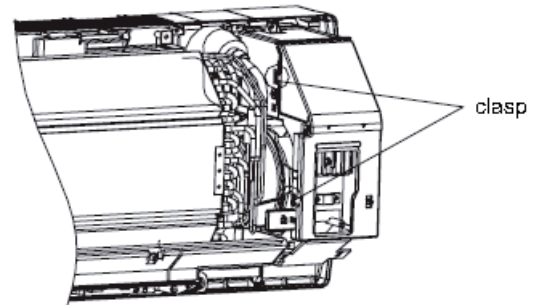

Loosen clasps on the right side of the electric box.

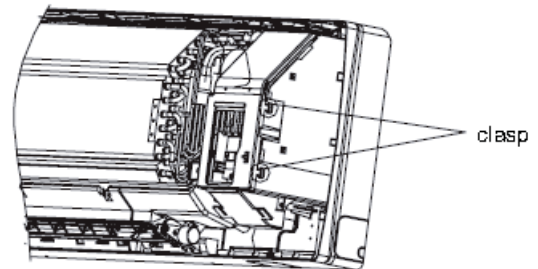

Remove electric box cover.

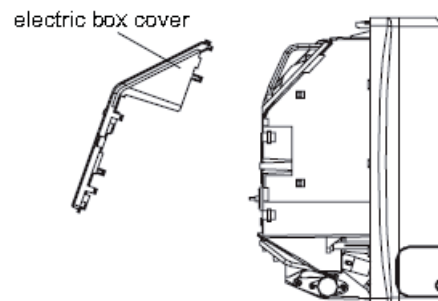

Disassembly of Indoor Unit

36K 240 volt unit shown, other models may vary slightly

Warning - Wait 10 minutes after power is disconnected before starting disassembly.

10. Remove temperature sensor

Pull out the indoor temperature sensor.

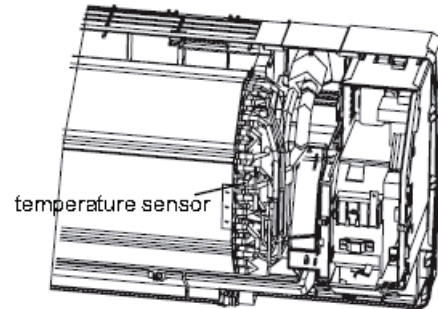

11. Remove electric box

Pull out six sockets on PCB board.

Pull out two screws on electric box.

Remove the electric box.

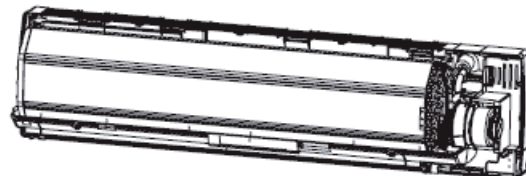
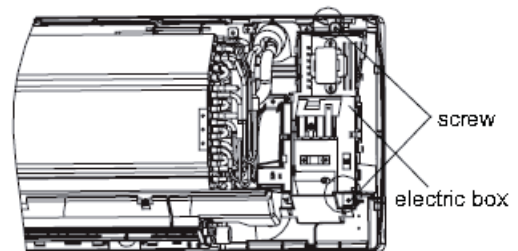
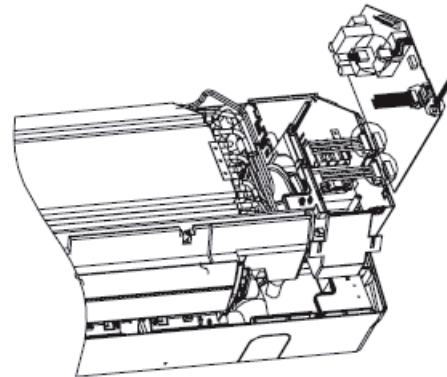

Disassembly of Indoor Unit

36K 240 volt unit shown, other models may vary slightly

Warning - Wait 10 minutes after power is disconnected before starting disassembly.

12. Remove display

Pull the water tray upwards and then remove the water tray.

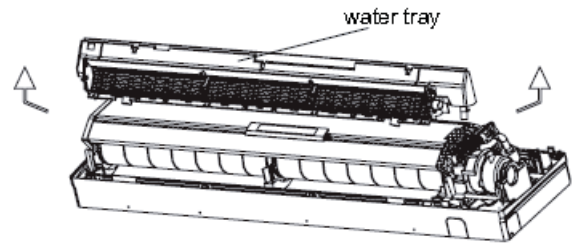

13. Remove panel

Separate the connection pipe between indoor and outdoor units.

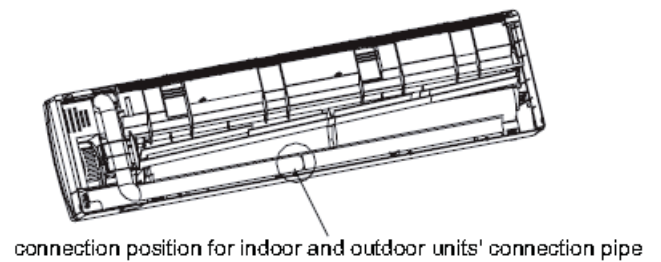

14. Remove horizontal louver

Remove two screws on pipe-stopping plate for indoor unit and then remove the pipe-stopping plate.

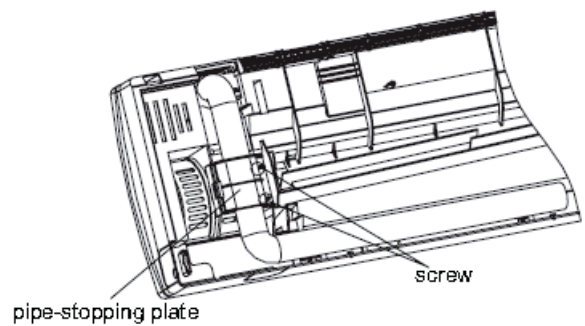

15. Remove damping board

Remove two screws on damping board, and then remove the damping board.

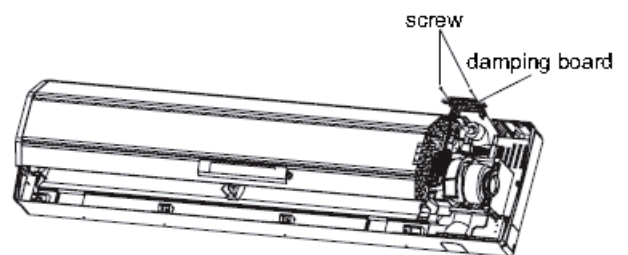

Disassembly of Indoor Unit

36K 240 volt unit shown, other models may vary slightly

Warning - Wait 10 minutes after power is disconnected before starting disassembly.

16. Remove evaporator

Remove screws between evaporator and bottom case.

Turn over the indoor unit and adjust the pipe line to the position as shown by the broken line.

Lift up the evaporator and then remove the evaporator.

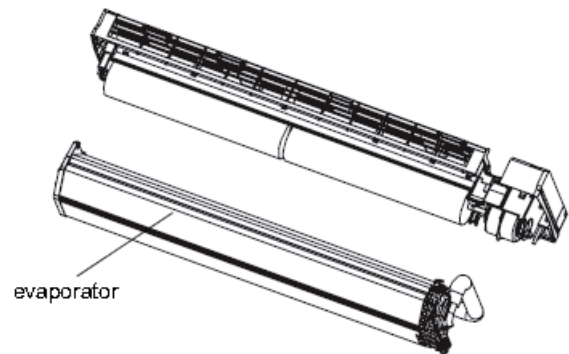
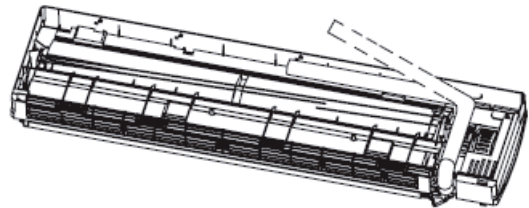
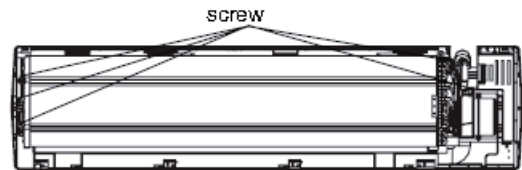

17 Remove motor bracket

Remove two screws on the motor connecting plate, and then remove the plate.

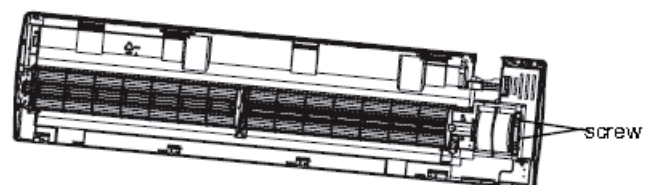

Disassembly of Indoor Unit

36K 240 volt unit shown, other models may vary slightly

Warning - Wait 10 minutes after power is disconnected before starting disassembly.

18. Remove cross flow blade and motor

Remove screws attached to cross flow blade and motor.

Remove the motor sub-assembly

Separate two cross flow blade.

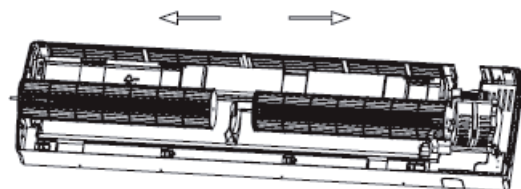
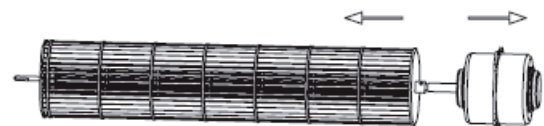
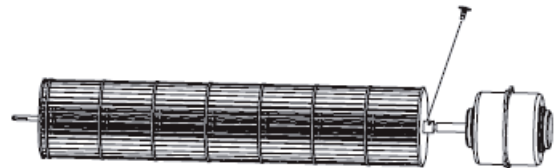
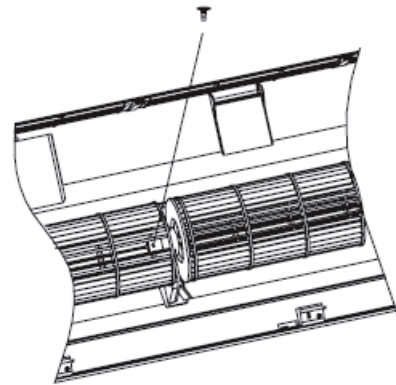
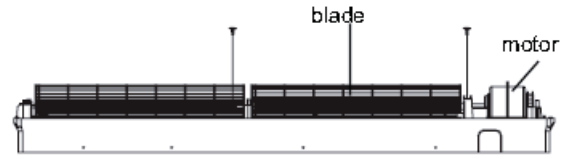

Disassembly of Indoor Unit

36K 240 volt unit shown, other models may vary slightly

Warning - Wait 10 minutes after power is disconnected before starting disassembly.

19. Remove temperature sensor

Remove the rubber cushion on the cross flow blade.

Remove the rubber cushion from the base.

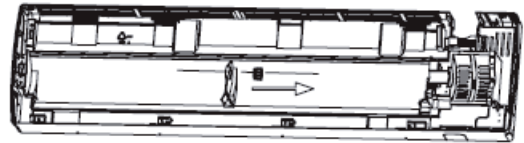
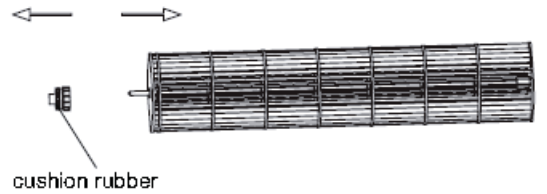

Disassembly of Outdoor Unit

36K 240 volt unit shown, other models may vary slightly

Warning - Wait 10 minutes after power is disconnected before starting disassembly.

1. Remove top cover and front side plate

Use the screwdriver to remove the screws connecting the top panel and side panels. Remove the top panel. Loosen the screws attached to the valve cover and then remove the valve cover.

Loosen the screws connecting the front side panel, mask, and chassis. Remove the front side panel.

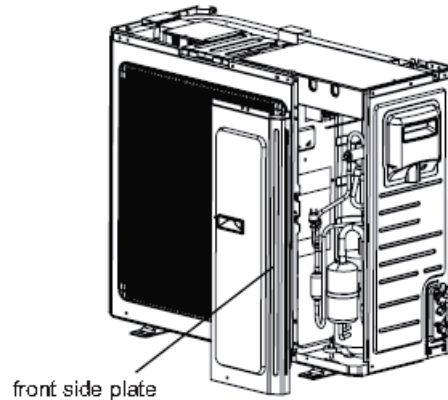
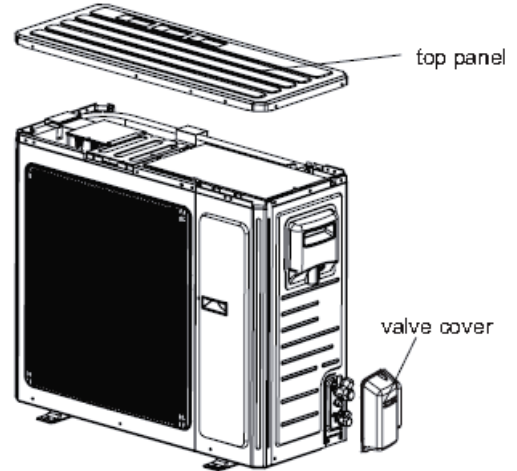

2. Remove grille

Remove the screws connecting the grille and panel and then remove the grille.

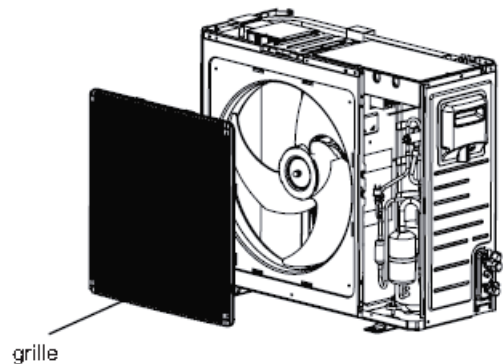

Disassembly of Outdoor Unit

36K 240 volt unit shown, other models may vary slightly

Warning - Wait 10 minutes after power is disconnected before starting disassembly.

3. Remove panel

Remove the screws connecting the panel, chassis and motor support with a screwdriver, and then remove the panel.

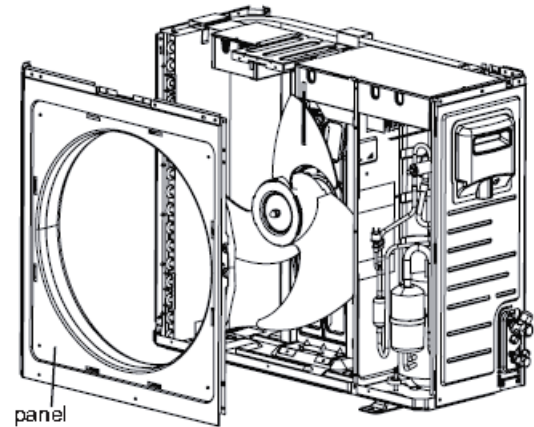

4. Remove guard grille

Remove the screws connected to the guard grille and then remove the guard grille.

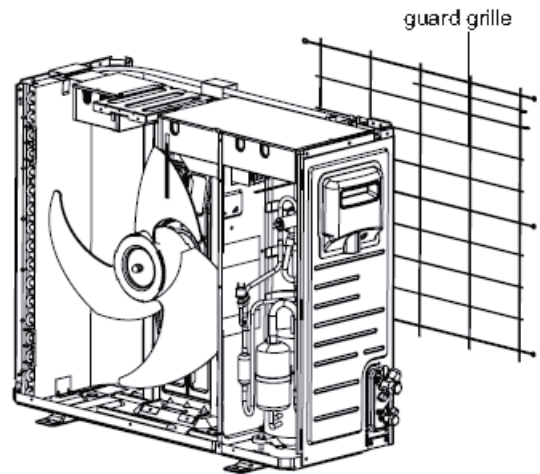

5. Remove handle

Remove the screws connected to the handle and then remove the handle.

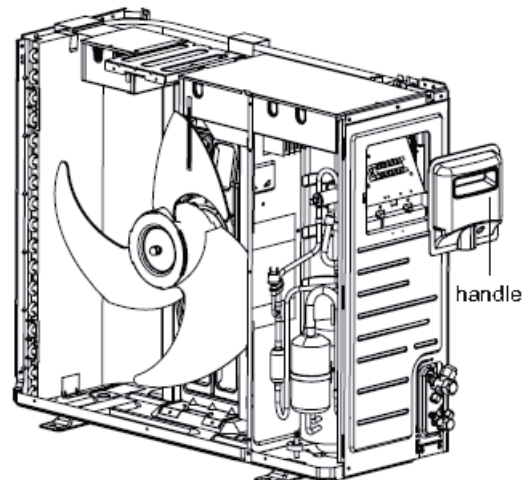

Disassembly of Outdoor Unit

36K 240 volt unit shown, other models may vary slightly

Warning - Wait 10 minutes after power is disconnected before starting disassembly.

6. Remove right side plate

Remove the screws connecting the right side plate and chassis, valve support and condenser, and then remove the right side plate.

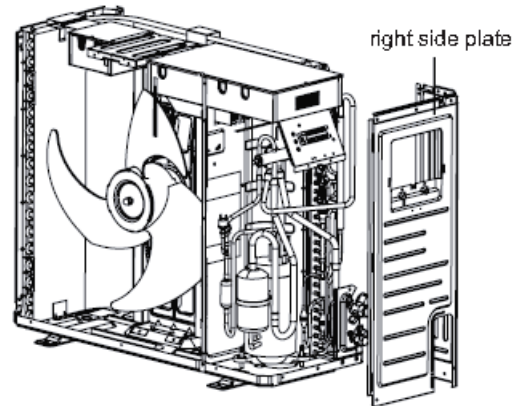

7. Remove electric box

Remove the screws on electric box cover with a screwdriver, and then remove the electric box cover

Remove the screws on the electric box, cut off the tie-line with scissors or pliers, pull out the wiring terminal and pull it upwards to remove the electric box.

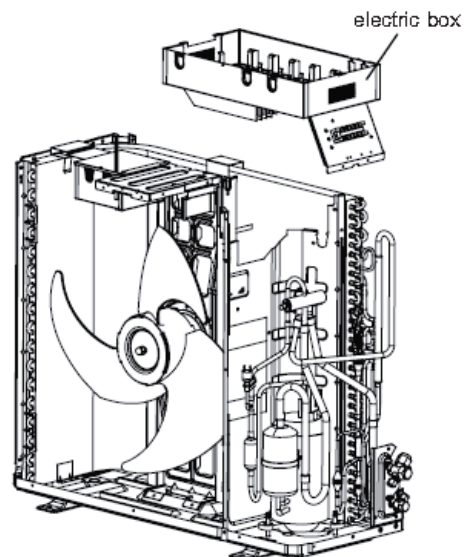
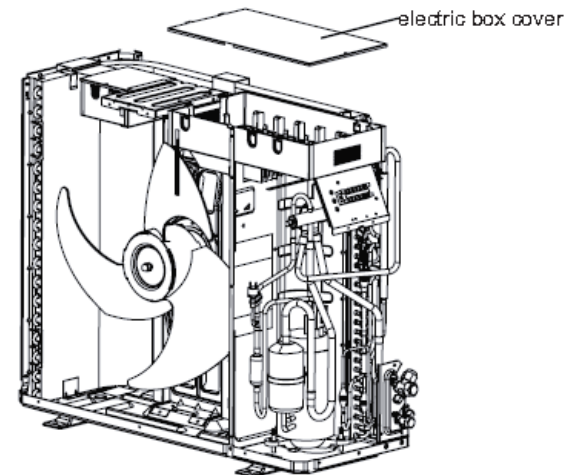

Disassembly of Outdoor Unit

36K 240 volt unit shown, other models may vary slightly

Warning - Wait 10 minutes after power is disconnected before starting disassembly.

7. Remove electric box, cont.

Remove the screws between electric box “1” and left side plate with screwdriver, pull it upwards to remove the electric box “1”.

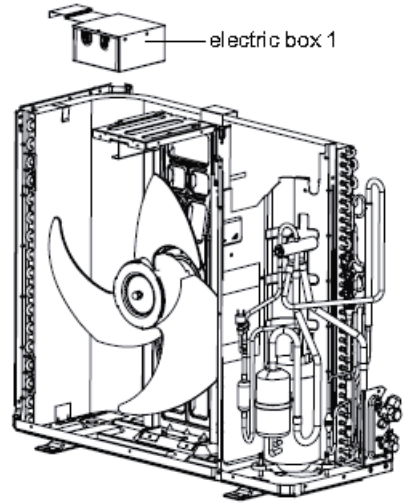

8. Remove left side plate

Remove the screws connecting the left side plate and chassis with screwdriver, and then remove the left side plate.

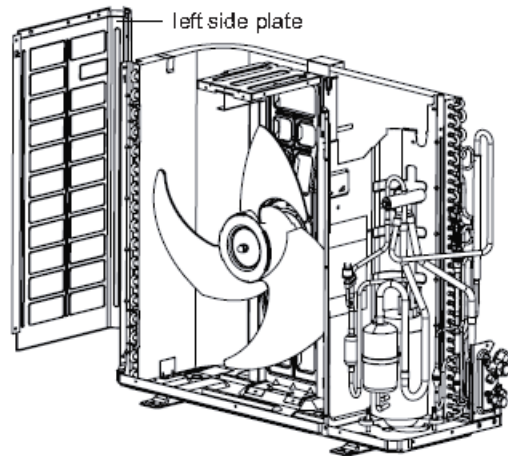

9. Remove axial flow blade

Remove the nuts on blade with a wrench and then remove the axial flow blade.

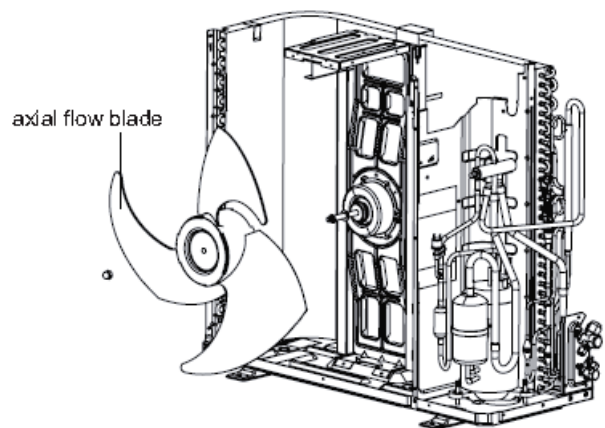

Disassembly of Outdoor Unit

36K 240 volt unit shown, other models may vary slightly

Warning - Wait 10 minutes after power is disconnected before starting disassembly.

10. Remove motor and motor support

Remove the tapping screws fixing the motor, pull out the pin of leading wire for motor and then remove the motor.

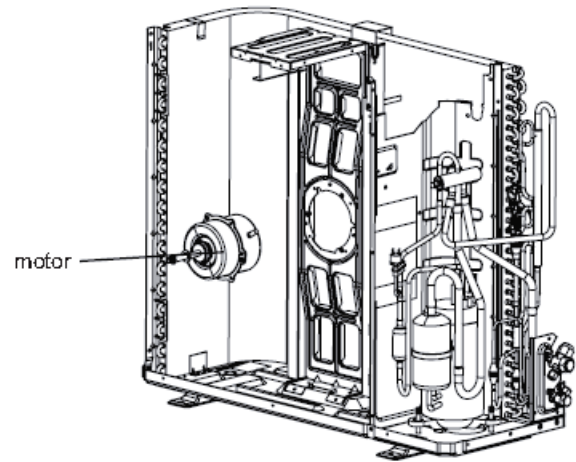

Remove the tapping screws fixing the motor support, pull it upwards and then remove the motor support.

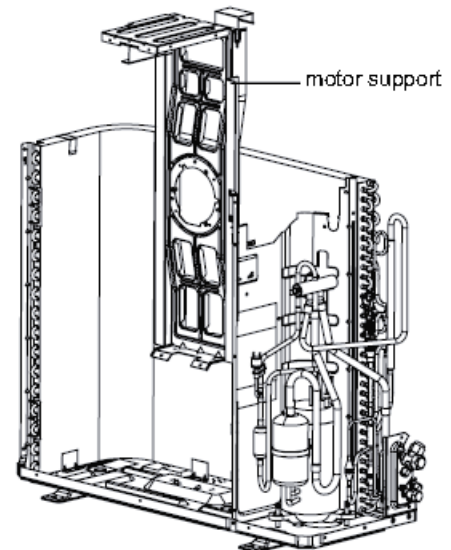

11. Remove 4-way valve

Unsolder the pipeline between compressor, condenser, gas and liquid valve, and then remove the 4-way valve (Note: Release all refrigerant before un-soldering).

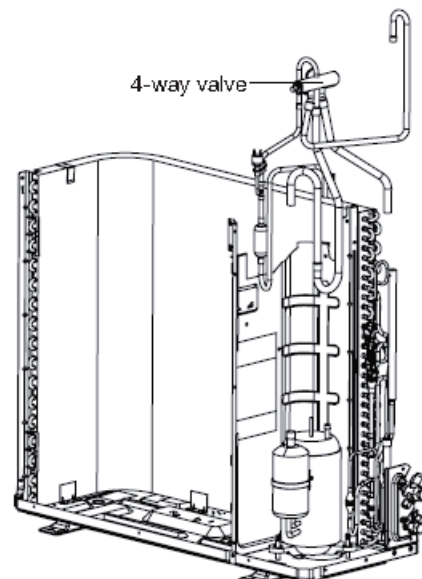

Disassembly of Outdoor Unit

36K 240 volt unit shown, other models may vary slightly

Warning - Wait 10 minutes after power is disconnected before starting disassembly.

12. Remove gas and liquid valve

Remove the two bolts holding the valve sub assembly. Unsolder the solder joint between gas valve and air-return pipe and then remove the gas valve (Note: when un-soldering the soldering joint, wrap the gas valve with wet cloth completely to avoid the damage to valve, and release all refrigerant completely at first). Unsolder the soldering joint between liquid valve and connection pipe of liquid valve, and then remove the liquid valve.

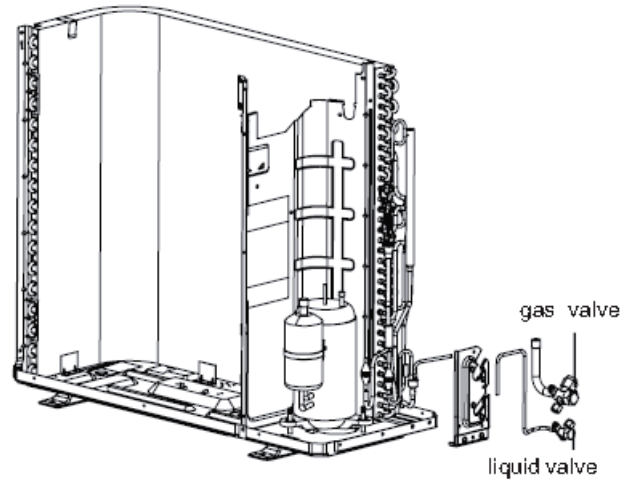

13. Remove compressor

Remove the three foot-nuts on the compressor and then remove the compressor.

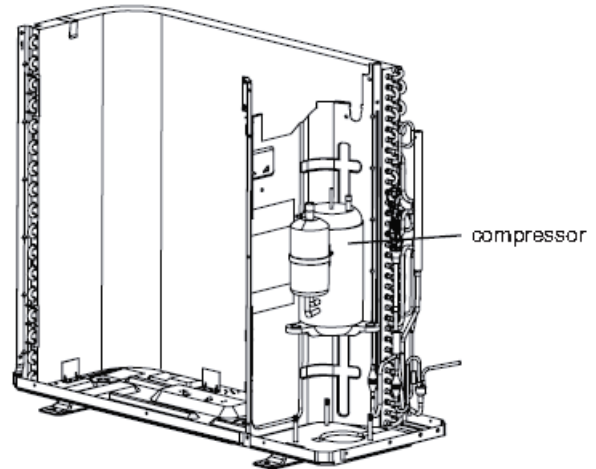

14. Remove isolation sheet

Remove the screws connecting isolation sheet and end plate of condenser and chassis, and then remove the isolation sheet.

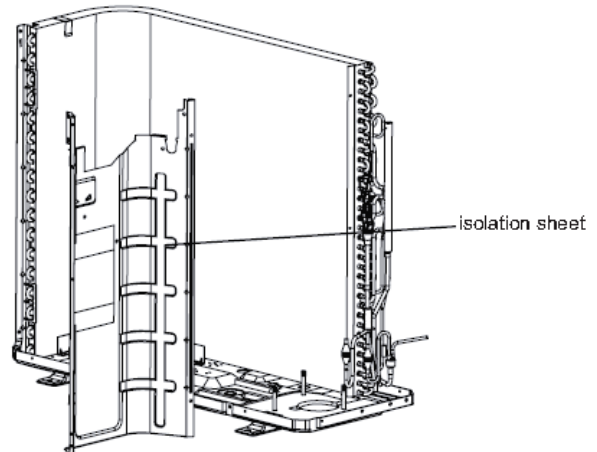

Disassembly of Outdoor Unit

36K 240 volt unit shown, other models may vary slightly

Warning - Wait 10 minutes after power is disconnected before starting disassembly.

15. Remove motor and motor support

Remove the screws connecting the support plate of condenser and condenser with screwdriver, and then remove the support plate of condenser.

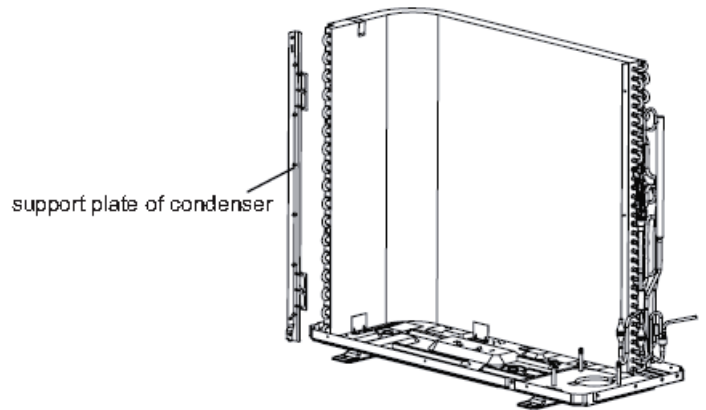

16. Remove 4-way valve

Pull it upwards to separate the chassis and condenser.

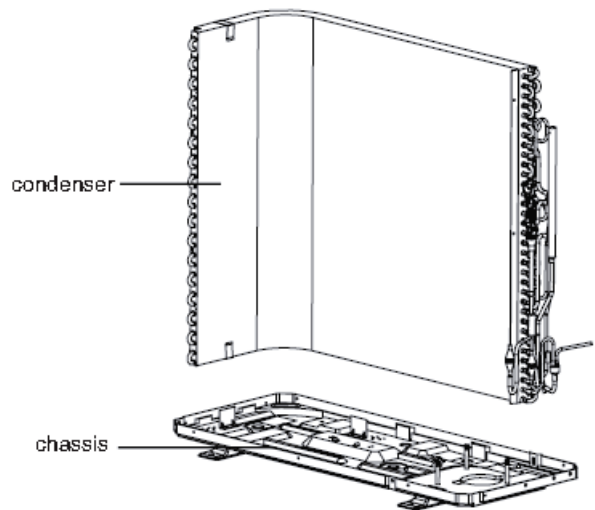

Appendix 1: Resistance Table of Ambient Temperature Sensor for Indoor and Outdoor Units (15K)

Temp (°C)	Temp (°F)	Resistance (kΩ)		Temp (°C)	Temp (°F)	Resistance (kΩ)		Temp (°C)	Temp (°F)	Resistance (kΩ)
-19	-2.2	138.1		33	91.4	10.63		85	185.0	1.594
-18	-0.4	128.6		34	93.2	10.2		86	186.8	1.544
-17	1.4	121.6		35	95.0	9.779		87	188.6	1.497
-16	3.2	115		36	96.8	9.382		88	190.4	1.451
-15	5.0	108.7		37	98.6	9.003		89	192.2	1.408
-14	6.8	102.9		38	100.4	8.642		90	194.0	1.363
-13	8.6	97.4		39	102.2	8.297		91	195.8	1.322
-12	10.4	92.22		40	104.0	7.967		92	197.6	1.282
-11	12.2	87.35		41	105.8	7.653		93	199.4	1.244
-10	14.0	82.75		42	107.6	7.352		94	201.2	1.207
-9	15.8	78.43		43	109.4	7.065		95	203.0	1.171
-8	17.6	74.35		44	111.2	6.791		96	204.8	1.136
-7	19.4	70.5		45	113.0	6.529		97	206.6	1.103
-6	21.2	66.88		46	114.8	6.278		98	208.4	1.071
-5	23.0	63.46		47	116.6	6.038		99	210.2	1.039
-4	24.8	60.23		48	118.4	5.809		100	212.0	1.009
-3	26.6	57.18		49	120.2	5.589		101	213.8	0.98
-2	28.4	54.31		50	122.0	5.379		102	215.6	0.952
-1	30.2	51.59		51	123.8	5.197		103	217.4	0.925
0	32.0	49.02		52	125.6	4.986		104	219.2	0.898
1	33.8	46.6		53	127.4	4.802		105	221.0	0.873
2	35.6	44.31		54	129.2	4.625		106	222.8	0.848
3	37.4	42.14		55	131.0	4.456		107	224.6	0.825
4	39.2	40.09		56	132.8	4.294		108	226.4	0.802
5	41.0	38.15		57	134.6	4.139		109	228.2	0.779
6	42.8	36.32		58	136.4	3.99		110	230.0	0.758
7	44.6	34.58		59	138.2	3.848		111	231.8	0.737
8	46.4	32.94		60	140.0	3.711		112	233.6	0.717
9	48.2	31.38		61	141.8	3.579		113	235.4	0.697

Appendix 1: Resistance Table of Ambient Temperature Sensor for Indoor and Outdoor Units (15K)

Temp (°C)	Temp (°F)	Resistance (kΩ)		Temp (°C)	Temp (°F)	Resistance (kΩ)		Temp (°C)	Temp (°F)	Resistance (kΩ)
10	50.0	29.9		62	143.6	3.454		114	237.2	0.678
11	51.8	28.51		63	145.4	3.333		115	239.0	0.66
12	53.6	27.18		64	147.2	3.217		116	240.8	0.642
13	55.4	25.92		65	149.0	3.105		117	242.6	0.625
14	57.2	24.73		66	150.8	2.998		118	244.4	0.608
15	59.0	23.6		67	152.6	2.896		119	246.2	0.592
16	60.8	22.53		68	154.4	2.797		120	248.0	0.577
17	62.6	21.51		69	156.2	2.702		121	249.8	0.561
18	64.4	20.54		70	158.0	2.611		122	251.6	0.547
19	66.2	19.63		71	159.8	2.523		123	253.4	0.532
20	68.0	18.75		72	161.6	2.439		124	255.2	0.519
21	69.8	17.93		73	163.4	2.358		125	257.0	0.505
22	71.6	17.14		74	165.2	2.28		126	258.8	0.492
23	73.4	16.39		75	167.0	2.206		127	260.6	0.48
24	75.2	15.68		76	168.8	2.133		128	262.4	0.467
25	77.0	15		77	170.6	2.064		129	264.2	0.456
26	78.8	14.36		78	172.4	1.997		130	266.0	0.44
27	80.6	13.74		79	174.2	1.933		131	267.8	0.433
28	82.4	13.16		80	176.0	1.871		132	269.6	0.422
29	84.2	12.6		81	177.8	1.811		133	271.4	0.412
30	86.0	12.07		82	179.6	1.754		134	273.2	0.401
31	87.8	11.57		83	181.4	1.699		135	275.0	0.391

Appendix 2: Resistance Table of Outdoor and Indoor Tube Temperature Sensors (20K)

Temp (°C)	Temp (°F)	Resistance (kΩ)		Temp (°C)	Temp (°F)	Resistance (kΩ)		Temp (°C)	Temp (°F)	Resistance (kΩ)
-19	-2.2	181.4		33	91.4	14.18		85	185.0	2.125
-18	-0.4	171.4		34	93.2	13.59		86	186.8	2.059
-17	1.4	162.1		35	95.0	13.04		87	188.6	1.996
-16	3.2	153.3		36	96.8	12.51		88	190.4	1.934
-15	5.0	145		37	98.6	12		89	192.2	1.875
-14	6.8	137.2		38	100.4	11.52		90	194.0	1.818
-13	8.6	129.9		39	102.2	11.06		91	195.8	1.736
-12	10.4	123		40	104.0	10.62		92	197.6	1.71
-11	12.2	116.5		41	105.8	10.2		93	199.4	1.658
-10	14.0	110.3		42	107.6	9.803		94	201.2	1.609
-9	15.8	104.6		43	109.4	9.42		95	203.0	1.561
-8	17.6	99.13		44	111.2	9.054		96	204.8	1.515
-7	19.4	94		45	113.0	8.705		97	206.6	1.47
-6	21.2	89.17		46	114.8	8.37		98	208.4	1.427
-5	23.0	84.61		47	116.6	8.051		99	210.2	1.386
-4	24.8	80.31		48	118.4	7.745		100	212.0	1.346
-3	26.6	76.24		49	120.2	7.453		101	213.8	1.307
-2	28.4	72.41		50	122.0	7.173		102	215.6	1.269
-1	30.2	68.79		51	123.8	6.905		103	217.4	1.233
0	32.0	65.37		52	125.6	6.648		104	219.2	1.198
1	33.8	62.13		53	127.4	6.403		105	221.0	1.164
2	35.6	59.08		54	129.2	6.167		106	222.8	1.131
3	37.4	56.19		55	131.0	5.942		107	224.6	1.099
4	39.2	53.46		56	132.8	5.726		108	226.4	1.069
5	41.0	50.87		57	134.6	5.519		109	228.2	1.039
6	42.8	48.42		58	136.4	5.32		110	230.0	1.01
7	44.6	46.11		59	138.2	5.13		111	231.8	0.983
8	46.4	43.92		60	140.0	4.948		112	233.6	0.956
9	48.2	41.84		61	141.8	4.773		113	235.4	0.93

Appendix 2: Resistance Table of Outdoor and Indoor Tube Temperature Sensors (20K)

Temp (°C)	Temp (°F)	Resistance (kΩ)		Temp (°C)	Temp (°F)	Resistance (kΩ)		Temp (°C)	Temp (°F)	Resistance (kΩ)
10	50.0	39.87		62	143.6	4.605		114	237.2	0.904
11	51.8	38.01		63	145.4	4.443		115	239.0	0.88
12	53.6	36.24		64	147.2	4.289		116	240.8	0.856
13	55.4	34.57		65	149.0	4.14		117	242.6	0.833
14	57.2	32.98		66	150.8	3.998		118	244.4	0.811
15	59.0	31.47		67	152.6	3.861		119	246.2	0.77
16	60.8	30.04		68	154.4	3.729		120	248.0	0.769
17	62.6	28.68		69	156.2	3.603		121	249.8	0.746
18	64.4	27.39		70	158.0	3.481		122	251.6	0.729
19	66.2	26.17		71	159.8	3.364		123	253.4	0.71
20	68.0	25.01		72	161.6	3.252		124	255.2	0.692
21	69.8	23.9		73	163.4	3.144		125	257.0	0.674
22	71.6	22.85		74	165.2	3.04		126	258.8	0.658
23	73.4	21.85		75	167.0	2.94		127	260.6	0.64
24	75.2	20.9		76	168.8	2.844		128	262.4	0.623
25	77.0	20		77	170.6	2.752		129	264.2	0.607
26	78.8	19.14		78	172.4	2.663		130	266.0	0.592
27	80.6	18.13		79	174.2	2.577		131	267.8	0.577
28	82.4	17.55		80	176.0	2.495		132	269.6	0.563
29	84.2	16.8		81	177.8	2.415		133	271.4	0.549
30	86.0	16.1		82	179.6	2.339		134	273.2	0.535
31	87.8	15.43		83	181.4	2.265		135	275.0	0.521
32	89.6	14.79		84	183.2	2.194		136	276.8	0.509

Appendix 3: Resistance Table of Outdoor Discharge Temperature Sensor (50K)

Temp (°C)	Temp (°F)	Resistance (kΩ)		Temp (°C)	Temp (°F)	Resistance (kΩ)		Temp (°C)	Temp (°F)	Resistance (kΩ)
-29	-20.2	853.5		23	73.4	53.74		75	167.0	7.224
-28	-18.4	799.8		24	75.2	51.41		76	168.8	6.998
-27	-16.6	750		25	77.0	49.19		77	170.6	6.761
-26	-14.8	703.8		26	78.8	47.08		78	172.4	6.542
-25	-13.0	660.8		27	80.6	45.07		79	174.2	6.331
-24	-11.2	620.8		28	82.4	43.16		80	176.0	6.129
-23	-9.4	580.6		29	84.2	41.34		81	177.8	5.933
-22	-7.6	548.9		30	86.0	39.61		82	179.6	5.746
-21	-5.8	516.6		31	87.8	37.96		83	181.4	5.565
-20	-4.0	486.5		32	89.6	36.38		84	183.2	5.39
-19	-2.2	458.3		33	91.4	34.88		85	185.0	5.22
-18	-0.4	432		34	93.2	33.45		86	186.8	5.06
-17	1.4	407.4		35	95.0	32.09		87	188.6	4.904
-16	3.2	384.5		36	96.8	30.79		88	190.4	4.754
-15	5.0	362.9		37	98.6	29.54		89	192.2	4.609
-14	6.8	342.8		38	100.4	28.36		90	194.0	4.469
-13	8.6	323.9		39	102.2	27.23		91	195.8	4.334
-12	10.4	306.2		40	104.0	26.15		92	197.6	4.204
-11	12.2	289.6		41	105.8	25.11		93	199.4	4.079
-10	14.0	274		42	107.6	24.13		94	201.2	3.958
-9	15.8	259.3		43	109.4	23.19		95	203.0	3.841
-8	17.6	245.6		44	111.2	22.29		96	204.8	3.728
-7	19.4	232.6		45	113.0	21.43		97	206.6	3.619
-6	21.2	220.5		46	114.8	20.6		98	208.4	3.514
-5	23.0	209		47	116.6	19.81		99	210.2	3.413
-4	24.8	198.3		48	118.4	19.06		100	212.0	3.315
-3	26.6	199.1		49	120.2	18.34		101	213.8	3.22
-2	28.4	178.5		50	122.0	17.65		102	215.6	3.129
-1	30.2	169.5		51	123.8	16.99		103	217.4	3.04
0	32.0	161		52	125.6	16.36		104	219.2	2.955
1	33.8	153		53	127.4	15.75		105	221.0	2.872
2	35.6	145.4		54	129.2	15.17		106	222.8	2.792
3	37.4	138.3		55	131.0	14.62		107	224.6	2.715
4	39.2	131.5		56	132.8	14.09		108	226.4	2.64

Appendix 3: Resistance Table of Outdoor Discharge Temperature Sensor (50K)

Temp (°C)	Temp (°F)	Resistance (kΩ)		Temp (°C)	Temp (°F)	Resistance (kΩ)		Temp (°C)	Temp (°F)	Resistance (kΩ)
5	41.0	125.1		57	134.6	13.58		109	228.2	2.568
6	42.8	119.1		58	136.4	13.09		110	230.0	2.498
7	44.6	113.4		59	138.2	12.62		111	231.8	2.431
8	46.4	108		60	140.0	12.17		112	233.6	2.365
9	48.2	102.8		61	141.8	11.74		113	235.4	2.302
10	50.0	98		62	143.6	11.32		114	237.2	2.241
11	51.8	93.42		63	145.4	10.93		115	239.0	2.182
12	53.6	89.07		64	147.2	10.54		116	240.8	2.124
13	55.4	84.95		65	149.0	10.18		117	242.6	2.069
14	57.2	81.05		66	150.8	9.827		118	244.4	2.015
15	59.0	77.35		67	152.6	9.489		119	246.2	1.963
16	60.8	73.83		68	154.4	9.165		120	248.0	1.912
17	62.6	70.5		69	156.2	8.854		121	249.8	1.863
18	64.4	67.34		70	158.0	8.555		122	251.6	1.816
19	66.2	64.33		71	159.8	8.268		123	253.4	1.77
20	68.0	61.48		72	161.6	7.991		124	255.2	1.725
21	69.8	58.77		73	163.4	7.726		125	257.0	1.682
22	71.6	56.19		74	165.2	7.47		126	258.8	1.64

