



Terra

DUCTLESS SYSTEM

Installation, Service & Troubleshooting

Models:

TERRA09HP230V1A

TERRA12HP230V1A

TERRA18HP230V1A

TERRA24HP230V1A

Table of Contents

Safety Precautions & Warnings.....	3
Model Number Identification.....	4
Physical & Electrical Data.....	5 - 6
Product Introduction (System Overview).....	7
Product Introduction (Refrigeration Cycles).....	8 - 10
Indoor & Outdoor Components.....	11 - 12
Operational Data.....	13- 16
Basic Functions 9,000/12,000 btuh Systems.....	17 - 28
Basic Functions 18,000/24,000 btuh Systems.....	29 - 41
Remote Control Operation.....	42 - 43
Refrigerant Lines, Connection, Evacuating and Charging.....	44 - 46
Installation.....	47 - 51
Filter Maintenance and Emergency Operation.....	52
Electrical Schematics.....	53 - 59
Troubleshooting Outdoor Components.....	60 - 65
Fault & Status Displays.....	66 - 75
Error Code Diagnostics.....	76 - 95
Disassembly of Indoor Unit 9,000/12,000 btuh Models.....	96 - 103
Disassembly of Indoor Unit 18,000 btuh Model.....	104 - 111
Disassembly of Indoor Unit 24,000 btuh Model.....	112 - 118
Disassembly of Outdoor Unit 9,000/12,000 btuh Models.....	119 - 121
Disassembly of Outdoor Unit 18,000 btuh Models.....	122 - 124
Disassembly of Outdoor Unit 24,000 btuh Models.....	125 - 128
Appendix 1 - 3 Temperature Sensor Resistance Tables.....	129 - 134

Safety Precautions & Warnings



Warning

Installing, starting up, and servicing air conditioner can be hazardous due to system pressure, electrical components, and equipment location, etc. Only trained, qualified installers and service personnel are allowed to install, start-up, and service this equipment. Untrained personnel can perform basic maintenance functions such as cleaning coils. All other operations should be performed by trained service personnel. When handling the equipment, observe precautions in the manual and on tags, stickers, and labels attached to the equipment. Follow all safety codes. Wear safety glasses and work gloves. Keep quenching cloth and fire extinguisher nearby when brazing. Read the instructions thoroughly and follow all warnings or cautions in literature and attached to the unit. Consult local building codes and current editions of national as well as local electrical codes.

Recognize the following safety information:



Warning: Incorrect handling could result in personal injury or death.



Caution: Incorrect handling may result in minor injury, or damage to product or property.



Warning

All electrical work must be performed by a qualified, licensed electrician according to local and national codes as well as the instructions provided in the manual.

- Before installing, modifying, or servicing the system, the main electrical disconnect must be off. There may be more than one disconnect switch. Lock out and tag switch with a suitable warning label.
- Never supply power to the unit unless all wiring and tubing are completed, reconnected and checked.
- This system adopts highly dangerous electrical voltage. Incorrect connections or inadequate grounding can cause personal injury or death. Refer to your local and national codes for proper grounding.
- Have the unit properly grounded with all connections tight. Loose connections can cause overheating and a possible fire hazard.



Caution

- Never install the unit in a place where a combustible gas might leak, or it may lead to fire or explosion.
- Make a proper provision against noise when the unit is installed at a telecommunication center or hospital.
- Provide a GFIC circuit when the local or national electric code requires it.
- Never wash the unit with water.
- Handle unit transportation with care. Use two people when the weight exceeds the capacity for one person.
- Never touch the heat exchanger fins with bare hands, sharp edges could cause personal injury.
- Never touch the compressor or refrigerant tubing without proper hand protection.
- Do not operate the unit without the air filters in place.
- Should any emergency occur, stop the unit and disconnect the electrical supply.
- Properly insulate tubing running inside the room to prevent water damage from condensation.



Warning

All installation or repair work shall be performed by your dealer or a specialized subcontractor as there is the risk of fire, electric shock, explosion or injury



Warning

Pressurized Refrigerant

Personal injury could result in failure to follow this warning. System contain oil and refrigerant under high pressure, proper refrigerant handling techniques should be completed by a qualified technician.



Warning

Live Electrical Components

Personal injury, property damage, or death could result in failure to follow this warning. Follow all electrical precautions when servicing this system, it may be necessary to service or troubleshoot with live electrical circuits. All work should be completed by a qualified technician.

Model Number Identification

Product Catalog Number-Nomenclature

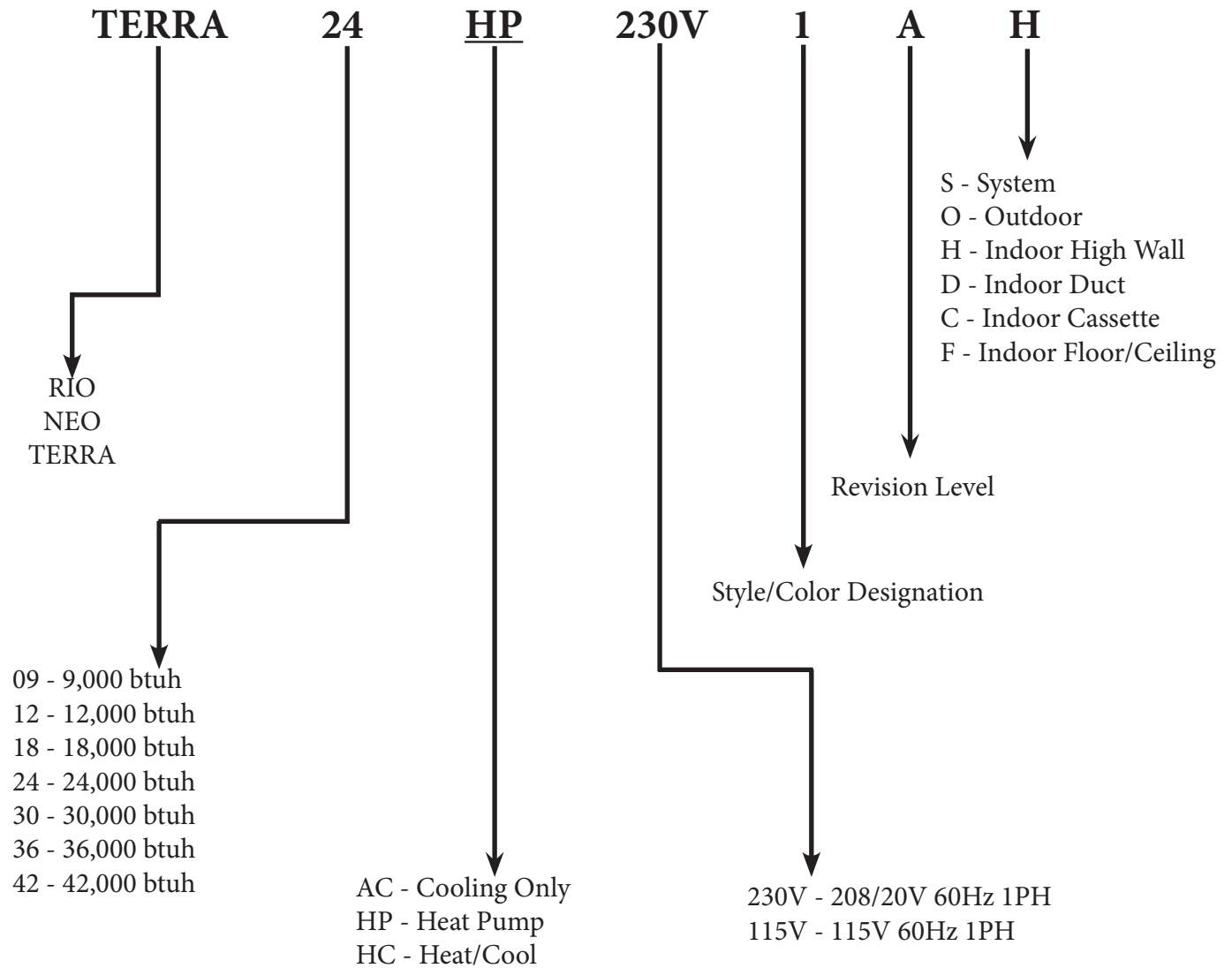

Physical & Electrical Data, cont.

Model		TERRA09HP230V1A	TERRA12HP230V1A
System Type		Heat Pump	
Power Supply		208-230V / 60Hz	208-230V / 60Hz
Rated Current Cooling	Amps	5.7	6.0
Rated Current Heating	Amps	7.0	7.5
System Performance			
Cooling Cap (Min/Max)	Btu/h	9,000 (3,500-9,600)	12,000 (3,100-13,000)
Heating Cap (Min/Max)	Btu/h	9,800 (2,200-11,000)	13,000 (2,400-14,000)
SEER/EER		27 / 14.5	25 / 12.8
HSPF/COP		9.0 / 3.8	9.0 / 3.5
Indoor Unit			
Airflow			
T/H/MH/M/ML/L/mute	CFM	418/300/282/247/218/182/118	453/312/288/259/221/182/118
Sound Pressure Level T/H/MH/M/ML/L/mute	dBa	42/38/36/34/30/26/23	44/38/36/34/30/26/24
Unit Size (WxHxD)	Inches	34.1 x 11.5 x 8.2	34.1 x 11.5 x 8.2
Package Size (WxHxD)	Inches	37.2 x 14.9 x 11.7	37.2 x 14.9 x 11.7
Net/Gross Weight	Lbs	24 / 31	24 / 31
Outdoor Unit			
Compressor Type		DC Inverter-Driven	
Sound Pressure Level	dBa	49	49
Unit Size (WxHxD)	Inches	35.4 x 23.5 x 14.9	35.4 x 23.5 x 14.9
Package Size (WxHxD)	Inches	37.3 x 25.4 x 16.5	37.3 x 25.4 x 16.5
Net/Gross Weight	Lbs	86 / 90	87 / 92
Refrigerant/Charge	Oz.	R410A / 45.9	R410A / 45.9
Installation			
Line Set Size (Liq-Suc)	Inches	1/4" - 1/2"	1/4" - 1/2"
Pre-Charge	Feet	25	25
Max Line Run	Feet	50	66
Max Elevation	Feet	33	33
MCA	Amps	10	10
MOCP	Amps	15	15
Wire Size to Outdoor Unit, # of wires	AWG	14	14
Wire Size / # Wires	AWG	14 / 4	14 / 4

Note: The manufacturer reserves the right to modify the design and/or change the specifications without notice. Please refer to specific installation manual for current information.

Physical & Electrical Data, cont.

Model		TERRA18HP230V1A	TERRA24HP230V1A
System Type		Heat Pump	
Power Supply		208-230V / 60Hz	208-230V / 60Hz
Rated Current Cooling	Amps	7.4	8.5
Rated Current Heating	Amps	7.8	10.3
System Performance			
Cooling Cap (Min/Max)	Btu/h	18,000 (4,600-22,180)	24,000 (6,826-29,352)
Heating Cap (Min/Max)	Btu/h	19,000 (3,400-24,900)	25,000 (7,509-37,543)
SEER/EER		21 / 12.0	21 / 12.0
HSPF/COP		9.8 / 3.5	9.2 / 3.3
Indoor Unit			
Airflow			
T/H/MH/M/ML/L/mute	CFM	588/512/465/418/371/330/282	706/647/589/530/471/412/353
Sound Pressure Level T/H/MH/M/ML/L/mute	dBa	51/48/45/43/39/36/33	52/49/47/45/43/41/38
Unit Size (WxHxD)	Inches	40.1 x 12.6 x 9.1	46.4 x 12.8 x 10.4
Package Size (WxHxD)	Inches	43.2 x 15.6 x 13.4	49.2 x 16.2 x 14.0
Net/Gross Weight	Lbs	31 / 42	40 / 53
Outdoor Unit			
Compressor Type		DC Inverter-Driven	
Sound Pressure Level	dBa	56	56
Unit Size (WxHxD)	Inches	37.6 x 27.6 x 15.6	38.6 x 31.1 x 16.8
Package Size (WxHxD)	Inches	40.5 x 29.5 x 18.0	42.6 x 33.7 x 19.2
Net/Gross Weight	Lbs	110 / 121	153 / 164
Refrigerant/Charge	Oz.	R410A / 56.4	R410A / 77.6
Installation			
Line Set Size (Liq-Suc)	Inches	1/4" - 5/8"	1/4" - 5/8"
Pre-Charge	Feet	25	25
Max Line Run	Feet	82	98
Max Elevation	Feet	33	33
MCA	Amps	15	20
MOCP	Amps	25	30
Wire Size to Outdoor Unit, # of wires	AWG	10	10
Wire Size / # Wires	AWG	14 / 4	14 / 4

Note: The manufacturer reserves the right to modify the design and/or change the specifications without notice. Please refer to specific installation manual for current information.

Product Introduction

System Overview

The Terra Ductless split heat pumps are a single zone unit available in size from 9000 btuh to 24,000 btuh providing heating and cooling. All comfort settings are controlled by a remote control. The Terra unit has many features to enhance comfort and efficiency. The operation of these features will be explained later in this service manual.

Superior inverter technology is used to control capacity while maintaining maximum efficiency. The Terra systems are equipped with G10 inverter technology providing precise control over the compressor frequency based on operating pressures and temperatures. Should an abnormal condition occur, the software will adjust the compressor frequency or shut down the system indicating the appropriate fault.

The indoor unit contains a digital display, which will indicate the current fault. The evaporator, swing motors, fan motors and circuit board are also components of the indoor unit. The indoor units have a bypass switch to bypass the remote control if lost or batteries fail. This will be explained later in this service manual.

The systems require R410A and are pre-charged for 25' of lineset. Please refer to your installation manual for additional charge for linesets longer than 25'.

The systems use a PVE oil and should require no additional oil. All Terra units utilize an Oil Return Mode which will return oil to the compressor should the need arise.

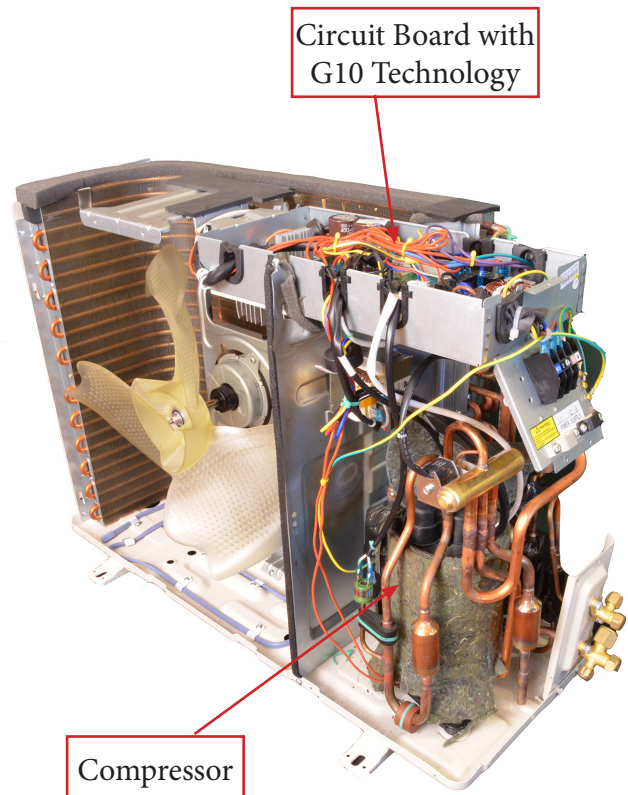
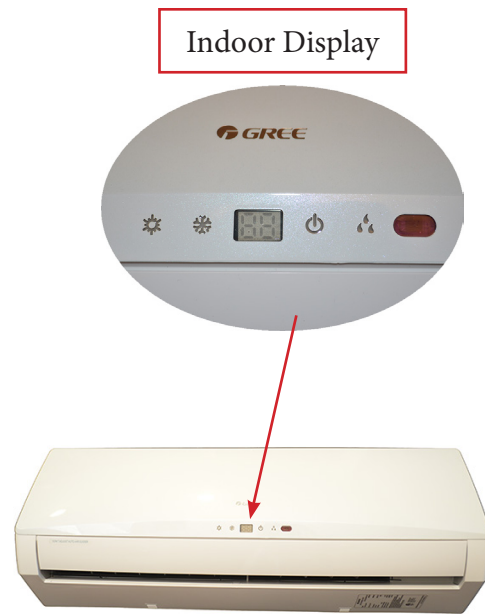

Product Introduction

Refrigeration Components

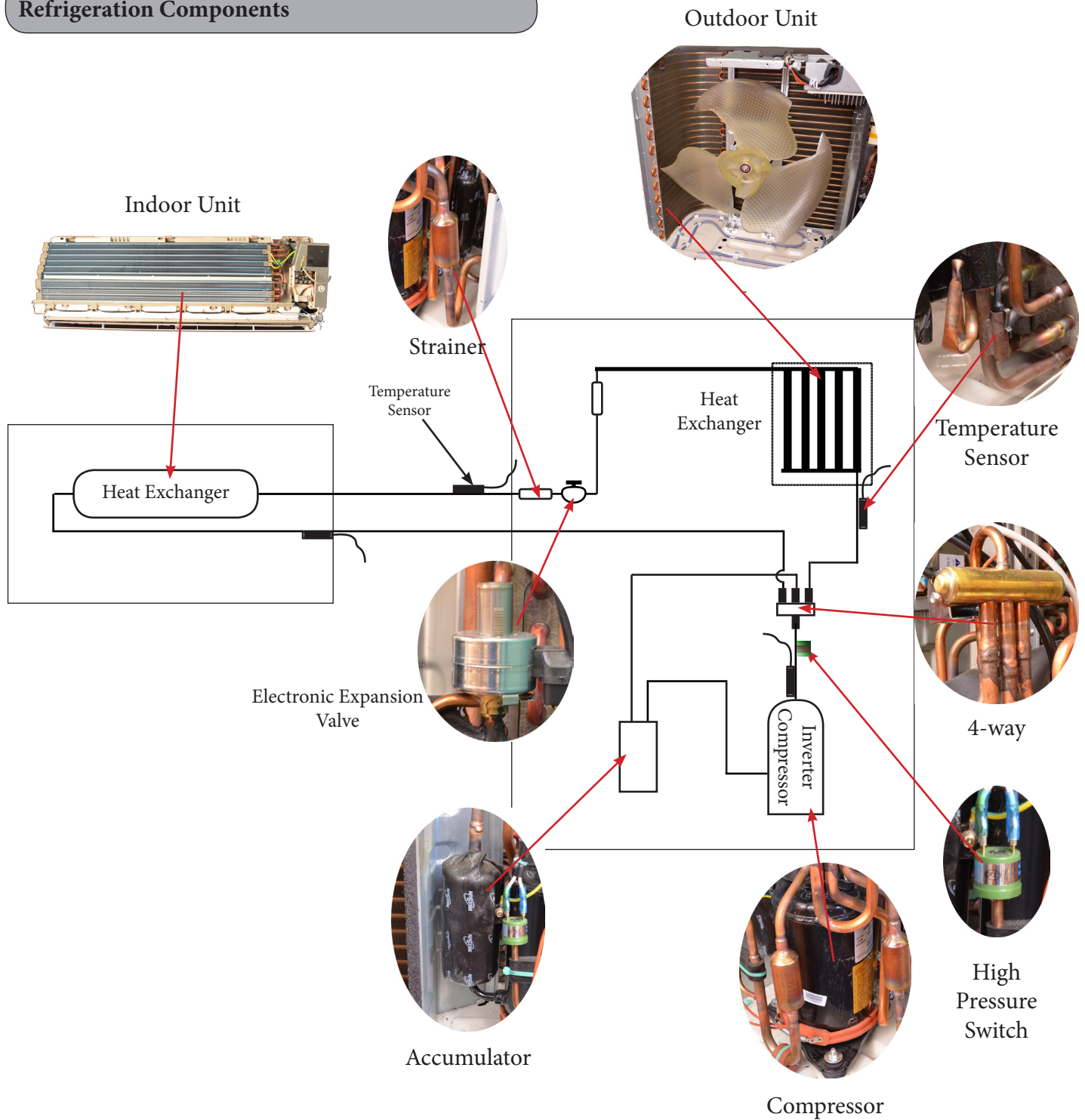

Note;
Component locations may vary depending on models.

Product Introduction

Cooling Mode

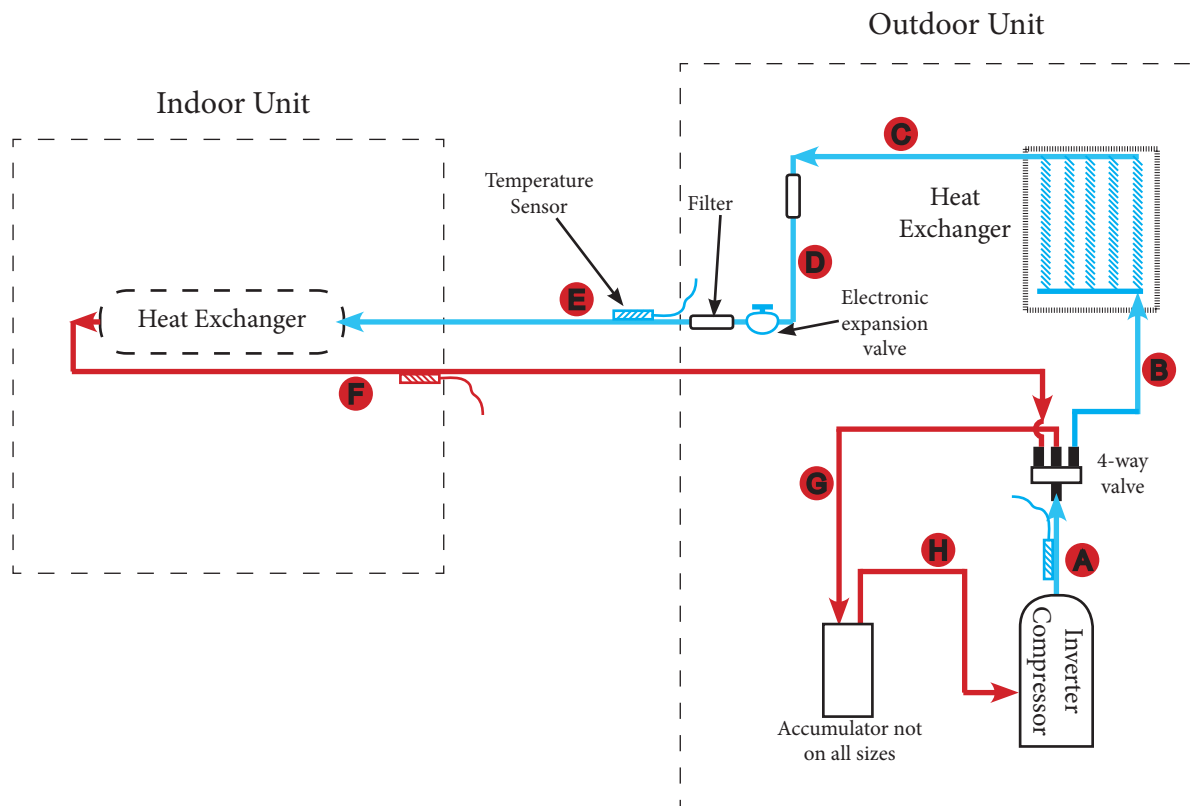

- A. Hot gas is discharged from the compressor. The temperature of the gas is monitored by the Discharge Temperature sensor and sent to the outdoor control panel.
- B. The hot gas is directed through the 4-way valve, then enters the outdoor coil. The hot gas will be slightly subcooled, however there are no pressure ports to take measurements.
- C. The subcooled liquid will enter the filter to remove contaminants.
- D. The subcooled liquid will enter the Electronic Expansion Valve (EEV) and will be regulated to about a 10 degree F superheat level. The EEV will adjust its flow based upon the temperature sensor readings. The adjustment process and compressor speed are controlled by the outdoor circuit board.
- E. The refrigerant leaving the EEV will be in a low pressure/temperature saturated state. This cold saturated refrigerant will move through the coil absorbing heat. This liquid will flash to a vapor and will be superheated to about 10 degrees F. Since this tubing is cold, it must be insulated.
- F. The superheated vapor is returned to the outdoor unit's 4-way valve.
- G. The refrigerant will flow to the accumulator (not all models will have an accumulator) where liquid and vapor are separated.
- H. The refrigerant will flow to the compressor and complete another refrigeration cycle.

The control board will monitor the temperature and pressures and adjust the frequency of the compressor and flow rate of the EEV as needed. There are no pressure charts to evaluate temperature or pressures.

Product Introduction

Heating Mode

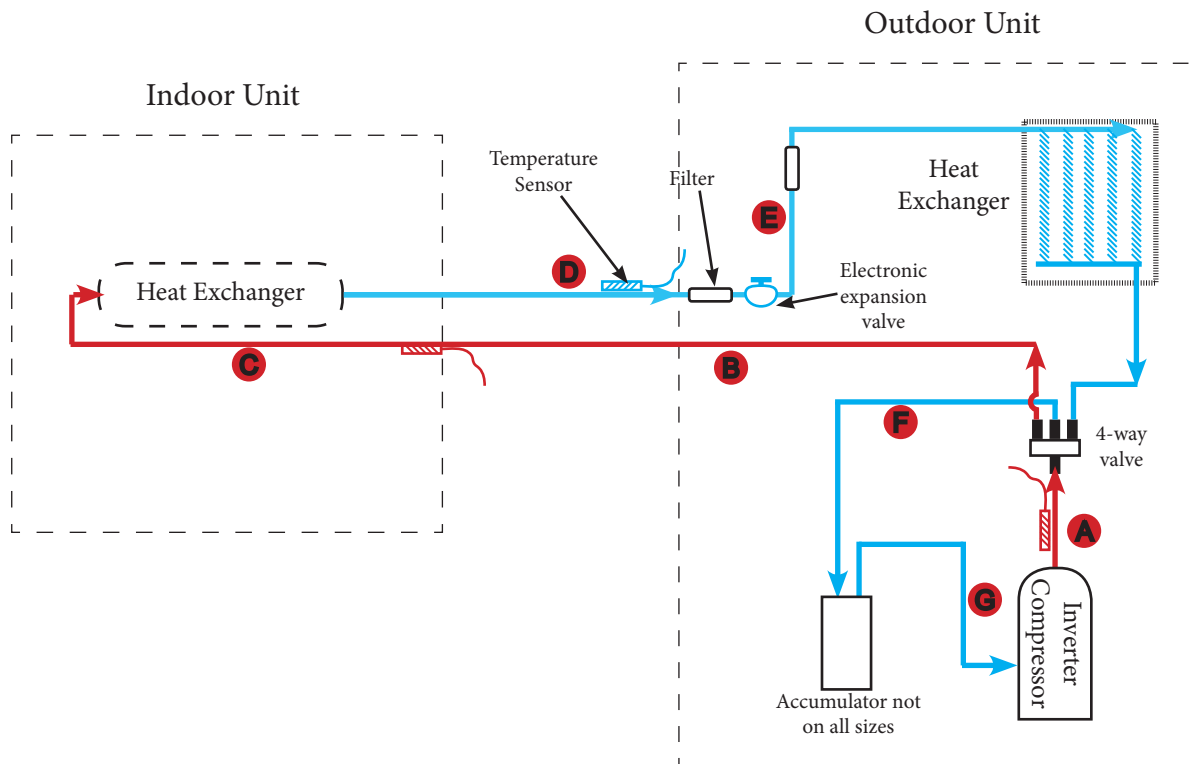

- A. Hot gas is discharged from the compressor. The temperature of the gas is monitored by the Discharge Temperature sensor and sent to the outdoor control panel.
- B. The hot gas is directed through the 4-way valve to the indoor coil making the line a hot gas line.
- C. The hot gas will enter the indoor coil and condense to a saturated mix as it travel through the coil and will be slightly subcooled.
- D. The refrigerant returns to the outdoor unit through the filter, then through the EEV reducing the refrigerant to a low pressure liquid and will maintain 10 degrees F of superheat.
- E. The cold refrigerant will travel through the outdoor coil (evaporator) and will pick up heat from the outdoor air. This will cause the cold saturated refrigerant to flash to a saturated mixture which will be superheated to 10 degrees F.
- F. The superheated vapor will travel through the 4-way valve to the accumulator which will prevent liquid floodback.
- G. The superheated gas will enter the compressor for another refrigeration cycle.

The control board will monitor the temperature and pressures and adjust the frequency of the compressor and flow rate of the EEV as needed. There are no pressure charts to evaluate temperature or pressures.

Product Introduction

Indoor Unit Components

Terra 9,000 btuh Indoor Unit
Other Terra models may vary slightly.

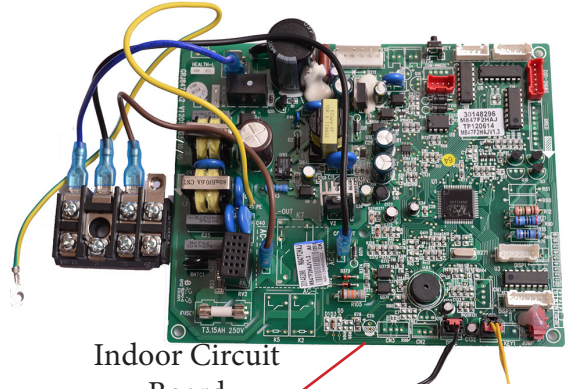

Indoor Circuit Board

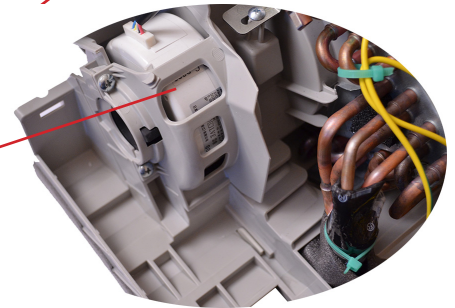
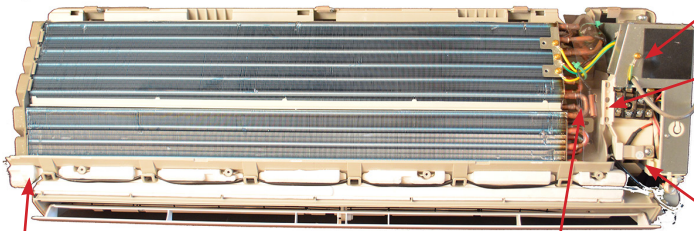

Fan Motor

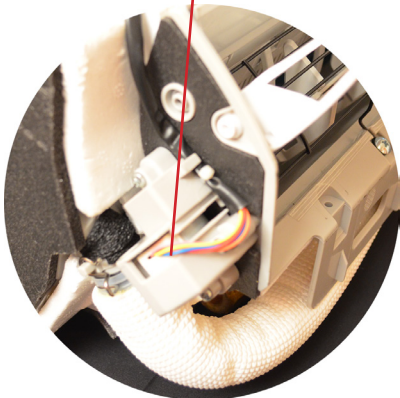

Horizontal Swing Motor

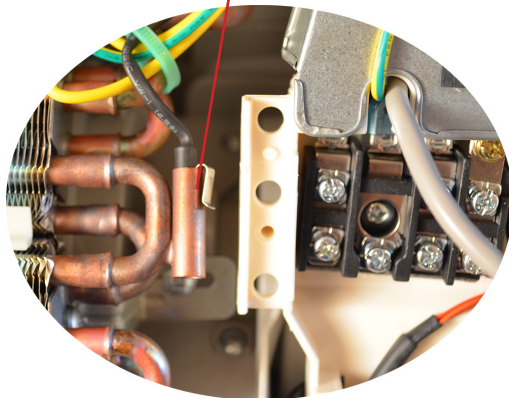

Indoor Tube Thermistor

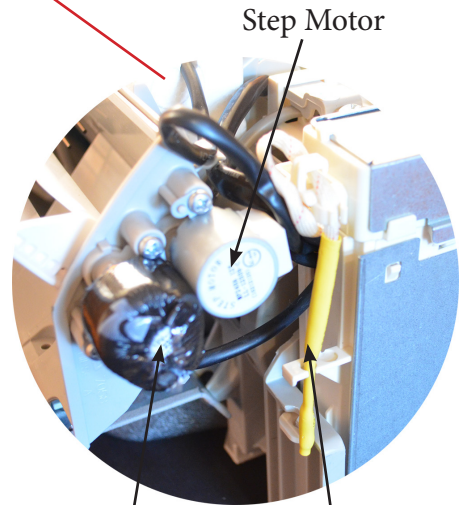

Vertical Swing Motor

Ambient Temperature Sensor

Step Motor

Product Introduction

Outdoor Unit Components

Terra 9,000 btuh Outdoor Unit
Other Terra models may vary slightly.

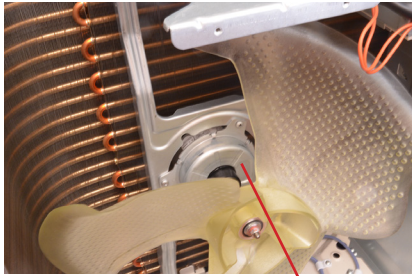

Outdoor Fan



Circuit Board

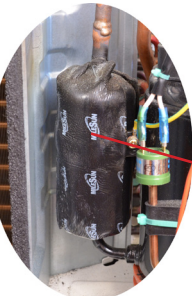
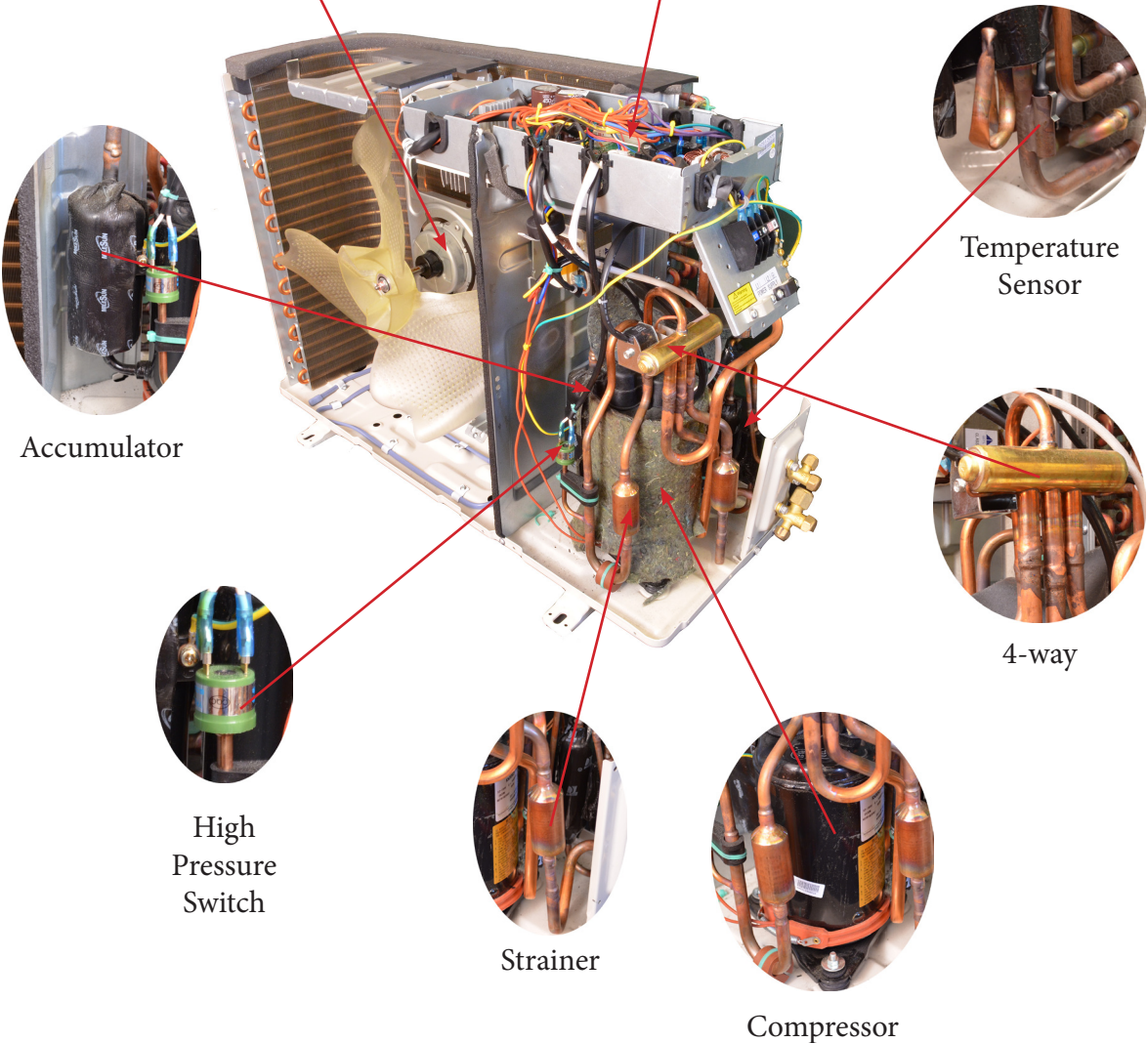

Accumulator



Temperature Sensor

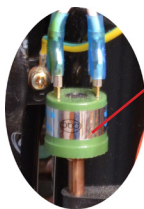

High Pressure Switch

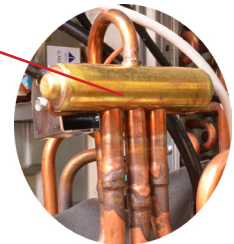

4-way



Strainer



Compressor

Note;
Component locations may vary depending on models.

Product Introduction

Operation Characteristic Curve

09K

Cooling

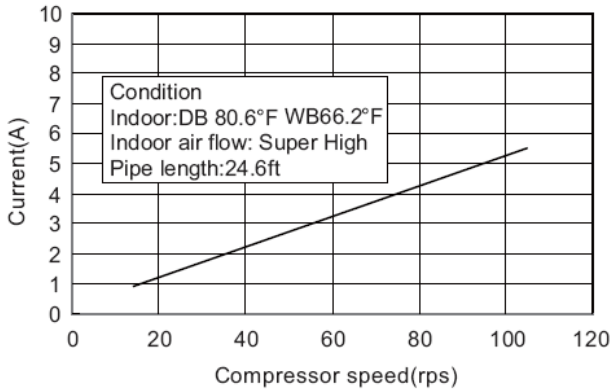

Heating

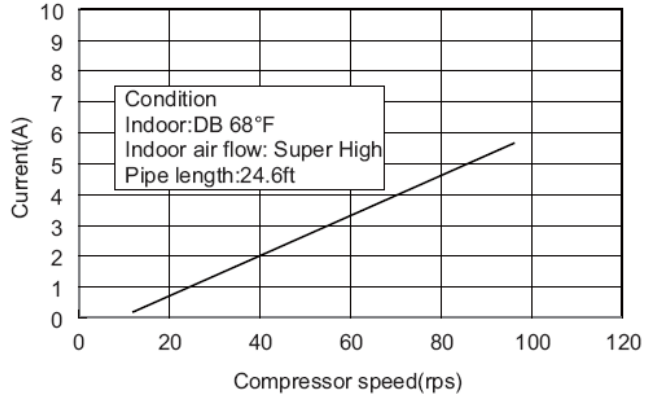

12K

Cooling

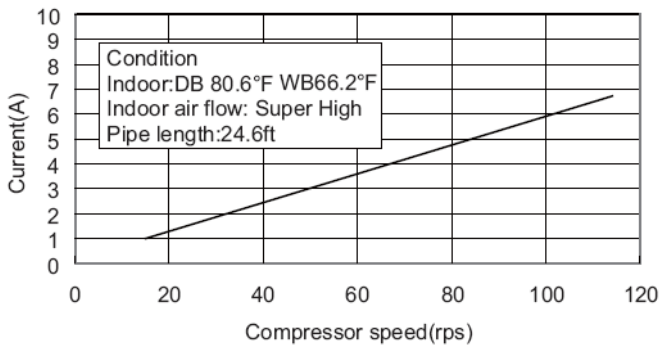

Heating

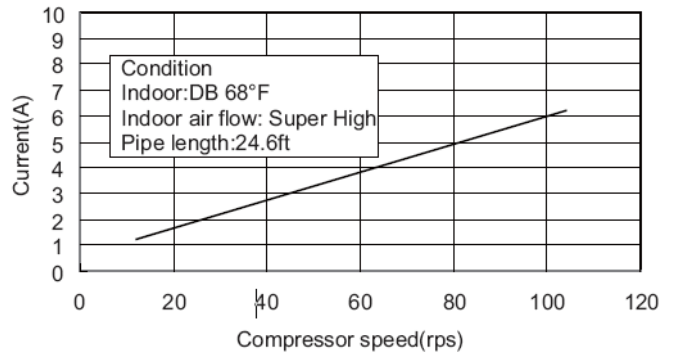

18/24K

Cooling

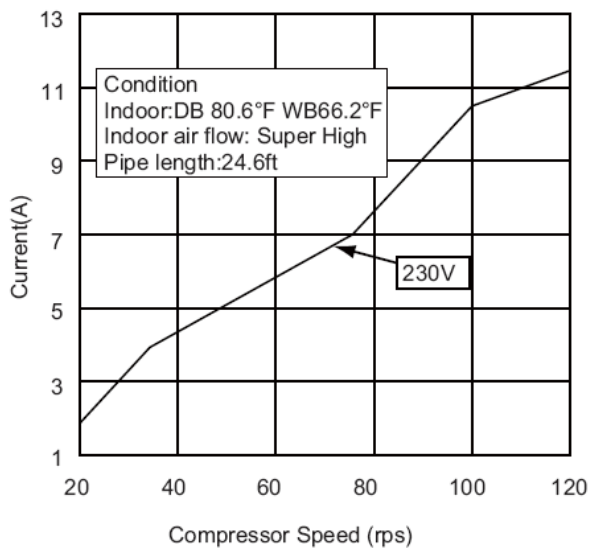

Heating

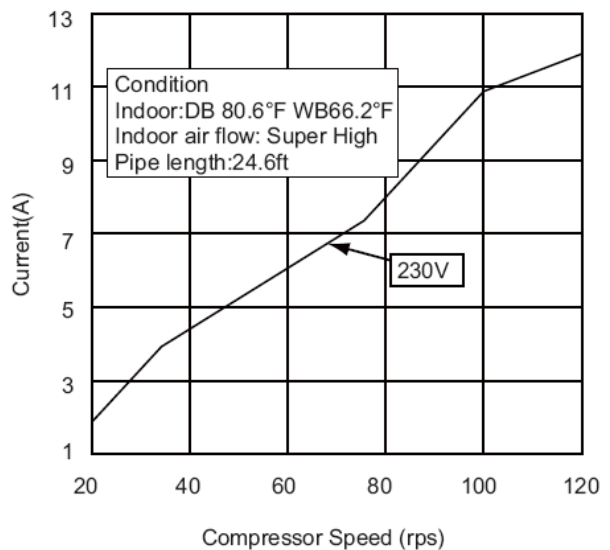

Product Introduction

Capacity Variation Ratio According to Temperature

09/12K

Cooling

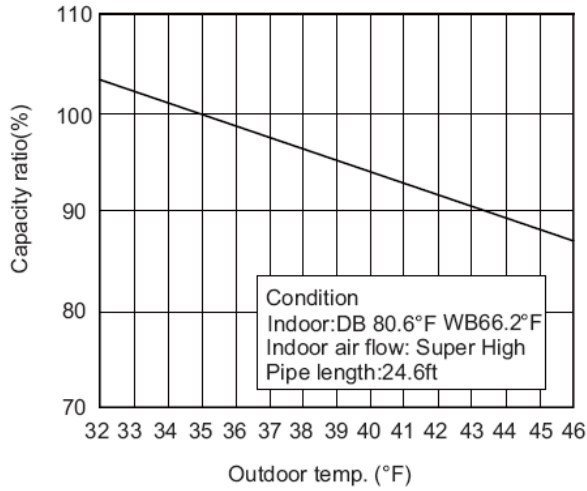

Heating

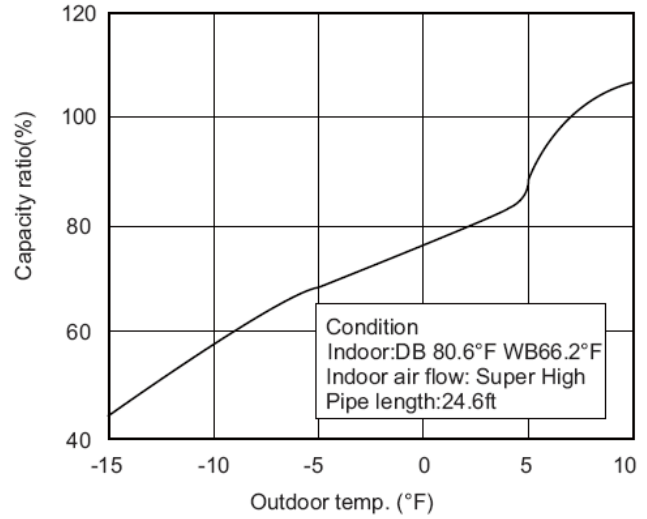

18/24K

Cooling

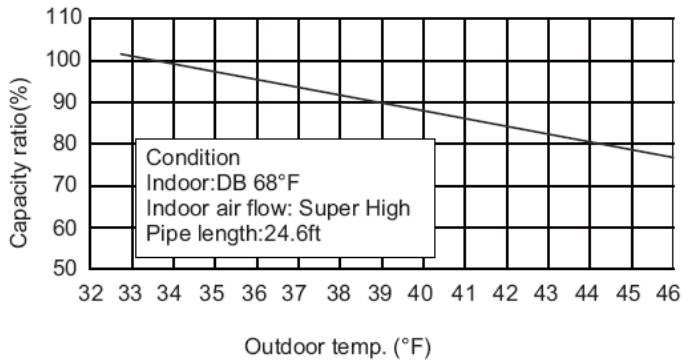

Heating

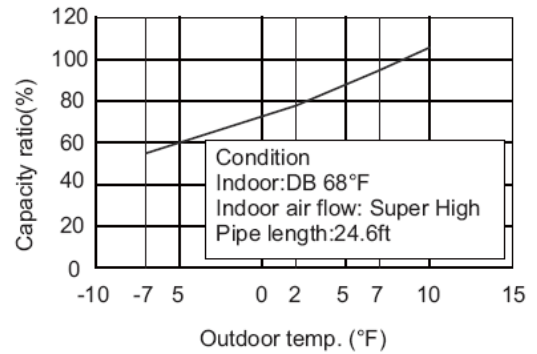

Product Introduction

Operation Data

Cooling

Temperature Condition (°F)		Model	Pressure (PSI)	Heat Exchanger Pipe Temperature		Indoor Fan Mode	Outdoor Fan Mode	Compressor Speed (rps)
Indoor	Outdoor			T1 (°F)	T2 (°F)			
80.6/66.6	95/75.2	9K	135	57.2	98.6	Turbo	High	46
		12K	152	59	98.6	Turbo	High	70
		18/24K	131-160	46.4-51.8 to 51.6-57.2	167-181.4 to 98.6-118.4	Turbo	High	75

Heating

Temperature Condition (°F)		Model	Pressure (PSI)	Heat Exchanger Pipe Temperature		Indoor Fan Mode	Outdoor Fan Mode	Compressor Speed (rps)
Indoor	Outdoor			T1 (°F)	T2 (°F)			
70/60	47/43	9K	401	113	41	Turbo	High	56
		12K	308	107.6	41	Turbo	High	73
68/59	44.6/42.8	18/24K	319-348	167-181.4 to 98.6-113	33.8-37.4 to 35.6-42.8	Turbo	High	75

Notes:

- (1) Measure surface temperature of heat exchanger pipe around center of heat exchanger path U-Bend.
- (2) Length of connecting tubing = 24.6 ft.
- (3) P = Pressure PSI
 T1 = Inlet and Outlet Temperature for Evaporator
 T2 = Inlet and Outlet Temperature for Condenser

Product Introduction

Noise Criteria Curve Tables

09K

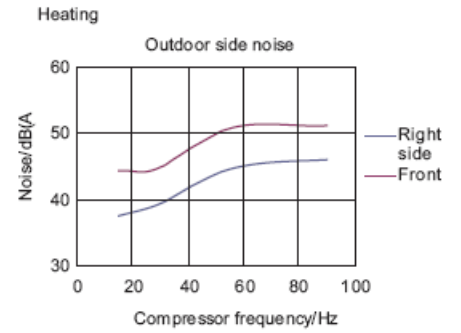
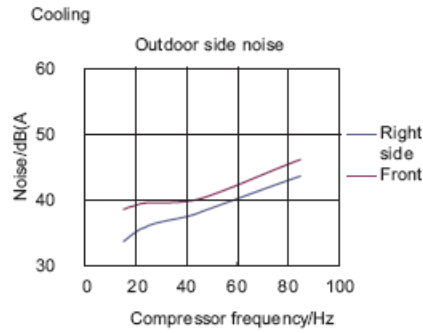
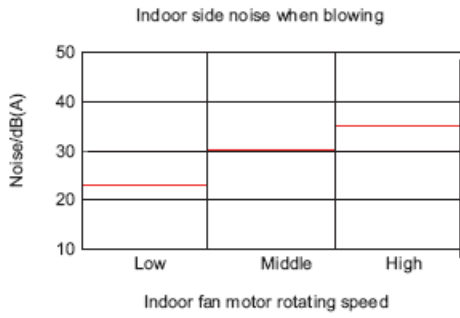

12K

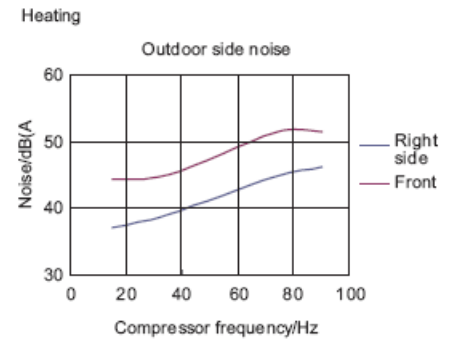
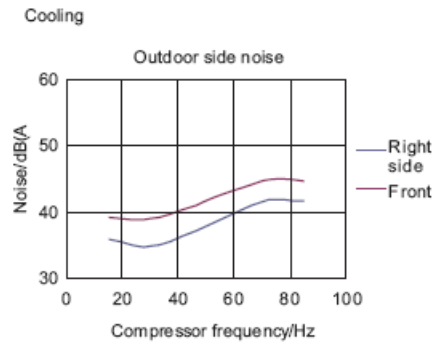
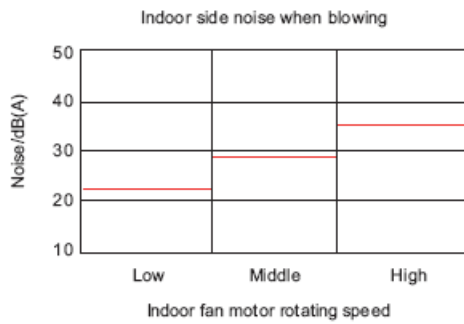

18/24K

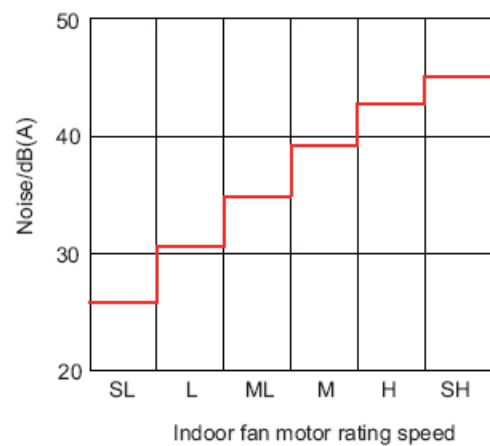
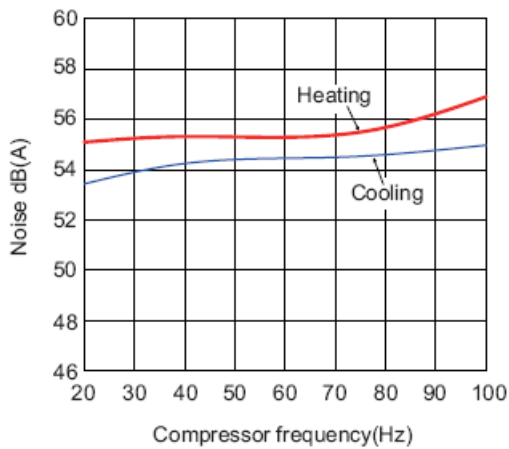

Product Introduction

System Operation 9,000/12,000 btuh Models

Basic Functions

The compressor should stay off for at least 3 minutes before starting the unit. The compressor circuit has a 3 minute delay if the compressor is de-energized during a run cycle. If the compressor starts from a de-energized cycle, there will be no time delay. The compressor has a minimum runtime of 6 minutes regardless of room temperature.

1) Cooling Mode

Cooling Process

When the indoor ambient rises 2° F above the preset temperature, the unit will start the cooling cycle. The outdoor fan and compressor will start. The indoor fan will run continuously at the selected speed. The outdoor unit will monitor the appropriate temperatures and pressure and adjust the compressor speed and the EEV as required. If the indoor ambient is $> 2^{\circ}$ F then the preset temperature, the compressor will increase the frequency; $< 2^{\circ}$ F the compressor will begin reducing the frequency. The G10 technology will control compressor speed based on indoor load and compressor amperage. When the indoor temperature is satisfied, the compressor will stop, then 30 seconds later the outdoor fan will stop.

Evaporator Freeze Protection

The software will monitor the indoor evaporator coil form freezing.

The following will occur 6 minutes after the compressor has been operating in the cooling or dry mode:

If the evaporator temperature drops below 36° F, the compressor will operate at a reduced frequency. If the evaporator is below 30° F for 3 minutes, the compressor will stop, 30 seconds later the outdoor fan will stop. In cooling mode, the indoor fan and swing motor will remain on. If the evaporator temperature is $\geq 50^{\circ}$ F and the compressor is off for at least 3 minutes, the compressor will resume its normal operation state.

Overcurrent Protection

The software will monitor the compressor current to maintain it in a safety and reliable operating range.

If the total current ≤ 6 amps, the compressor speed frequency is allowed to increase. If the current ≥ 7 amps, the compressor speed frequency will not increase. If the total current ≥ 8 amps, the unit will operate and decrease the compressor speed. If the current ≥ 9 amps, the compressor will stop and the indoor fan will stop after 30 seconds.

2) Dry Mode

Drying Process

This feature will not take the place of a dehumidifier, it is intended to dry the filter and slightly cool the air. If the indoor ambient temperature is greater than the preset temperature, the unit will enter the cooling and drying mode, in which case the compressor will operate and the indoor fan will run at a low speed. When the indoor ambient temperature is at or below the preset temperature, the unit will operate in it previous running state. When the indoor ambient drops to more than 2° F below the preset temperature the compressor will stop running, then 30 seconds later the outdoor fan will stop, the indoor fan will run at low speed.

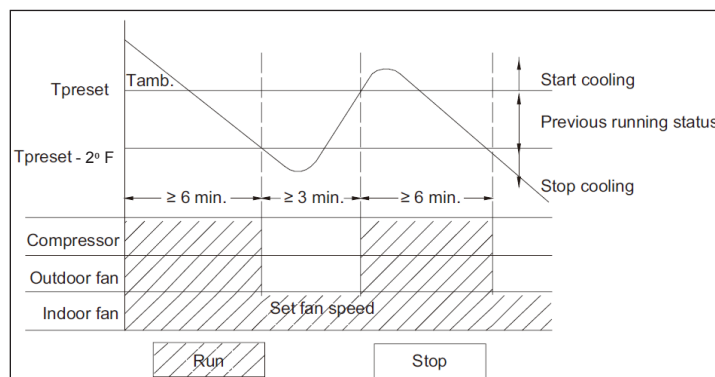

Product Introduction

System Operation 9,000/12,000 btuh Models, cont.

Basic Functions

3) Heating Mode

Heating Process

When the indoor ambient drops 2° F below the preset temperature, the unit will start the heating cycle. The outdoor fan, compressor and 4-way valve will operate. The indoor fan will operate in the “Cold Air Prevention” mode in which the indoor fan will have a 2 minute delay after the call for heating. The indoor evaporator coil temperature must reach 104° F before the indoor fan will start, this will prevent cold air from discharging from the indoor coil. When the indoor evaporator coil temperature is $> 104^{\circ}$ F, the indoor fan will operate at low speed for 1 minute. With 1 minute of operation or 2 minutes of no fan operation and the indoor evaporator coil temperature is $> 108^{\circ}$ F, the indoor fan will operate at its preset condition.

If the indoor ambient temperature is $< 9^{\circ}$ F and $> 2^{\circ}$ F of the preset temperature, the unit will run in its original mode of operation.

If the compressor is running and the mode is changed from cooling to heating, the 4-way valve will be energized 2-3 minutes later.

If the indoor ambient temperature is $\geq 9^{\circ}$ F than the preset temperature, the compressor will stop and the outdoor fan will stop after a 30 second delay. The indoor fan will continue to operate at its preset mode. The G10 technology will determine compressor frequency based on ambient temperatures.

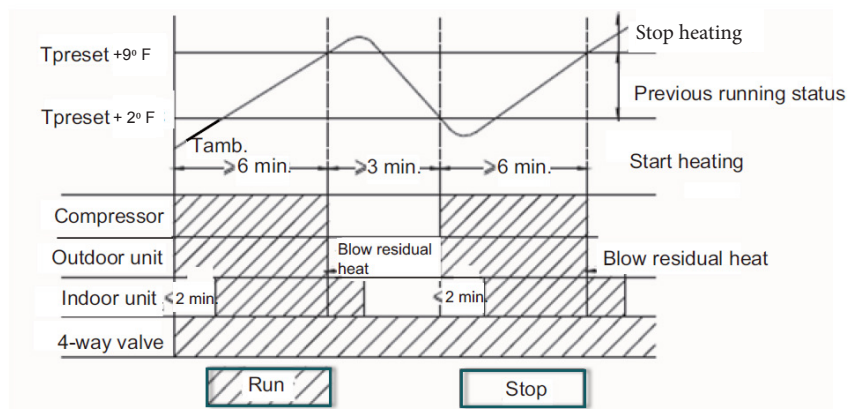

Product Introduction

System Operation 9,000/12,000 btuh Models, cont.

Basic Functions

Defrost Process

1) The unit will enter defrost when the following conditions are met:

- A. Outdoor ambient $\leq 41^{\circ}$ F
- B. Compressor had accumulated more than 3 hours of operation in heating mode
- C. The outdoor coil $\leq 32^{\circ}$ F

Note: The compressor runtime will be cleared when the outdoor ambient is $> 41^{\circ}$ F or when the compressor has started up after changing to cooling or drying mode and defrost has finished. The runtime will not be cleared when the unit has stopped after reaching the setpoint temperature, a protection fault or changing to fan mode.

There are 3 perimeters used in the defrost algorithms, Outdoor ambient ($T_{\text{outdoor ambient}}$), Outdoor tube ($T_{\text{outdoor tube}}$) and a calculated $T_{\text{compensation}}$

$T_{\text{compensation}}$ is calculated by the following:

- D. After power-up, for the first defrost $T_{\text{compensation}} = 32^{\circ}$ F
- E. $T_{\text{outdoor tube}} > 36^{\circ}$ F then $T_{\text{compensation}} = 32^{\circ}$ F
- F. $T_{\text{outdoor tube}} \leq 36^{\circ}$ F then $T_{\text{compensation}} = 37^{\circ}$ F

2) When heating has operated continuously for 45 minutes, or accumulated for 90 minutes, the unit will enter defrost mode in 3 minutes after meeting any of the conditions below:

- A. Outdoor ambient $\geq 41^{\circ}$ F and outdoor coil $\leq 28^{\circ}$ F
- B. 28° F $\leq T_{\text{outdoor ambient}} < 41^{\circ}$ F, $T_{\text{outdoor tube}} \leq 21^{\circ}$ F
- C. 23° F $\leq T_{\text{outdoor ambient}} < 28^{\circ}$ F $\leq T_{\text{outdoor tube}} \leq 18^{\circ}$ F
- D. 14° F $\leq T_{\text{outdoor ambient}} < 23^{\circ}$ F, $T_{\text{outdoor tube}} - T_{\text{compensation}} \leq (T_{\text{outdoor ambient}} - 37^{\circ}$ F)

3) During defrost, if run time for the compressor does not reach 3 minutes, the defrost cycle will not start for the next 2 hours. At that time the compressor stops operation and 30 seconds later the outdoor fan will stop. 30 seconds after this the 4-way reversing valve will de-energized. Following another 30 second delay, the compressor will increase its compressor speed for defrosting. Defrosting will last for 450 seconds or until the $T_{\text{outdoor tube}} \geq 50^{\circ}$ F, at this temperature the compressor will decrease its compressor speed for 30 seconds, then will stop. In another 30 seconds the 4-way valve will energize, the 60 seconds later the compressor and outdoor fan will start. The compressor speed for defrosting will be 85hz. During Defrost mode, a "H1" will be displayed on the indoor front panel display indicating the user selected mode has been overridden and the system is performing a outdoor coil defrost operation.

Product Introduction

System Operation 9,000/12,000 btuh Models, cont.

Basic Functions

System Protection

Cold Air Prevention (Heating mode with compressor running)

The system guards against discharging cold air in heating mode. It will delay the indoor fan until the evaporator coil has warmed up to discharge warm, comfortable air into the room.

1) When the $T_{\text{indoor,ambient}} < 75^{\circ}\text{F}$ and the $T_{\text{indoor,tube}} \leq 104^{\circ}\text{F}$ with the fan in a stopped state, the indoor fan will begin to run at low speed after a 2 minute delay. This will reduce cold air upon heating startup. Within 2 minutes, if $T_{\text{indoor,tube}} > 104^{\circ}\text{F}$, the indoor fan will run at low speed. After 1 minute of operation, the fan will run at the preset fan mode. Within 1 minute of low speed operation or 2 minutes of no fan operation, with the $T_{\text{indoor,tube}} > 108^{\circ}\text{F}$, the fan will run at the preset mode.

2) If the $T_{\text{indoor,ambient}} \geq 75^{\circ}\text{F}$ and the $T_{\text{indoor,tube}} \leq 108^{\circ}\text{F}$ the indoor fan will run at low speed for 1 minute than run at the preset mode. After 1 minute of low speed operation, if the and the $T_{\text{indoor,tube}} > 108^{\circ}\text{F}$ the fan will operate at its preset mode.

Note:

The $T_{\text{indoor,ambient}}$ in 1 & 2 above refers to the unit going into the heating mode coming out of defrost.

Overcurrent and Speed Protection (Total Current = I_{total})

The software will monitor the compressor current draw and adjust the compressor speed in order to maintain the inverter and compressor in a safety and reliable operating range.

- A. If $I_{\text{total}} \leq 6$, an increase in frequency will be allowed
- B. If $I_{\text{total}} \geq 7$, increasing the frequency is not allowed.
- C. If $I_{\text{total}} \geq 8$, the compressor will decrease its frequency
- D. If $I_{\text{total}} \geq 9$, the compressor will stop and the indoor fan will stop after 30 seconds.

4) Fan Mode

Under this mode, the fan will run at the preset speed and the outdoor fan, compressor and 4-way valve will stop.

5) Auto Mode

Auto Mode Process

Setting the auto mode will run the unit in heat or cool automatically depending on $T_{\text{indoor,ambient}}$

1) Operating Parameters

- A. If the $T_{\text{indoor,ambient}} \geq 79^{\circ}\text{F}$ the unit will operate in cooling mode. The set temperature is 77°F .
- B. If the $T_{\text{indoor,ambient}} \leq 72^{\circ}\text{F}$ the unit will operate in heat mode. The set temperature is 68°F .
- C. When the $T_{\text{indoor,ambient}} \leq 73^{\circ}\text{F}$ and $\geq 77^{\circ}\text{F}$, the unit will operate in the previous state. If it is energized for the first time, it will run in Fan mode
- D. In auto mode, the cooling frequency will be the same as the cooling only mode and the heating frequency will be the same as the heating only mode.

2) Protection

- A. In cooling operation, protection is the same as the cooling only mode
- B. In heating operation, protection is the same as the heating only mode
- C. When the indoor ambient temperature changes, the operation mode will be automatically selected. Once started the compressor will have a 6 minute runtime.

Product Introduction

System Operation 9,000/12,000 btuh Models, cont.

Basic Functions

6) Common Protection Functions and Fault Displays

Coil High Temperature Protection

T_{tube} = measured temperature of outdoor coil in cooling mode, measured temperature of indoor coil in heating mode.

1) Outdoor Coil High Temperature Protection - *In cooling mode the software will monitor the outdoor coil for an abnormal high temperature condition.*

- A. If $T_{\text{tube}} \leq 126^{\circ}\text{F}$, the unit will return to its original operation state
- B. If $T_{\text{tube}} \geq 131^{\circ}\text{F}$, frequency rise is not allowed
- C. If $T_{\text{tube}} \geq 136^{\circ}\text{F}$, the compressor will run at reduced frequency
- D. If $T_{\text{tube}} \geq 144^{\circ}\text{F}$, the compressor will stop and the indoor fan will operate at preset speed

2) Indoor Coil Temperature Protection - *In heating mode the software will monitor the indoor coil for an abnormal high temperature condition.*

- A. If $T_{\text{tube}} \leq 122^{\circ}\text{F}$, the unit will return to its original operation state
- B. If $T_{\text{tube}} \geq 127^{\circ}\text{F}$, frequency rise is not allowed
- C. If $T_{\text{tube}} \geq 133^{\circ}\text{F}$, the compressor will run at reduced frequency
- D. If $T_{\text{tube}} \geq 140^{\circ}\text{F}$, the compressor will stop and the indoor fan will blow residual heat and then stop

3) Compressor Discharge Temperature Protection

The software will monitor the compressor discharge for an abnormal high temperature condition.

- A. If $T_{\text{tube}} \geq 208^{\circ}\text{F}$, frequency rise is not allowed
- B. If $T_{\text{tube}} \geq 217^{\circ}\text{F}$, the compressor will run at reduced frequency
- C. If $T_{\text{tube}} \geq 230^{\circ}\text{F}$, the compressor will stop
- D. If $T_{\text{tube}} \leq 194^{\circ}\text{F}$ and the compressor has been off for at least 3 minutes, the compressor will resume operation

Communication Fault

If the unit fails to receive correct signals for a 3 minutes, communication fault will occur and the whole system will stop and a "E6" will be displayed on the front panel of the indoor unit.

Module Protection

Under module protection mode, the compressor will stop. When the compressor remains off for 3 minutes, the compressor will resume operation. If the module protection occurs six time in succession, the compressor will remain off. This is a thermal protection for the indoor module (AP1).

Compressor Protection

The compressor contains a thermal overload switch to protect it from abnormal conditions.

If temperature sensed by the overload sensor is over 239°F , the compressor will stop and the outdoor fan will stop after 30 seconds. When the temperature is below 203°F , the overload protection will reset to normal state.

DC Buss Voltage Protection

The software will monitor the DC bus voltage.

If voltage on the DC Bus is below 150 or over 420v, the compressor will stop and the outdoor fan will stop in 30 seconds. When the voltage on the DC bus returns to normal and the compressor has been off for 3 minutes, the compressor will resume its operation.

Product Introduction

System Operation 9,000/12,000 btuh Models, cont.

Other Controls

1) On/Off

The on-off state will change with each button press.

2) Mode Selection

Press the "Mode" button to change from Auto, Cool, Dry, Fan or Heat Pump

3) Temperature Setting

Each time you press the "TEMP+" or "TEMP-" button the temperature setting will change by 1° F. The temperature range is 60.8° F - 86° F. In Auto Mode this button will not function.

4) Time Switch

The unit will stop and start by setting the Timer on the remote controller.

5) Energy Savings Mode (Press Temp & Clock simultaneously, display will indicate "SE")

In heating mode, refer to the Cold Air Prevention explained in the (3) Heating Mode process .

In cooling mode, the fan speed will adjust according to the fan speed curve below:

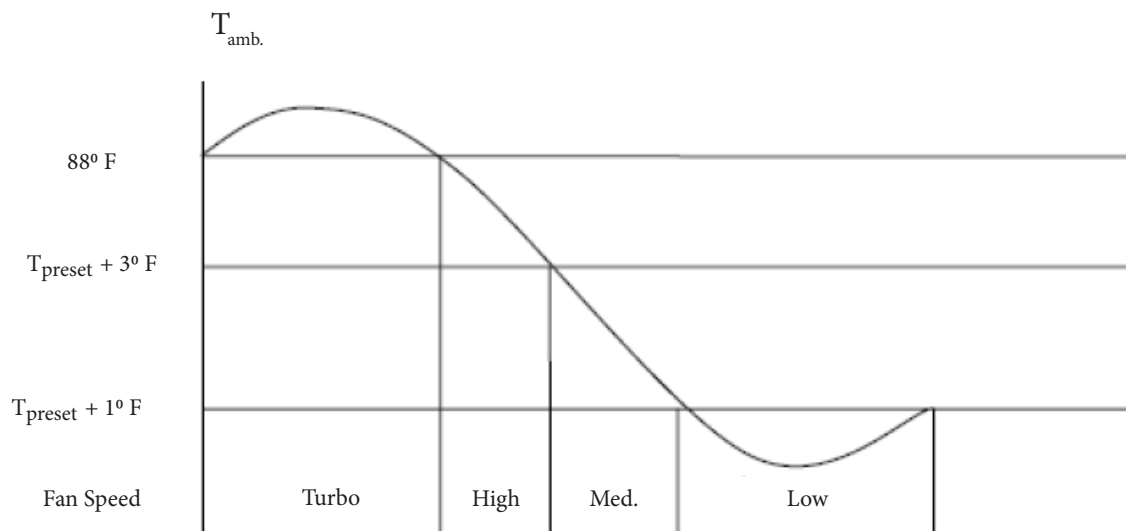

Product Introduction

System Operation 9,000/12,000 btuh Models, cont.

Other Controls

6) Sleep Control

The Terra has 3 Sleep mode settings to improve comfort and energy savings.
Auto Mode and Fan Mode do not utilize the Sleep Mode Settings

Sleep Mode 1 (Gradual Cycle)

1. Cool or Dry Mode
 - a) After 1 hour of operation the temperature setting will raise 2° F
 - b) After 2 hours of operation the temperature setting will increase 4° F and stay at this setting until the sleep mode is canceled
2. Heat Mode
 - a) After 1 hour of operation the temperature setting will decrease 2° F
 - b) After 2 hours of operation the temperature setting will decrease 4° F and stay at this setting until the sleep mode is canceled

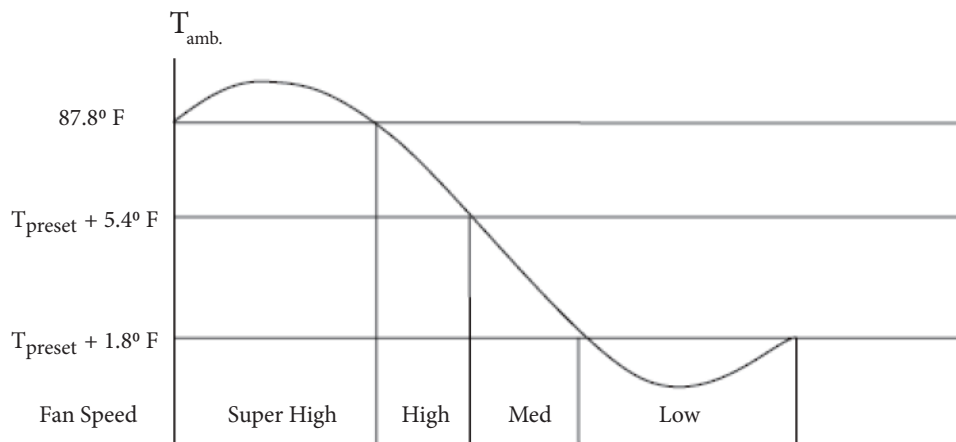

Product Introduction

System Operation 9,000/12,000 btuh Models, cont.

Other Controls

Sleep Mode 2 (Adaptive Cycle)

1. Cool or Dry Mode (Initial setpoint between 61° F. - 74° F.)
 - a) After 1 hour of operation the temperature setting will raise 2° F every hour
 - b) After 3 hours of operation the temperature setting will raise 6° F above initial setpoint and stay at this setting
 - c) After 7 hours of operation, the setpoint will move to 4° F. above the initial setpoint and remain until the sleep mode is canceled.
- Cool or Dry Mode (Initial setpoint between 75° F. - 81° F.)
 - a) After 1 hour of operation the temperature setting will raise 2° F every hour
 - b) After 3 hours of operation the temperature setting will raise 4° F above initial setpoint and stay at this setting
 - c) After 7 hours of operation, the setpoint will move to 2° F. above the initial setpoint and remain until the sleep mode is canceled.
- Cool or Dry Mode (Initial setpoint between 82° F. - 85° F.)
 - a) After 1 hour of operation the temperature setting will raise 2° F every hour
 - b) After 3 hours of operation the temperature setting will raise 24° F above initial setpoint and stay at this setting
 - c) After 7 hours of operation, the setpoint will move back to the initial setpoint and remain until the sleep mode is canceled.
- Cool or Dry Mode (Initial setpoint above 85° F.)
 - a) The original setpoint will be maintained for 7 hours, then after 7 hours it will decrease by 1° F until the sleep mode is canceled
2. Heat Mode (Initial setpoint 61° F.)
 - a) The unit will maintain this setpoint until Sleep Mode is canceled
- Heat Mode (Initial setpoint between 62° F. - 68° F.)
 - a) After 1 hour of operation the temperature setting will decrease 2° F and maintain this setpoint until Sleep Mode is canceled
- Heat Mode (Initial setpoint between 69° F. - 81° F.)
 - a) After 1 hour of operation the temperature setting will decrease 2° F and maintain this setpoint until Sleep Mode is canceled
- Heat Mode (Initial setpoint between 82° F. - 86° F.)
 - a) After 1 hour of operation the temperature setting will decrease 2° F every hour
 - b) After 3 hours, the setpoint will be fixed at 6° F below the initial setpoint and remain at this setpoint until Sleep Mode is canceled

Product Introduction

System Operation 9,000/12,000 btuh Models, cont.

Other Controls

Sleep Mode 3 (Customized Cycle)

You will be required to enter 8 room setpoint values for 8 hours of runtime. The last room setpoint value will be maintained until Sleep Mode is canceled.

In Sleep Mode 3, press the “Turbo” button to enter setup mode. The remote controller will display “1:00” in the time location. Use the “+” and “-” buttons to select the desired room setpoint for the 1st hour of runtime, then press the “Turbo” button to save the data.

The remote controller will display “2:00”. Once again, use the “+” and “-” buttons to select the desired room setpoint for the second hour of run time. Press the “Turbo” button to save the data.

Repeat this procedure for the remaining hours (total of 8). After all 8 settings have been saved, the remote controller will automatically revert back to the standard time and temperature display.

At anytime, you may press the “ON/OFF”, “MODE”, “TIMER”, “SLEEP” or “TURBO” buttons to cancel the Sleep Mode 3

7)Indoor Fan Control

The indoor fan can be set to Ultra High, High, Med, Low and Auto with the remote controller.

In auto mode, the following speeds will be set:

Cooling Mode

- $T_{\text{indoorambient}} \geq T_{\text{setpoint}} + 2^{\circ} \text{ F}$, fan will run on high speed
- $T_{\text{setpoint}} - 2^{\circ} \text{ F} < T_{\text{indoorambient}} < T_{\text{setpoint}} + 2^{\circ} \text{ F}$, fan will run on medium speed
- $T_{\text{indoorambient}} \leq T_{\text{setpoint}} - 2^{\circ} \text{ F}$, fan will run on low speed

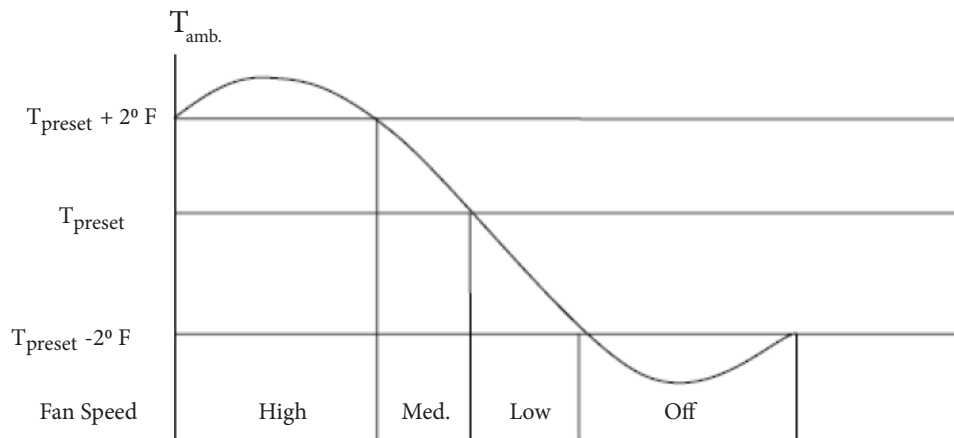

Product Introduction

System Operation 9,000/12,000 btuh Models, cont.

Other Controls

Fan Only "Auto" Mode

- a) $T_{\text{indoorambient}} > T_{\text{setpoint}} + 4^{\circ}\text{F}$, fan will run on high speed
- b) $T_{\text{setpoint}} + 2^{\circ}\text{F} \leq T_{\text{indoorambient}} \leq T_{\text{setpoint}} + 4^{\circ}\text{F}$, fan will run on medium speed
- c) $T_{\text{indoorambient}} < 2^{\circ}\text{F}$ of T_{setpoint} , fan will run on low speed

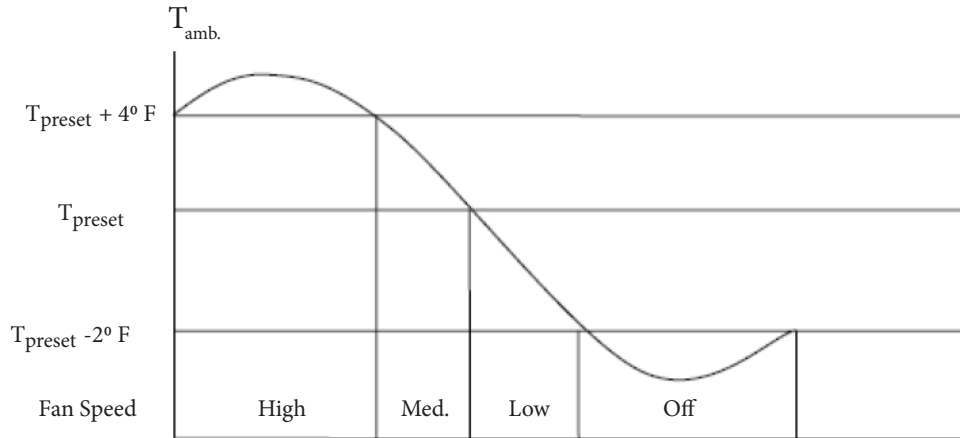

Dry Mode

The indoor fan will be set to low speed.

Heating Mode

- a) $T_{\text{indoorambient}} \leq T_{\text{setpoint}} + 1^{\circ}\text{F}$, fan will run on high speed
- b) $T_{\text{setpoint}} + 1^{\circ}\text{F} < T_{\text{indoorambient}} < T_{\text{setpoint}} + 5^{\circ}\text{F}$, fan will run on medium speed
- c) $T_{\text{indoorambient}} \geq T_{\text{setpoint}} + 2^{\circ}\text{F}$, fan will run on low speed

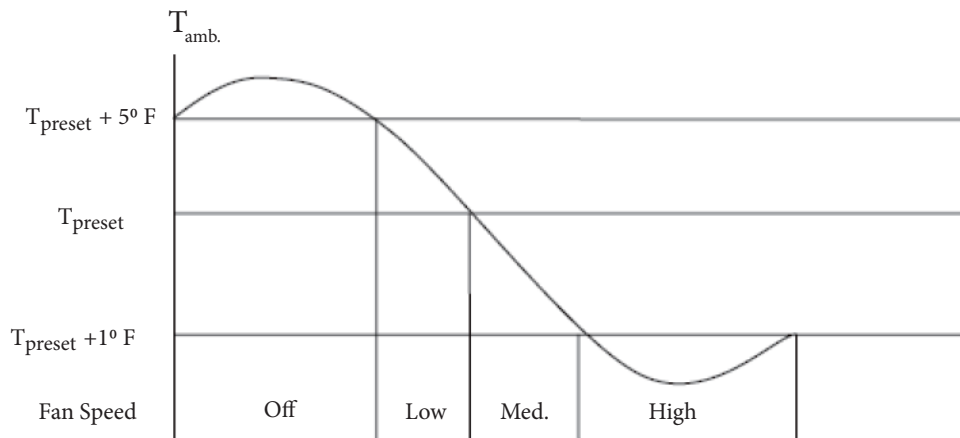

Product Introduction

System Operation 9,000/12,000 btuh Models, cont.

Other Controls

8) Buzzer Control

The buzzer control will send a “Tone” when the air conditioner is powered-up or received information sent by the remote control. You will also hear the tone when there is a button input or if the indoor unit doesn’t receive a signal from the remote controller in the Heat Mode.

9) Auto Button (Manual Override) - Located on indoor unit.

In the event the controller is missed placed or the batteries are defective, this will override the remote controller. If the controller is on, pressing this button will stop it, if it is off, pressing the button will turn the controller on. When turning the controller on, the swing and light will be on and the unit will run based on the remote controller setting.

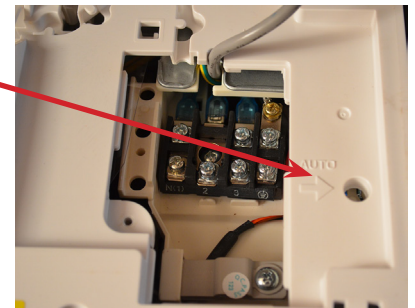

10) Swing Control

Vertical Swing

During power-up, the vertical swing motor will move the horizontal louver counter clockwise and close the air deflector. In Heating and Auto/Heat mode, the air deflector will move to position “D” if no swing mode is set. In Cooling mode the louver will move to L1. All other positions can be set by pressing the appropriate button to change the swing location.

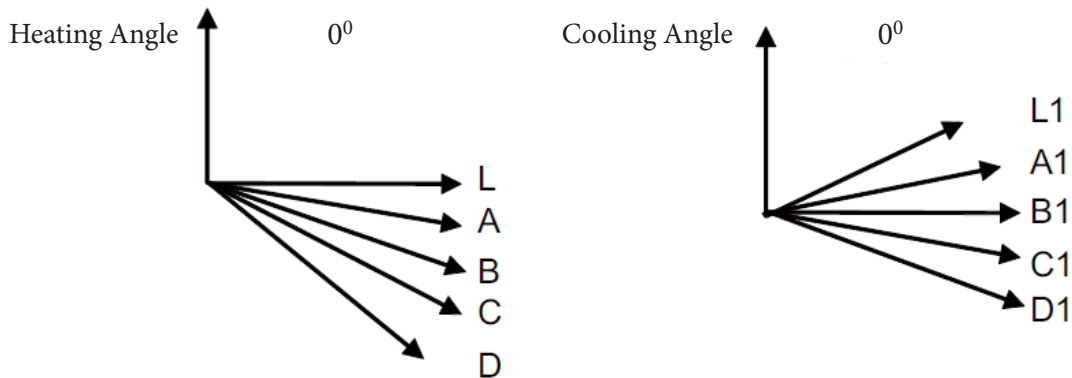

Horizontal swing

During power-up, the vertical louver will be reset to the start position and then stop in the middle position. There are 7 positions that the horizontal swing can be set including automatic swing and stopping between position 1 & 5.

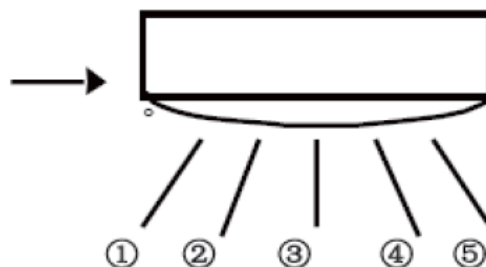

Product Introduction

System Operation 9,000/12,000 btuh Models, cont.

Other Controls

11) Display

1. Operational and Mode Display

All the display patterns will display for a time when the power is on, the operation pattern will display in red under standby status. When the unit is started by the remote controller, the indication pattern will light and display the current operation. You can turn off the display by pressing the “Light” button on the remote controller.

2. Indoor Unit Display

Depending on the settings on the remote controller, the Indoor Unit LED display may display the current temperature setpoint and indoor ambient temperature. “H1” will be displayed during the defrost cycle.

12) Drying Function (XFan)

The indoor fan will run for 10 minutes after the unit is turned off (cooling or dry modes only) to ensure that additional moisture is removed from the coil.

13) Power-Off Memory Function

Upon a power failure the mode of operation, swing function, light, set temperature and fan speed will retain memory. The unit will restart when recovering from a power interruption to the memory saved before the interruption occurred. If the power interruption occurs during a timed mode, the time left will not be remembered and will start to recount from the beginning. There will be a 3 minute compressor delay before resuming.

14) Outdoor Compressor and Condenser Heating Band Control

Under normal conditions, the control logic of the Electric Heating Bands will be as follows:

1. Control of Compressor Electric Heating Band

- a) Conditions for startup: The compressor is off and outdoor ambient $\leq 23^{\circ}$ F
- b) Conditions for turning off: Compressor operating, Compressor off and outdoor ambient $\geq 28^{\circ}$ F
- c) Band will turn off if the outdoor ambient temperature sensor has a malfunction.

2. Control of Condenser Electric Heating Band

- a) Condenser Band will be on if the Outdoor Ambient $\leq 34^{\circ}$ F
- b) During defrost operation, the heater band will operate 3 minutes after the compressor starts operating. When the compressor has operated for 3 minutes and the outdoor ambient $\geq 38^{\circ}$ F, the band will be de-energized.
- c) Electric band will be de-energized when the outdoor ambient $\geq 38^{\circ}$ F
- d) When 34° F < outdoor Ambient < 38° F, the electric heater band will keep its previous status.

If the outdoor sensor has a malfunction, the Electric Heating Band will be de-energized. It will have a 2 minute delay before it can be started again.

Product Introduction

System Operation 18,000/24,000 btuh Models

Basic Functions

The compressor should stay off for at least 3 minutes before starting the unit. The compressor circuit has a 3 minute delay if the compressor is de-energized during a run cycle. If the compressor starts from a de-energized cycle, there will be no time delay. The compressor has a minimum run time of 6 minutes regardless of room temperature.

1) Cooling Mode

Cooling Process

When the indoor ambient rises 5° F above the preset temperature, the unit will start the cooling cycle. The outdoor fan and compressor will start. The indoor fan will run continuously at the selected speed. The outdoor unit will monitor the appropriate temperatures and pressure and adjust the compressor speed and the EEV as required. If the indoor ambient is $> 5^{\circ}$ F then the preset temperature, the compressor speed will increase; $< 5^{\circ}$ F the compressor will begin reducing its speed. The G10 technology will control compressor speed based on indoor load and compressor amperage. When the indoor temperature is satisfied, the compressor will stop, then 30 seconds later the outdoor fan will stop.

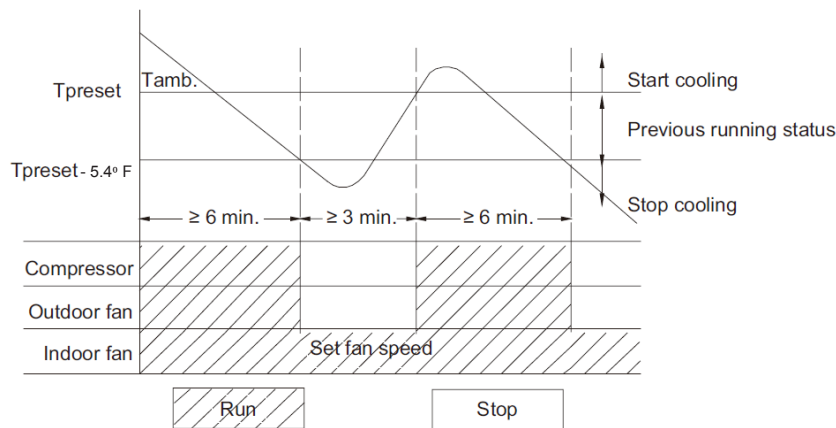

Evaporator Freeze Protection

The software will monitor the indoor evaporator coil for freezing.

In Cooling or Dry mode, if the Indoor tubes are $< 32^{\circ}$ F, for 3 consecutive minutes, the compressor will stop. The compressor will start when the tubes are above the calculated temperature limit. If the indoor tubes are $< 43^{\circ}$ F, the compressor will adjust its speed as needed. If the unit has stopped 6 times repeatedly, the unit will stop and a fault code will be displayed. The unit will need to be turned off, then back on to reset. As the compressor runs in normal mode, the number of faults will be cleared, they may also be cleared by switching from fan mode to heat mode.

Overcurrent Protection

The software will monitor the compressor current to maintain it in a safety and operating range.

If the total current ≥ 17 amps, the compressor will stop and the indoor fan will stop after 30 seconds. The system can resume after a 3 minute startup delay.

Product Introduction

System Operation 18,000/24,000 btuh Models, cont.

Basic Functions

2) Dry Mode

Drying Process

This feature will not take the place of a dehumidifier, it is intended to dry the filter and slightly cool the air. If the indoor ambient temperature is greater than the preset temperature, the unit will enter the cooling and drying mode, in which case the compressor will operate and the indoor fan will run at a low speed. When the indoor ambient temperature is at or below the preset temperature, the unit will operate in its previous running state. When the indoor ambient drops to more than 3.6° F below the preset temperature the compressor will stop running, then 30 seconds later the outdoor fan will stop, the indoor fan will run at low speed.

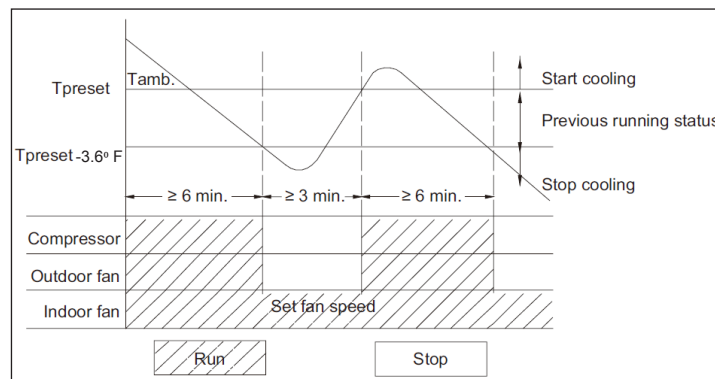

Overcurrent Protection (Same as Cooling Mode)

3) Heating Mode

Heating Process

When the indoor ambient drops 2° F below the preset temperature, the unit will start the heating cycle. The outdoor fan, compressor and 4-way valve will operate. The indoor fan will operate in the “Cold Air Prevention” mode in which the indoor fan will have a 2 minute delay after the call for heating. The indoor evaporator coil temperature must reach 104° F before the indoor fan will start, this will prevent cold air from discharging from the indoor coil. When the indoor evaporator coil temperature is $> 104^\circ \text{F}$, the indoor fan will operate at low speed for 1 minute. With 1 minute of operation or 2 minutes of no fan operation and the indoor evaporator coil temperature is $> 108^\circ \text{F}$, the indoor fan will operate at its preset condition.

If the indoor ambient temperature is $< 9^\circ \text{F}$ and $> 2^\circ \text{F}$ of the preset temperature, the unit will run in its original mode of operation.

If the compressor is running and the mode is changed from cooling to heating, the 4-way valve will be energized 2-3 minutes later.

If the indoor ambient temperature is $\geq 9^\circ \text{F}$ than the preset temperature, the compressor will stop and the outdoor fan will stop after a 30 second delay. The indoor fan will continue to operate at its preset mode.

The G10 technology will determine compressor frequency based on ambient temperatures.

Product Introduction

System Operation 18,000/24,000 btuh Models, cont.

Basic Functions

Heating Process, cont.

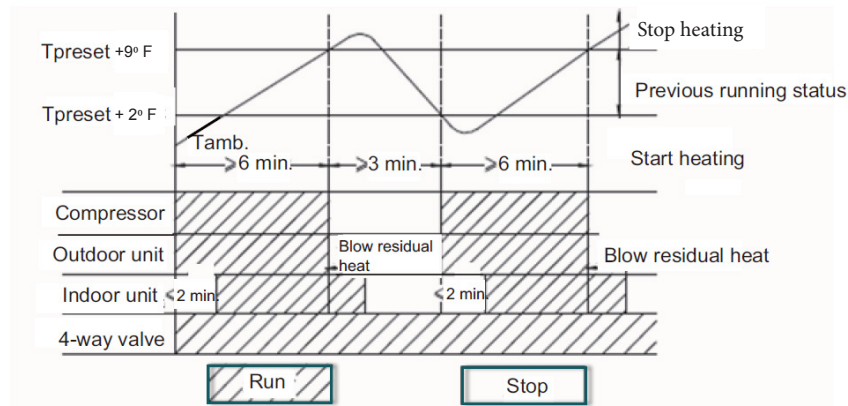

Defrost Process and Oil Return (Indoor display will indicate “H1”, this is not a fault code)

1) The unit will enter defrost when the following conditions are met:

- Outdoor ambient $\leq 41^{\circ}\text{F}$
- Compressor had accumulated more than 3 hours of operation in heating mode
- The outdoor coil $\leq 32^{\circ}\text{F}$

Note: The compressor run time will be cleared when the outdoor ambient is $> 41^{\circ}\text{F}$ or when the compressor has started up after changing to cooling or drying mode and defrost has finished. The run time will not be cleared when the unit has stopped after reaching the setpoint temperature, a protection fault or changing to fan mode.

There are 3 perimeters used in the defrost algorithms, Outdoor ambient ($T_{\text{outdoor ambient}}$), Outdoor tube ($T_{\text{outdoor tube}}$) and a calculated $T_{\text{compensation}}$

$T_{\text{compensation}}$ is calculated by the following:

- After energization, for the first defrost $T_{\text{compensation}} = 32^{\circ}\text{F}$
- $T_{\text{outdoor tube}} > 36^{\circ}\text{F}$ then $T_{\text{compensation}} = 32^{\circ}\text{F}$
- $T_{\text{outdoor tube}} \leq 36^{\circ}\text{F}$ then $T_{\text{compensation}} = 37^{\circ}\text{F}$

Product Introduction

System Operation 18,000/24,000 btuh Models, cont.

Basic Functions

Defrost Process, cont.

2) When heating has operated continuously for 45 minutes, or accumulated for 90 minutes, the unit will enter defrost mode in 3 minutes after meeting any of the conditions below:

- A. Outdoor ambient $\geq 41^{\circ}$ F and outdoor coil $\leq 28^{\circ}$ F
- B. 28° F $\leq T_{\text{outdoorambient}} < 41^{\circ}$ F, $T_{\text{outdoor tube}} \leq 21^{\circ}$ F
- C. 23° F $\leq T_{\text{outdoorambient}} < 28^{\circ}$ F $\leq T_{\text{outdoor tube}} \leq 18^{\circ}$ F
- D. 14° F $\leq T_{\text{outdoorambient}} < 23^{\circ}$ F, $T_{\text{outdoor tube}} - T_{\text{compensation}} \leq (T_{\text{outdoorambient}} - 37^{\circ}$ F)

3) During defrost, if run time for the compressor does not reach 3 minutes, the defrost cycle will not start for the next 2 hours. At that time the compressor stops operation and 30 seconds later the outdoor fan will stop. 30 seconds after this the 4-way reversing valve will de-energized. Following another 30 second delay, the compressor will increase its speed for defrosting. Defrosting will last for 450 seconds or until the $T_{\text{outdoor tube}} \geq 50^{\circ}$ F, at this temperature the compressor will decrease its speed for 30 seconds, then will stop. In another 30 seconds the 4-way valve will energize, the 60 seconds later the compressor and outdoor fan will start. The compressor speed for defrosting will be 85hz.

During Defrost mode, a H1 will be displayed on the indoor front panel display indicating the user selected mode has been overridden and the system is performing an outdoor coil defrost operation.

System Protection

Cold Air Prevention (Heating mode with compressor running)

The system guards against discharging cold air in heating mode. It will delay the indoor fan until the evaporator coil has warmed up to discharge warm, comfortable air into the room.

1) When the $T_{\text{indoor ambient}} < 75^{\circ}$ F and the $T_{\text{indoor tube}} \leq 104^{\circ}$ F with the fan in a stopped state, the indoor fan will begin to run at low speed after a 2 minute delay. This will reduce cold air upon heating startup. Within 2 minutes, if $T_{\text{indoor tube}} > 104^{\circ}$ F, the indoor fan will run at low speed. After 1 minute of operation, the fan will run at the preset fan mode. Within 1 minute of low speed operation or 2 minutes of no fan operation, with the $T_{\text{indoor tube}} > 108^{\circ}$ F, the fan will run at the preset mode.

2) If the $T_{\text{indoor ambient}} \geq 75^{\circ}$ F and the $T_{\text{indoor tube}} \leq 108^{\circ}$ F the indoor fan will run at low speed for 1 minute than run at the preset mode. After 1 minute of low speed operation, if the and the $T_{\text{indoor tube}} > 108^{\circ}$ F the fan will operate at its preset mode.

Note:

The $T_{\text{indoor ambient}}$ in 1 & 2 above refers to the unit going into the heating mode, coming out of defrost.

Overcurrent and Speed Protection (Total Current = I_{total})

The software will monitor the compressor current draw and adjust the compressor speed in order to maintain the inverter and compressor in a safety and reliable operating range.

- A. If $I_{\text{total}} \leq 13$, an increase or decrease in frequency will be allowed
- B. If $I_{\text{total}} > 13$ and < 17 , frequency will remain the same
- C. If $I_{\text{total}} \geq 17$, the compressor will stop and the indoor fan will stop after 30 seconds

4) Fan Mode

Under this mode, the fan will run at the preset speed and the outdoor fan, compressor and 4-way valve will stop.

Product Introduction

System Operation 18,000/24,000 btuh Models, cont.

Basic Functions

5) Auto Mode

Auto Mode Process

Setting the auto mode will run the unit in heat or cool automatically depending on $T_{\text{indoorambient}}$

1) Operating Parameters

- A. If the $T_{\text{indoorambient}} \geq 79^{\circ}\text{F}$ the unit will operate in cooling mode. The set temperature is 77°F .
- B. If the $T_{\text{indoorambient}} \leq 72^{\circ}\text{F}$ the unit will operate in heat mode. The set temperature is 68°F .
- C. When the $T_{\text{indoorambient}} \leq 73^{\circ}\text{F}$ and $\geq 77^{\circ}\text{F}$, the unit will operate in the previous state. If it is energized for the first time, it will run in Fan mode
- D. In auto mode, the cooling frequency will be the same as the cooling only mode and the heating frequency will be the same as the heating only mode.

2) Protection

- A. In cooling operation, protection is the same as the cooling only mode
- B. In heating operation, protection is the same as the heating only mode
- C. When the indoor ambient temperature changes, the operation mode will be automatically selected. Once started the compressor will have a 6 minute run time.

Product Introduction

System Operation 18,000/24,000 btuh Models, cont.

Basic Functions

6) Common Protection Functions and Fault Displays

Overload Protection

T_{tube} = measured temperature of outdoor coil in cooling mode, measured temperature of indoor coil in heating mode.

1) **Outdoor Coil High Temperature Protection** - *In cooling mode the software will monitor the outdoor coil for an abnormal high temperature condition.*

- A. If $T_{\text{tube}} \leq 126^{\circ}$ F, the unit will return to its original operation state
- B. If $T_{\text{tube}} \geq 131^{\circ}$ F, frequency rise is not allowed
- C. If $T_{\text{tube}} \geq 136^{\circ}$ F, the compressor will run at reduced frequency
- D. If $T_{\text{tube}} \geq 144^{\circ}$ F, the compressor will stop and the indoor fan will operate at preset speed

2) **Indoor Coil Temperature Protection** - *In heating mode the software will monitor the indoor coil for an abnormal high temperature condition.*

- A. If $T_{\text{tube}} \leq 122^{\circ}$ F, the unit will return to its original operation state
- B. If $T_{\text{tube}} \geq 127^{\circ}$ F, frequency rise is not allowed
- C. If $T_{\text{tube}} \geq 133^{\circ}$ F, the compressor will run at reduced frequency
- D. If $T_{\text{tube}} \geq 140^{\circ}$ F, the compressor will stop and the indoor fan will blow residual heat and then stop

3) Compressor Discharge Temperature Protection

The software will monitor the compressor discharge for an abnormal high temperature condition.

- A. If $T_{\text{tube}} \geq 208^{\circ}$ F, frequency rise is not allowed
- B. If $T_{\text{tube}} \geq 217^{\circ}$ F, the compressor will run at reduced frequency
- C. If $T_{\text{tube}} \geq 230^{\circ}$ F, the compressor will stop
- D. If $T_{\text{tube}} \leq 194^{\circ}$ F and the compressor has been off for at least 3 minutes, the compressor will resume operation

Communication Fault

If the unit fails to receive correct signals for a 3 minutes, communication fault will occur and the whole system will stop and a E6 will be displayed on the front panel of the indoor unit.

Module Protection

Under module protection mode, the compressor will stop. When the compressor remains off for 3 minutes, the compressor will resume operation. If the module protection occurs six time in succession, the compressor will remain off. This is a thermal protection for the indoor module (AP1).

Compressor Protection

If temperature sensed by the overload sensor is over 239° F, the compressor will stop and the outdoor fan will stop after 30 seconds. When the temperature is below 203° F, the overload protection will reset to normal state.

DC Buss Voltage Protection - *The software will monitor the inverter DC bus voltage.*

If voltage on the DC Bus is below 150 or over 420v, the compressor will stop and the outdoor fan will stop in 30 seconds. When the voltage on the DC bus returns to normal and the compressor has been off for 3 minutes, the compressor will resume its operation.

Product Introduction

System Operation 18,000/24,000 btuh Models, cont.

Other Controls

1) On/Off

The on-off state will change with each button press.

2) Mode Selection

Press the "Mode" button to change from Auto, Cool, Dry, Fan or Heat Pump

3) Temperature Setting

Each time you press the "TEMP+" or "TEMP-" button the temperature setting will change by 1° F. The temperature range is 61° F - 86° F. In Auto Mode this button will not function.

4) Time Switch

The unit will stop and start by setting the Timer on the remote controller.

5) Energy Savings Mode (Press Temp & Clock simultaneously, display will indicate "SE")

In heating mode, refer to the Cold Air Prevention explained in the (3) Heating Mode process .

In cooling mode, the fan speed will adjust according to the fan speed curve below:

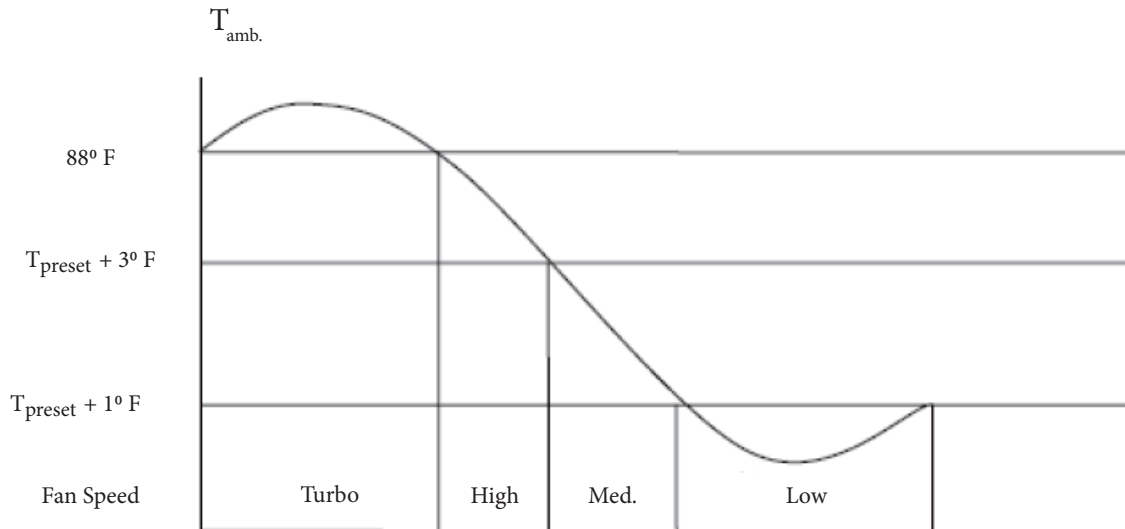

Product Introduction

System Operation 18,000/24,000 btuh Models, cont.

Other Controls

6) Sleep Control

The Terra has 3 Sleep mode settings to improve comfort and energy savings.

Auto Mode and Fan Mode do not utilize the Sleep Mode Settings

Sleep Mode 1 (Gradual Cycle)

1. Cool or Dry Mode

a) After 1 hour of operation the temperature setting will raise 2° F

b) After 2 hours of operation the temperature setting will increase 4° F and stay at this setting until the sleep mode is canceled

2. Heat Mode

a) After 1 hour of operation the temperature setting will decrease 2° F

b) After 2 hours of operation the temperature setting will decrease 4° F and stay at this setting until the sleep mode is canceled

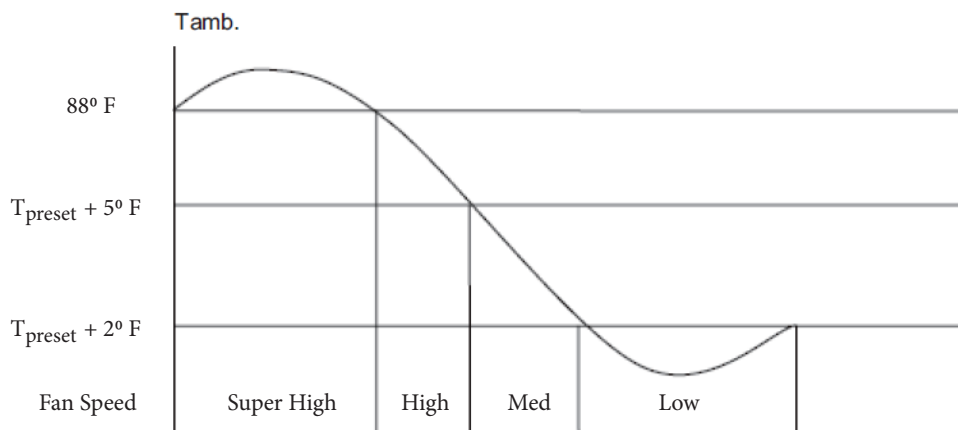

Product Introduction

System Operation 18,000/24,000 btuh Models, cont.

Other Controls

Sleep Mode 2 (Adaptive Cycle)

1. Cool or Dry Mode (Initial setpoint between 61° F. - 74° F.)
 - a) After 1 hour of operation the temperature setting will raise 2° F every hour
 - b) After 3 hours of operation the temperature setting will raise 6° F above initial setpoint and stay at this setting
 - c) After 7 hours of operation, the setpoint will move to 4° F. above the initial setpoint and remain until the sleep mode is canceled.
- Cool or Dry Mode (Initial setpoint between 75° F. - 81° F.)
 - a) After 1 hour of operation the temperature setting will raise 2° F every hour
 - b) After 3 hours of operation the temperature setting will raise 4° F above initial setpoint and stay at this setting
 - c) After 7 hours of operation, the setpoint will move to 2° F. above the initial setpoint and remain until the sleep mode is canceled.
- Cool or Dry Mode (Initial setpoint between 82° F. - 85° F.)
 - a) After 1 hour of operation the temperature setting will raise 2° F every hour
 - b) After 3 hours of operation the temperature setting will raise 24° F above initial setpoint and stay at this setting
 - c) After 7 hours of operation, the setpoint will move back to the initial setpoint and remain until the sleep mode is canceled.
- Cool or Dry Mode (Initial setpoint above 85° F.)
 - a) The original setpoint will be maintained for 7 hours, then after 7 hours it will decrease by 1° F until the sleep mode is canceled
2. Heat Mode (Initial setpoint 61° F.)
 - a) The unit will maintain this setpoint until Sleep Mode is canceled
- Heat Mode (Initial setpoint between 62° F. - 68° F.)
 - a) After 1 hour of operation the temperature setting will decrease 2° F and maintain this setpoint until Sleep Mode is canceled
- Heat Mode (Initial setpoint between 69° F. - 81° F.)
 - a) After 1 hour of operation the temperature setting will decrease 2° F and maintain this setpoint until Sleep Mode is canceled
- Heat Mode (Initial setpoint between 82° F. - 86° F.)
 - a) After 1 hour of operation the temperature setting will decrease 2° F every hour
 - b) After 3 hours, the setpoint will be fixed at 6° F below the initial setpoint and remain at this setpoint until Sleep Mode is canceled

Product Introduction

System Operation 18,000/24,000 btuh Models, cont.

Other Controls

Sleep Mode 3 (Customized Cycle)

You will be required to enter 8 room setpoint values for 8 hours of runtime. The last room setpoint value will be maintained until Sleep Mode is canceled.

In Sleep Mode 3, press the “Turbo” button to enter setup mode. The remote controller will display “1:00” in the time location. Use the “+” and “-” buttons to select the desired room setpoint for the 1st hour of runtime, then press the “Turbo” button to save the data.

The remote controller will display “2:00”. Once again, use the “+” and “-” buttons to select the desired room setpoint for the second hour of run time. Press the “Turbo” button to save the data.

Repeat this procedure for the remaining hours (total of 8). After all 8 settings have been saved, the remote controller will automatically revert back to the standard time and temperature display.

At anytime, you may press the “ON/OFF”, “MODE”, “TIMER”, “SLEEP” or “TURBO” buttons to cancel the Sleep Mode 3

7) Indoor Fan Control

The indoor fan can be set to Ultra High, High, Med, Low and Auto with the remoter controller.

In auto mode, the following speeds will be set:

Cooling Mode

- $T_{\text{indoorambient}} \geq T_{\text{setpoint}} + 2^{\circ} \text{F}$, fan will run on high speed
- $T_{\text{setpoint}} - 2^{\circ} \text{F} < T_{\text{indoorambient}} < T_{\text{setpoint}} + 2^{\circ} \text{F}$, fan will run on medium speed
- $T_{\text{indoorambient}} \leq T_{\text{setpoint}} - 2^{\circ} \text{F}$, fan will run on low speed

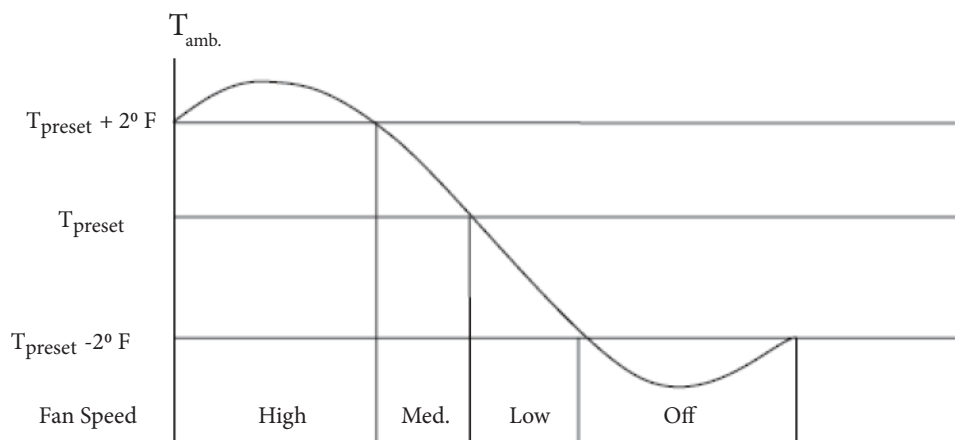

Product Introduction

System Operation 18,000/24,000 btuh Models, cont.

Other Controls

7) Indoor Fan Control, cont.

Fan Only “Auto” Mode

- a) $T_{\text{indoorambient}} > T_{\text{setpoint}} + 4^{\circ} \text{ F}$, fan will run on high speed
- b) $T_{\text{setpoint}} + 2^{\circ} \text{ F} \leq T_{\text{indoorambient}} \leq T_{\text{setpoint}} + 4^{\circ} \text{ F}$, fan will run on medium speed
- c) $T_{\text{indoorambient}} < 2^{\circ} \text{ F of } T_{\text{setpoint}}$, fan will run on low speed

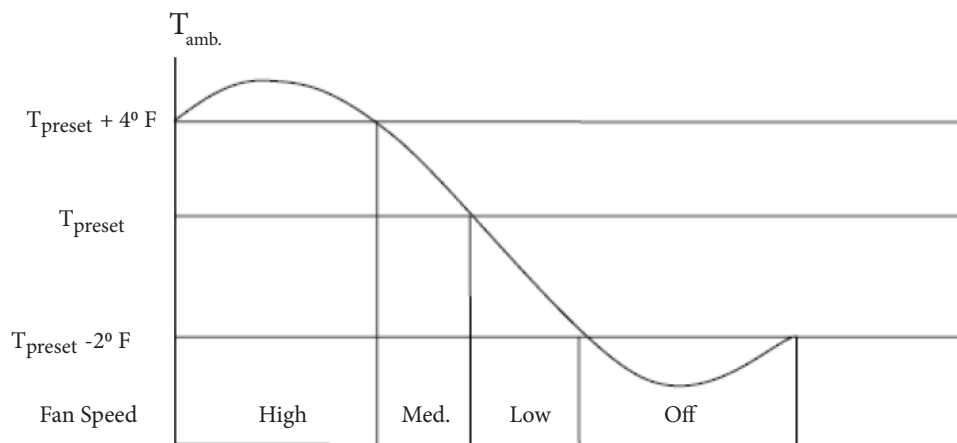

Dry Mode

The indoor fan will be set to low speed.

Heating Mode

- a) $T_{\text{indoorambient}} \leq T_{\text{setpoint}} + 1^{\circ} \text{ F}$, fan will run on high speed
- b) $T_{\text{setpoint}} + 1^{\circ} \text{ F} < T_{\text{indoorambient}} < T_{\text{setpoint}} + 5^{\circ} \text{ F}$, fan will run on medium speed
- c) $T_{\text{indoorambient}} \geq T_{\text{setpoint}} + 2^{\circ} \text{ F}$, fan will run on low speed

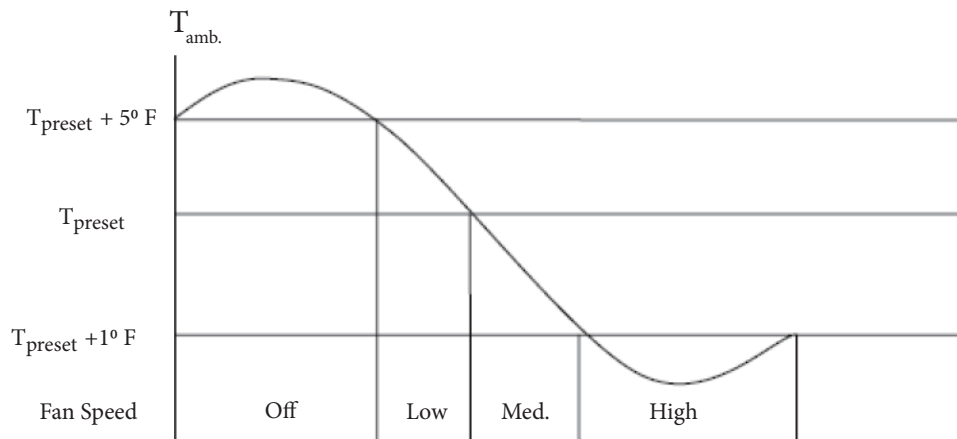

Product Introduction

System Operation 18,000/24,000 btuh Models, cont.

Other Controls

8) Buzzer Control

The buzzer control will send a “Tone” when the air conditioner is powered-up or received information sent by the remote control. You will also hear the tone when there is a button input or if the indoor unit doesn’t receive a signal from the remote controller in the Heat Mode.

9) Auto Button (Manual Override) - Located on indoor unit.

In the event the controller is missed placed or the batteries are defective, this will override the remote controller. If the controller is on, pressing this button will stop it, if it is off, pressing the button will turn the controller on. When turning the controller on, the swing and light will be on and the unit will run based on the remote controller setting.

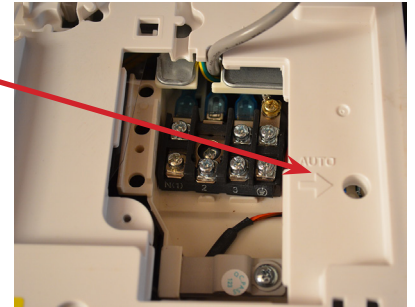

10) Swing Control

Vertical Swing

During power-up, the vertical swing motor will move the horizontal louver counter clockwise and close the air deflector. In Heating and Auto/Heat mode, the air deflector will move to position “D” if no swing mode is set. In Cooling mode the louver will move to L1. All other positions can be set by pressing the appropriate button to change the swing location.

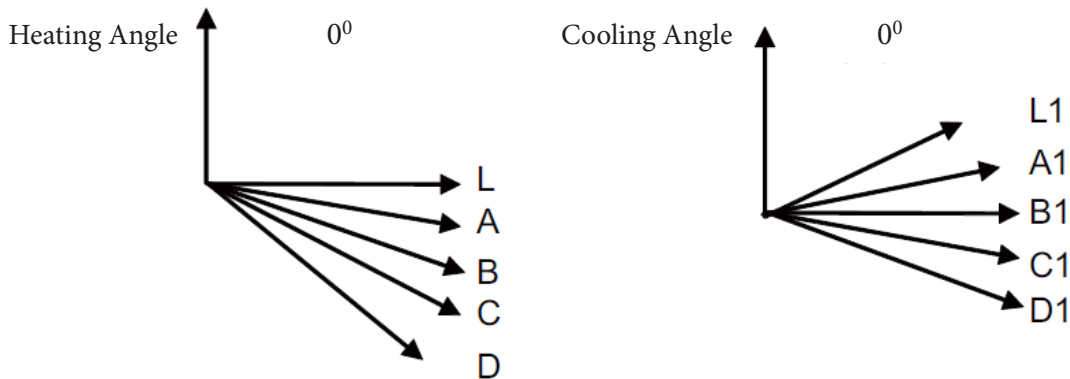

Horizontal swing

During power-up, the vertical louver will be reset to the start position and then stop in the middle position. There are 7 positions that the horizontal swing can be set including automatic swing and stopping between position 1 & 5.

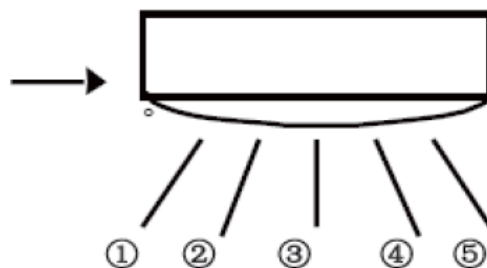

Product Introduction

System Operation 18,000/24,000 btuh Models, cont.

Other Controls

11) Display

1. Operational and Mode Display

All the display patterns will display for a time when the power is on, the operation pattern will display in red under standby status. When the unit is started by the remote controller, the indication pattern will light and display the current operation. You can turn off the display by pressing the “Light” button on the remote controller.

2. Indoor Unit LED Display

Depending on the settings on the remote controller, the indoor unit LED display may display the current temperature set-point and indoor ambient temperature. “H1” will be displayed during the defrost cycle.

12) Drying Function

The indoor fan will run for 10 minutes after the unit is turned off (cooling or dry modes only) to ensure that additional moisture is removed from the coil.

13) Power-Off Memory Function

Upon a power failure the mode of operation, swing function, light, set temperature and fan speed will retain memory. The unit will restart when recovering from a power interruption to the memory saved before the interruption occurred. If the power interruption occurs during a timed mode, the time left will not be remembered and will start to recount from the beginning. There will be a 3 minute compressor delay before resuming.

14) Outdoor Compressor and Condenser Heating Band Control

Under normal conditions, the control logic of the Electric Heating Bands will be as follows:

1. Control of Compressor Electric Heating Band

- a) Conditions for startup: The compressor is off and outdoor ambient $\leq 23^{\circ}$ F
- b) Conditions for turning off: Compressor operating, Compressor off and outdoor ambient $\geq 28^{\circ}$ F
- c) Band will turn off if the outdoor ambient temperature sensor has a malfunction.

2. Control of Condenser Electric Heating Band

- a) Condenser Band will be on if the Outdoor Ambient $\leq 34^{\circ}$ F
- b) During defrost operation, the heater band will operate 3 minutes after the compressor starts operating. When the compressor has operated for 3 minutes and the outdoor ambient $\geq 37^{\circ}$ F, the band will be de-energized.
- c) Electric band will be de-energized when the outdoor ambient $\geq 37^{\circ}$ F
- d) When 34° F < outdoor Ambient < 37° F, the electric heater band will keep its previous status.

If the outdoor sensor has a malfunction, the Electric Heating Band will be de-energized. It will have a 2 minute delay before it can be started again.

Remote Control Operation

Remote Buttons

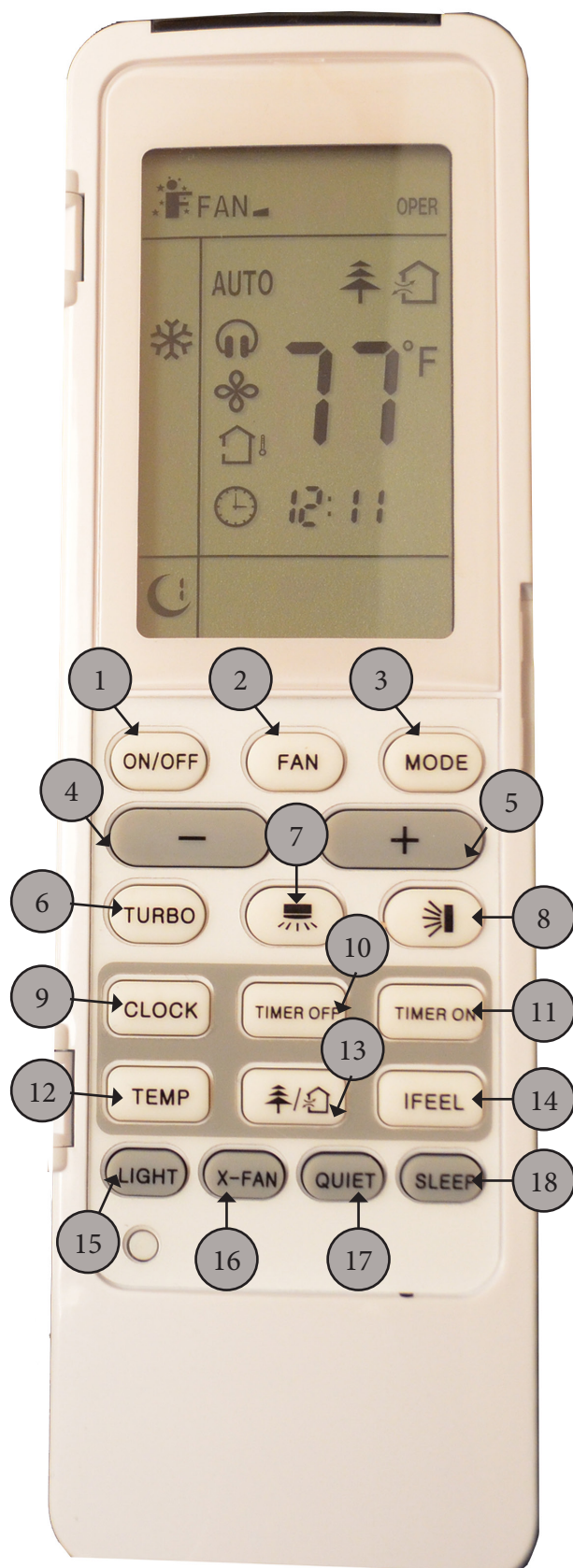

Note:

This remote control is used in other models and some features may or may not be available. Consult the owners manual for specific features for your model. There should be no obstructions between the remote control and the indoor unit for proper operation. Keep the remote from direct sunlight or any source that generates heat, keep clean and dry. Change batteries frequently.

Note:

For detailed explanation of the functions, refer to the “Other Controls” section of this manual for your model.

Button Identification

The function and operation of each button will be explained later in this manual under Product Functions.

1. On/Off button
2. Fan Button
3. Mode Button
4. Lower Temperature Setting
5. Raise Temperature Setting
6. Turbo Fan Speed Button
7. Horizontal Swing Louver
8. Vertical Swing Louver
9. Clock Button, press to set time
10. Timer Off, press to set auto-off timer
11. Timer On, press to set auto-on timer
12. Change Display temperature reading from Set-point, Indoor or Outdoor Temperature reading
13. Health & Static De-Dusting Button
14. IFeel Button
15. Remote Display light
16. X-fan button
17. Quiet mode, available in Heat or Cool mode only
18. Sleep Button

Press 9 & 10 for Energy Saving Mode

Press - & + to lock control

Remote Control Operation

Display Icons

1. IFeel
2. Auto Mode
3. Cool Mode
4. Dry Mode
5. Fan Mode
6. Heat Mode
7. Sleep Mode
8. Quiet Mode
9. X-Fan Mode
10. Display Temperature Mode
11. Timer On
12. Display Light
13. Horizontal Louvers
14. Vertical Louvers
15. Lock Control
16. Fan Setting
17. Energy Saving Mode
18. Turbo Mode
19. Health Mode
20. Static Dedusting
21. Timer Setting

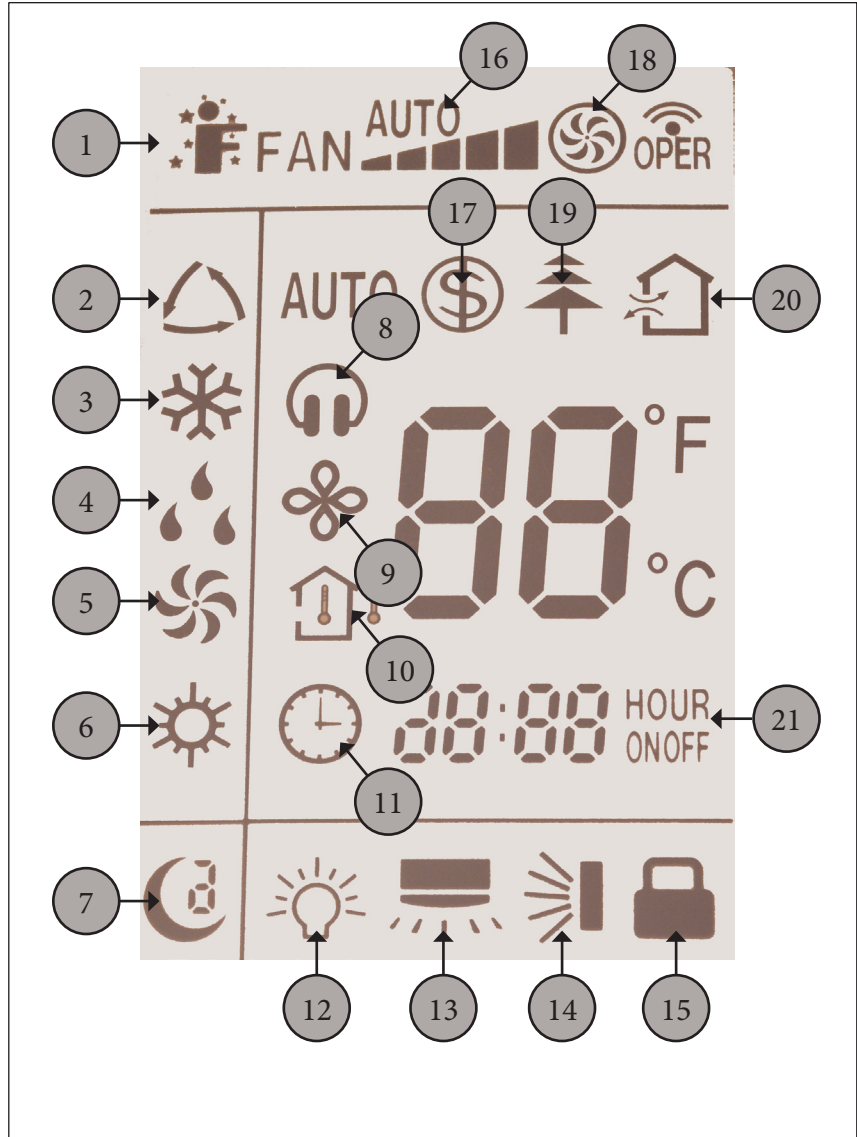

Refrigerant Lines Connection, Evacuating and Charging

Refrigerant Lines Preparation & Connection

The refrigerant lines should be kept sealed until ready to be connected. Follow the following steps to insure a quality leak proof installation:

Step 1. Refrigerant Line Connection

Carefully bend and cut the tubing to prepare for flaring. Use a flaring tool designed for R410a, following the recommended manufacturer's procedure. Tighten the flare nut to the indicated torque by using a spanner wrench and a torque wrench. Connect the indoor unit first, then the outdoor unit.



Note:

Over tightening flare nuts may damage flare connections and may cause leaks.

Tubing Size	Torque (foot-pounds)	Torque (inch-pounds)
1/4"	10-13	124-159
3/8"	25-31	301-372
1/2"	36-45	434-540
5/8"	50-60	602-726

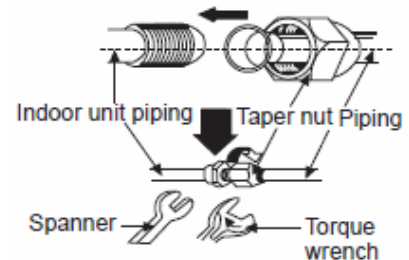

Step 2. System Leak Check

Refrigerant lines should be pressurized prior to evacuating system to check for leaks.

Use only dry nitrogen with a pressure regulator for pressurizing unit. Pressurize with 150 psi of dry nitrogen. Apply soap and water to check whether the joints are leaky. A leak detector may also be used for a leakage test.

Hint:

You may want to perform leak testing and evacuation before wiring to save time, electrical connections can be completed while your vacuum pump is running.



Step 3. System Evacuation

Note: The outdoor unit contains a refrigerant charge, leave liquid and gas valves closed.

1. After no leaks have been detected, connect a vacuum pump to the outdoor unit.
2. Connect appropriate hoses to manifold gauge, vacuum pump and unit refrigeration connections.
3. Evacuate the system until the micron gauge reads no higher than 350 microns.
4. Close valve to vacuum pump; if pressure does not rise above 500 microns after one minute, the evacuation should be complete.
5. If it does rise, check for leaks and/or evacuate longer.
6. For refrigerant lines longer than 25 feet, refer to installation instructions chart included with the unit installation manual for additional charge.



Refrigerant Charging Procedure

Please refer to your units installation manual for proper charge. If your lineset exceeds 25', additional charge will be required. The charge must be weighed in with a refrigerant charging scale.

1. Determine additional refrigerant charge.

Multiply refrigerant charge per ft by total tubing length - 25.

Example:

35' of installed tubing, installation manual requires additional .24 ounces per foot.

$35 - 25 = 10$ additional ft. x $.24 = 2.4$ ounces to be added

2. Adding additional refrigerant charge.

Remove the suction port cap on the valve, then attach a 5/16" F x 1/4" M adapter to the suction port. Connect your low side hose to the 1/4" F fitting.

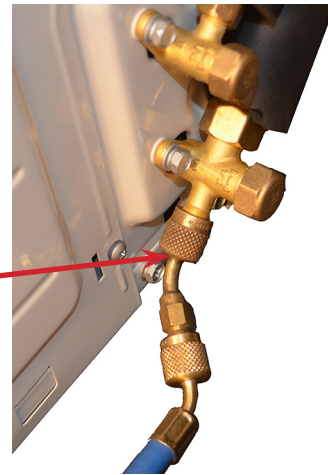

3. Attach refrigerant tank to hose

Close all valves on your gauge set, then connect the correct refrigerant tank to the charging hose.



4. Zero charging scale

Place the refrigerant tank on the charging scale. Open the tank valve, turn on the scale, then zero the scale.



Refrigerant Charging Procedure, cont.

5. Begin adding additional refrigerant

Open the low side manifold valve to begin the charging process. Unit should be charged in liquid state.

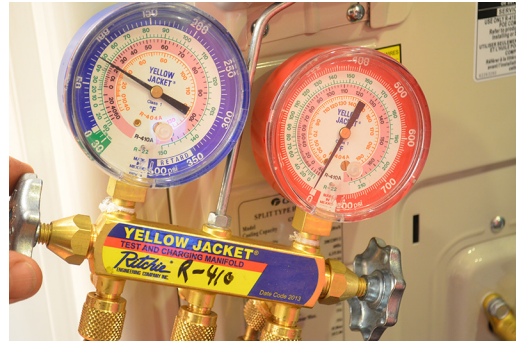

6. Charge to the correct weight

If the scale was zeroed with the refrigerant tank on the scale, the amount added to the system will be a negative amount since it was removed from the tank. After the proper amount of refrigerant has been weighed in, close the low side manifold valve.



3. Remove refrigerant tank

Close the tank valve, then carefully remove the hose and adapter. Replace the suction port cap on the outdoor unit suction valve. If this is a new installation, follow proper procedure in opening valves.



Installation

Proper installation site is vital for correct and efficient operation of the unit. Avoid the following sites where:

- Strong heat sources, vapors, flammable gas or volatile liquids are emitted.
- High-frequency electro-magnetic waves are generated by radio equipment, welders and medical equipment.
- The air is contaminated with industrial vapors and oils.
- The air contains sulfurous gas such as in hot spring zones.
- Poor air quality exists.

Indoor Unit



The air inlet and outlet should be away from any obstructions. Ensure the air will easily circulate through the entire room.

1. Select a site where the condensate can be easily routed or consider a condensate removal pump.
2. Select a place where it is out of reach of children.
3. Select a place that has adequate mounting structure, strong enough to withstand the full weight and vibration of the unit.
4. Be sure to leave enough space to allow access for routine maintenance. Refer to unit installation specifications for clearances. Select a place more than 3 feet away from any TV or other electrical appliances

Outdoor Unit



1. Select a suitable site where proper drainage will occur.
2. Select a site where there is sufficient ventilation.
3. Select a site where there is no obstruction blocking the inlet and outlet.
4. The site should be able to withstand the full weight of the unit.
5. Try to limit expose to direct sunlight or strong winds.
6. Make sure that the outdoor unit is installed in accordance with the installations instructions, and is convenient for maintenance and repair.
7. Refer to your outdoor unit installation manual for maximum lineset lengths and heights. This could be a factor in determining outdoor location.
8. Select a place where it is out of reach of children.
9. Install Heat Pump legs to allow for proper drainage.
10. Install drain fitting in bottom of outdoor unit



Installation

Mounting Plate Installation



1. The mounting plate should be installed horizontally and level.
2. Measure the center of the indoor unit. Please note, that depending on model, the center of the bracket may not correspond with the center of the unit.
3. Attach the mounting plate on the wall with screws.
4. Be sure that the mounting plate has been attached firmly enough to withstand approximately 132 pounds.
5. Refer to specific models for dimensional data.

Locate and Drill Hole



1. The piping can exit the indoor unit from either side, see pictured below.
2. Drill a 2-1/2" diameter hole at a slightly downward angle to the outdoor side.
3. Note: The outdoor hole should be approximately 1/4" lower than the indoor hole.
4. Insert the piping-hole sleeve into the hole to prevent the piping and wiring from being damaged when passing through the hole.

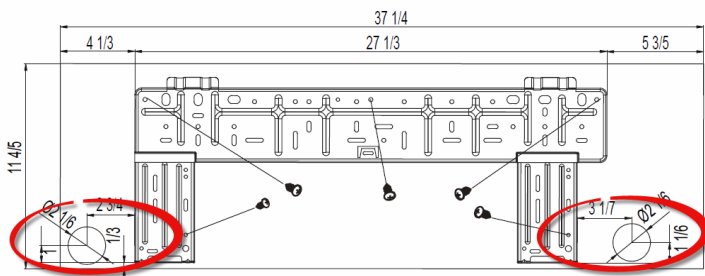

Installation

Install Drain Hose

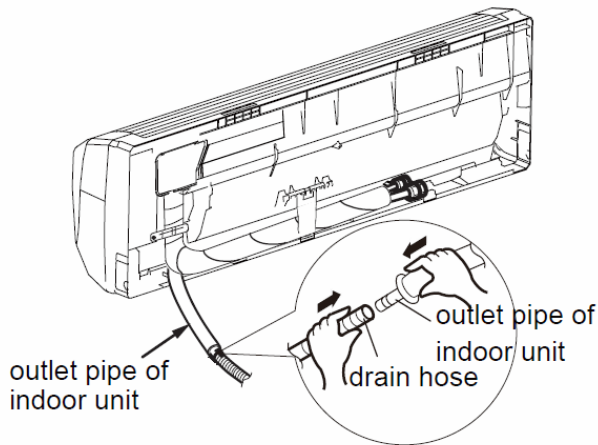

1. Connect the drain hose to the outlet pipe of the indoor unit using appropriate connections.
2. Insulate the condensate to prevent condensation.
3. Fasten the condensate, lineset and wiring together to prevent damage and movement. Slant the drain hose downward for smooth drainage.

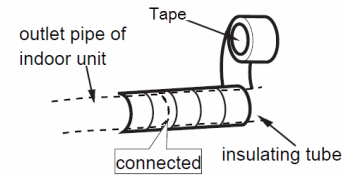
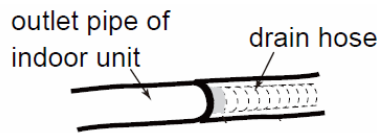

Install Line Set



1. Install lineset and wiring from the outside through the wall sleeve.
2. Bend the indoor lineset. Note: a tube bender will speed up the process.
3. Carefully remove flare nut from indoor coil. Listen for holding charge from indoor unit. No charge may indicate a leak and should be tested.
4. Use a flaring tool if necessary to create the flare, connect tubing tightening to the torque listed below.

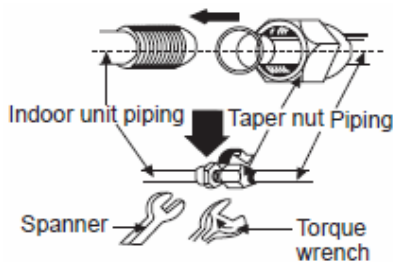

Tubing Size	Torque (foot-pounds)	Torque (inch-pounds)
1/4"	10-13	124-159
3/8"	25-31	301-372
1/2"	36-45	434-540
5/8"	50-60	602-726



Installation

Pressure and Leak Test

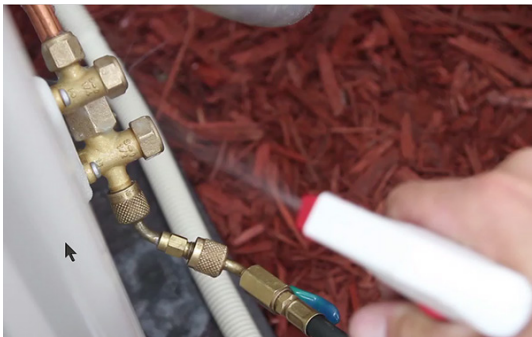
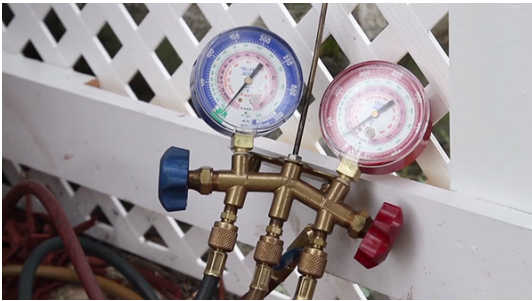

1. Use only dry nitrogen with a pressure regulator for pressurizing unit. Pressurize with 150 psi of dry nitrogen.
2. Apply soap and water to check whether the joints are leaky. A leak detector can also be applied for a leakage test.

Hint: You may want to perform leak testing and evacuation before wiring to save time, electrical connections can be completed while your vacuum pump is running.

Evacuating the System



Note: The outdoor unit contains a refrigerant charge, leave liquid and gas valves closed.

1. After no leaks have been detected, connect a vacuum pump to the outdoor unit.
2. Connect appropriate hoses to manifold gauge, vacuum pump and unit refrigeration connections.
3. Evacuate the system until the micron gauge reads no higher than 350 microns.
4. Close valve to vacuum pump; if pressure does not rise above 500 microns after one minute, the evacuation should be complete.
5. If it does rise, check for leaks and/or evacuate longer.
6. For refrigerant lines longer than 25 feet, refer to installation instructions chart included with the unit installation manual for additional charge.

Installation

Connect the Outdoor Wiring

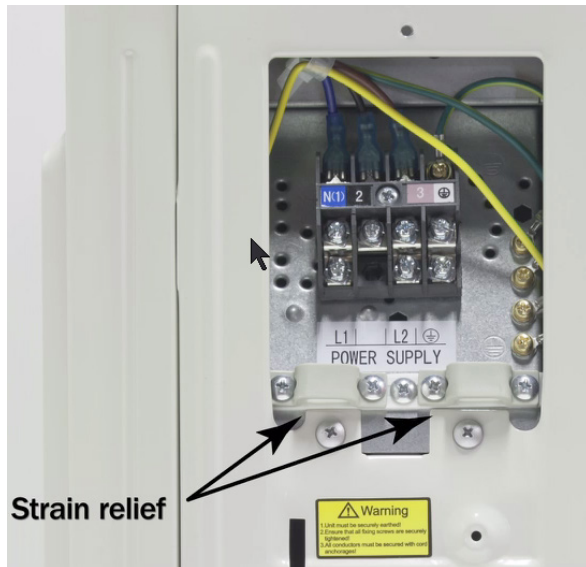

1. Remove the handle on the right side plate of the outdoor unit.
2. Connect power wiring from outdoor disconnect to L1, L2 and ground.
3. Connect wiring from indoor unit to 1,2,3 & ground, being careful to match color code of indoor connections. (Use 14-4 stranded wire)
4. Check all connections to tightness.
5. Reinstall the cover/handle.

Note: Follow all local electrical codes for electrical wiring.

Filter Maintenance and Emergency Operation

Cleaning Air Filter

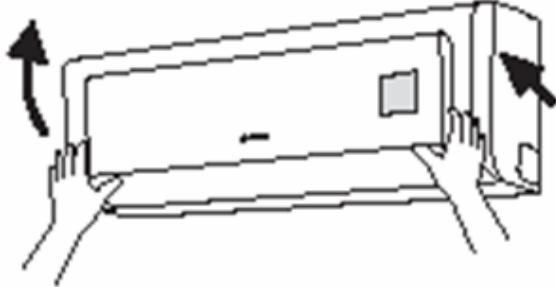

Titanium Dioxide filter
(2nd Stage Filter)



1. Remove the front panel as shown on the picture in the left.
2. The first stage filter can be cleaned with a vacuum cleaner or by washing with a mild soap and $< 113^{\circ}$ F water.
3. The second stage filter cannot be washed, use a vacuum cleaner to clean any dust, lint, etc. The filter is made up of Titanium Dioxide.
4. Recharge the Titanium Dioxide filter by placing it in the Sun for 3-4 hours every 3-6 months.

Missing or Inoperative Remote Control

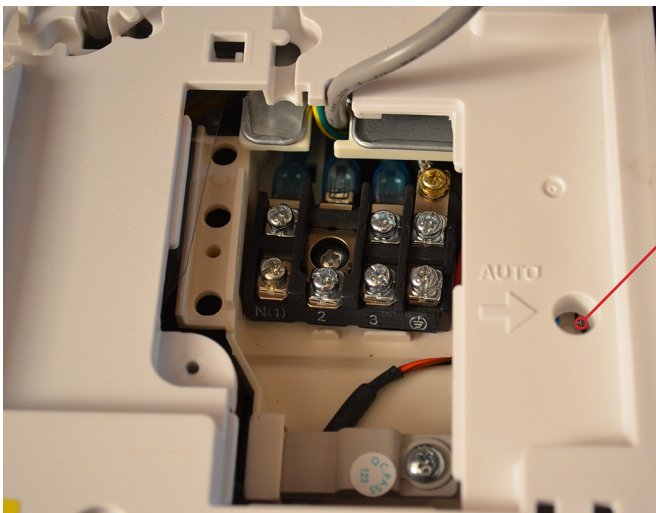

Emergency Operation:

When the remote controller is lost or damaged, please use the auto switch on the indoor unit.

Press the AUTO/STOP button to enter AUTO mode.

Press the AUTO/STOP button again to turn the unit off.

Electrical Schematics

Electrical Legend

● Indoor Unit

Symbol	Color symbol	Symbol	Color symbol	Symbol	Part name
BU	BLUE	BN	BROWN	\oplus	PROTECTIVE EARTH
YE	YELLOW	GN	GREEN	/	/
RD	RED	BK	BLACK	/	/
YEGN	YELLOW GREEN	/	/	/	/

● Outdoor Unit

Symbol	Part name	Symbol	Color symbol	Symbol	Color symbol
C1	CBB61	BN	BROWN	WH	WHITE
C2	CBB65	BU	BLUE	YE	YELLOW
SAT	OVERLOAD	BK	BLACK	RD	RED
COMP	COMPRESSOR	OG	ORANGE	YEGN	YELLOW GREEN
\oplus	PROTECTIVE EARTH	WH	WHITE	/	/

These circuit diagrams are subject to change without notice, please refer to the one supplied with the unit.

● Indoor Unit

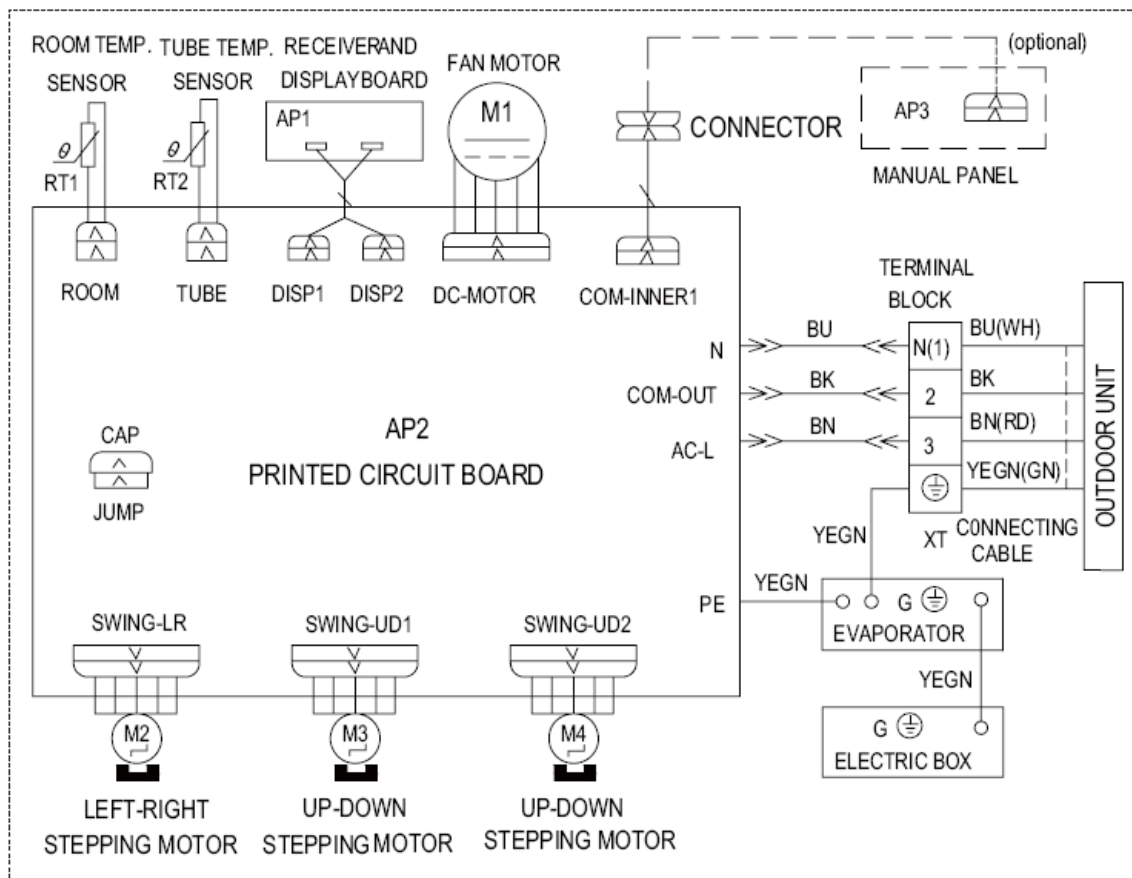

Electrical Schematics

09/12K

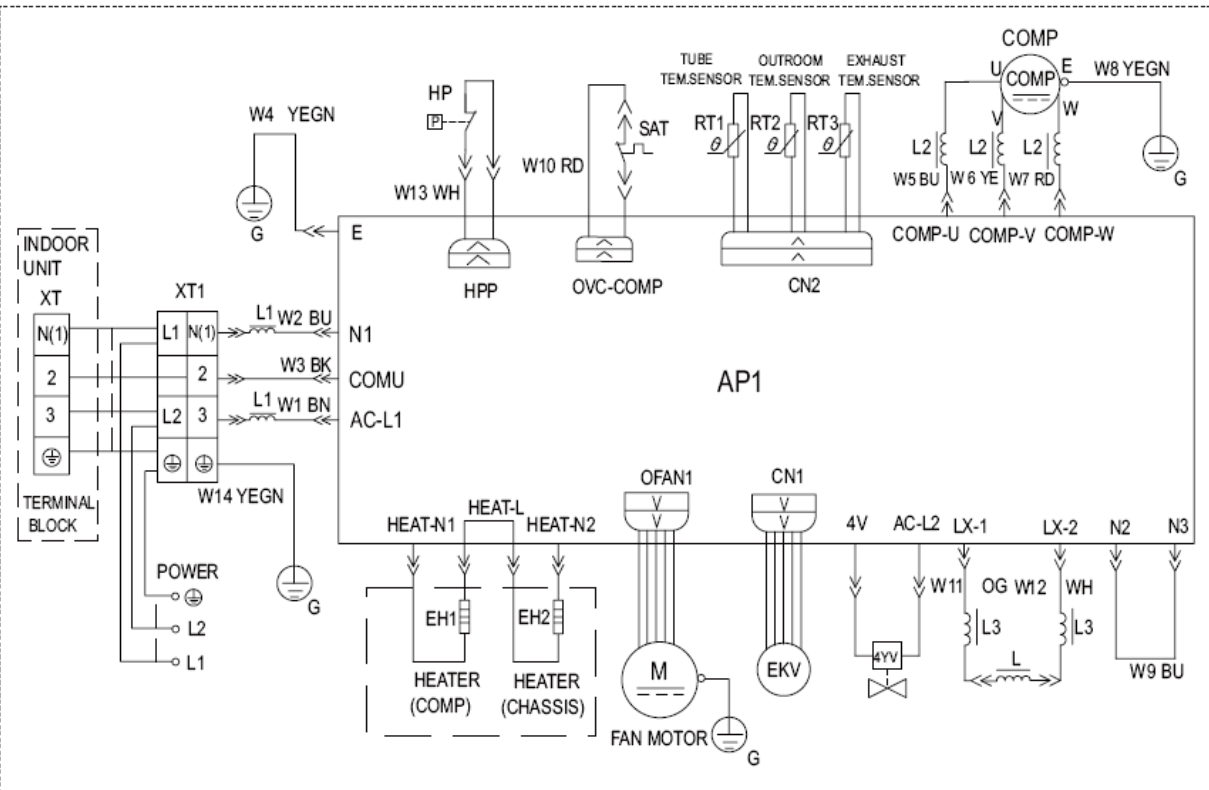

18K

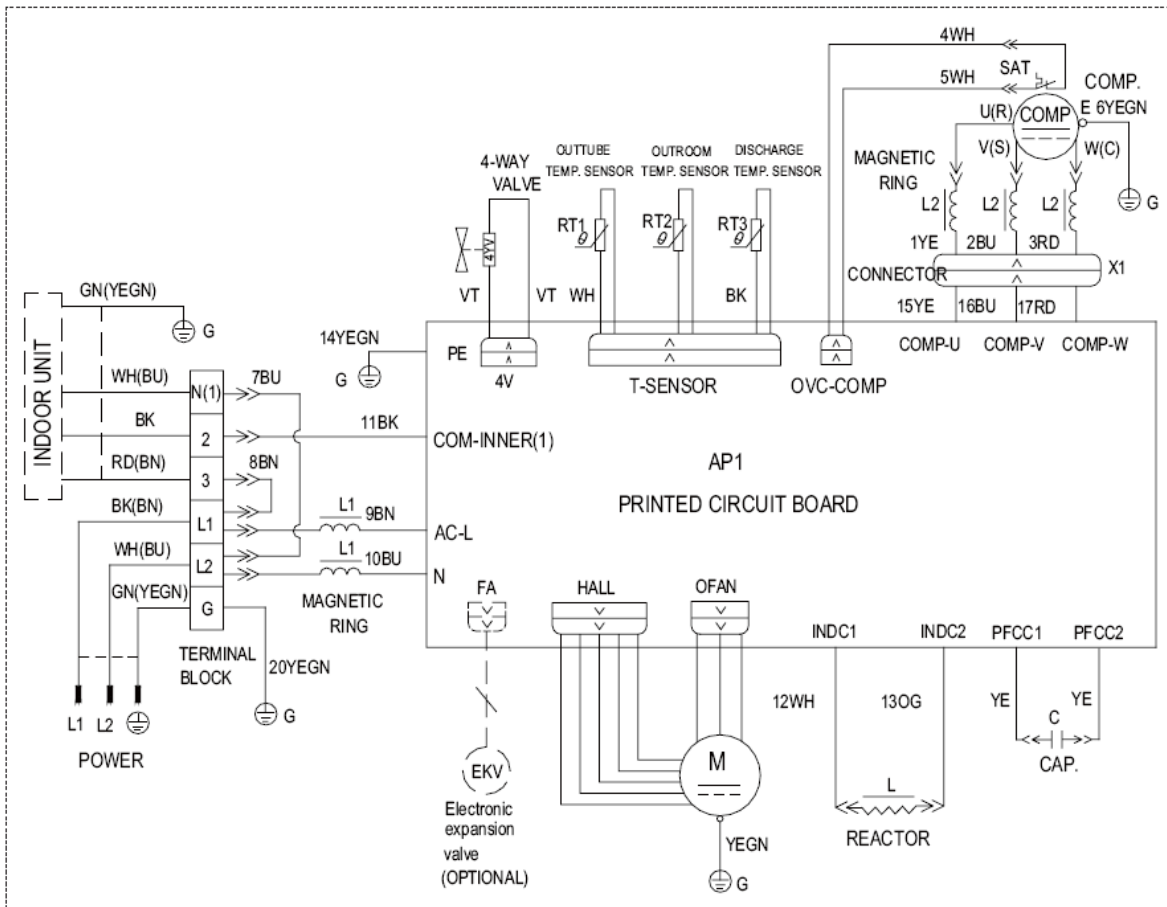

Electrical Schematics

24K

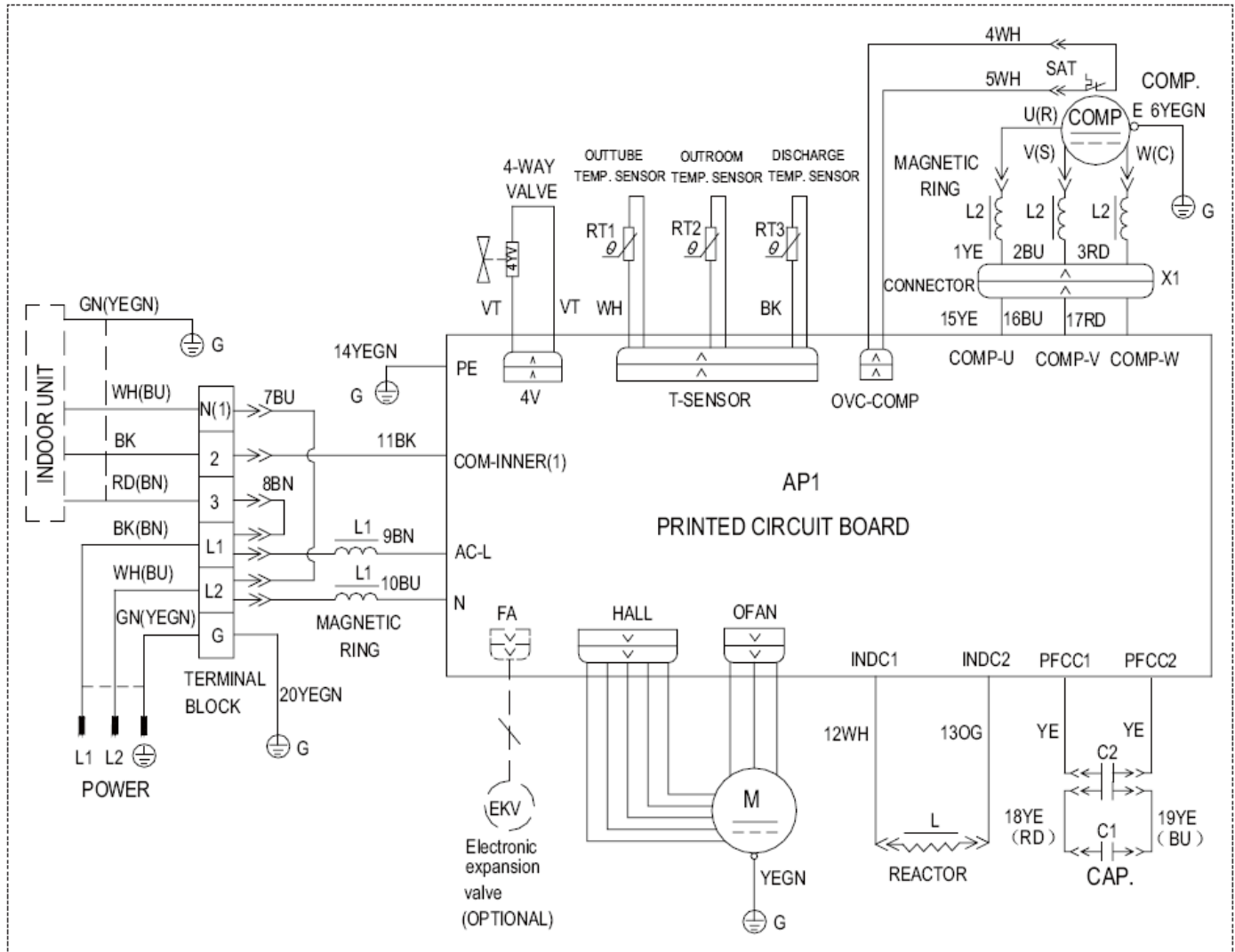

These circuit diagrams are subject to change without notice, please refer to the one supplied with the unit.

Printed Circuit Boards

Indoor Unit

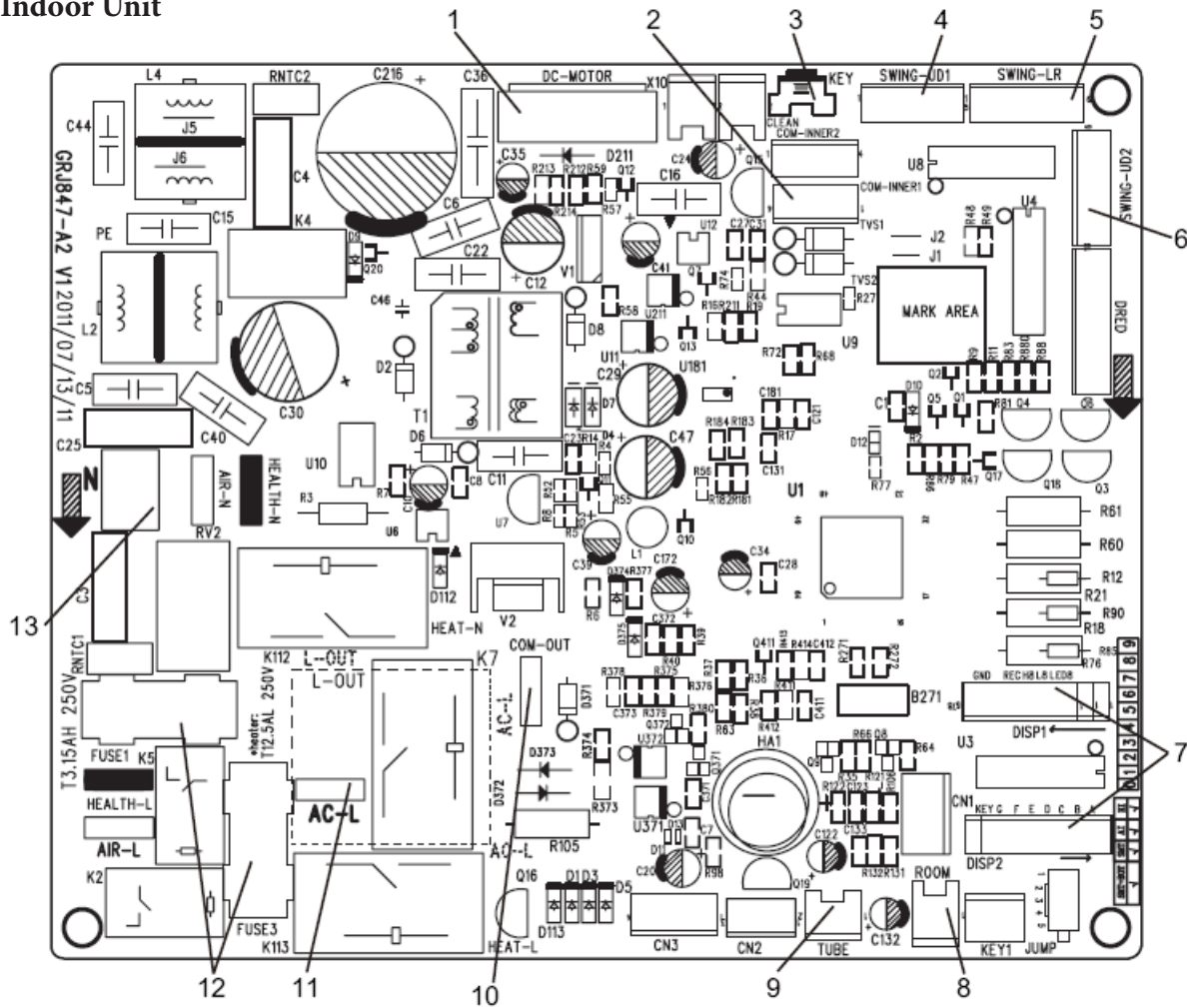

1	DC fan
2	485 communication interface
3	Auto button
4	Interface of small vertical swing
5	Interface of horizontal swing
6	Interface of big vertical swing
7	Interface of display
8	Ambient temp sensor
9	Pipe temp sensor
10	Communication interface of indoor unit
11	Interface of live wire
12	Protective tube
13	Interface of neutral wire

These circuit diagrams are subject to change without notice, please refer to the one supplied with the unit.

Printed Circuit Boards

Outdoor Unit

09/12K

• TOP VIEW

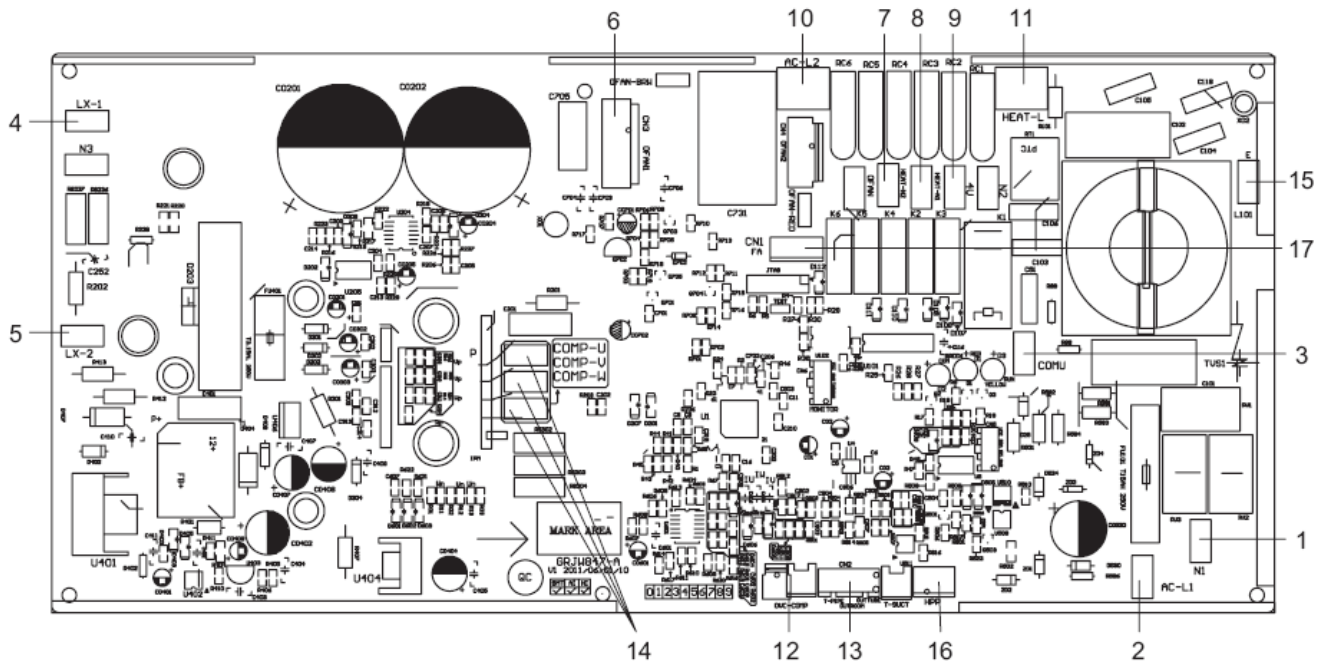

1	Input of neutral wire of power	4	Interface 1 of electric reactor	7	Neutral wire of electric heater of chassis	10	Live wire of 4-way valve	13	Temp sensor
2	Input of live wire of power	5	Interface 2 of electric reactor	8	Neutral wire of electric heater of compressor	11	Live wire of electric heater	14	U,V,W three phases of compressor
3	Communication interface	6	Interface of fan	9	Neutral wire of 4-way valve	12	Input of overload	15	Input of ground wire of power
						16	pressure switch input	17	Electron expansion valve

These circuit diagrams are subject to change without notice, please refer to the one supplied with the unit.

Printed Circuit Boards

Outdoor Unit

18K

• TOP VIEW

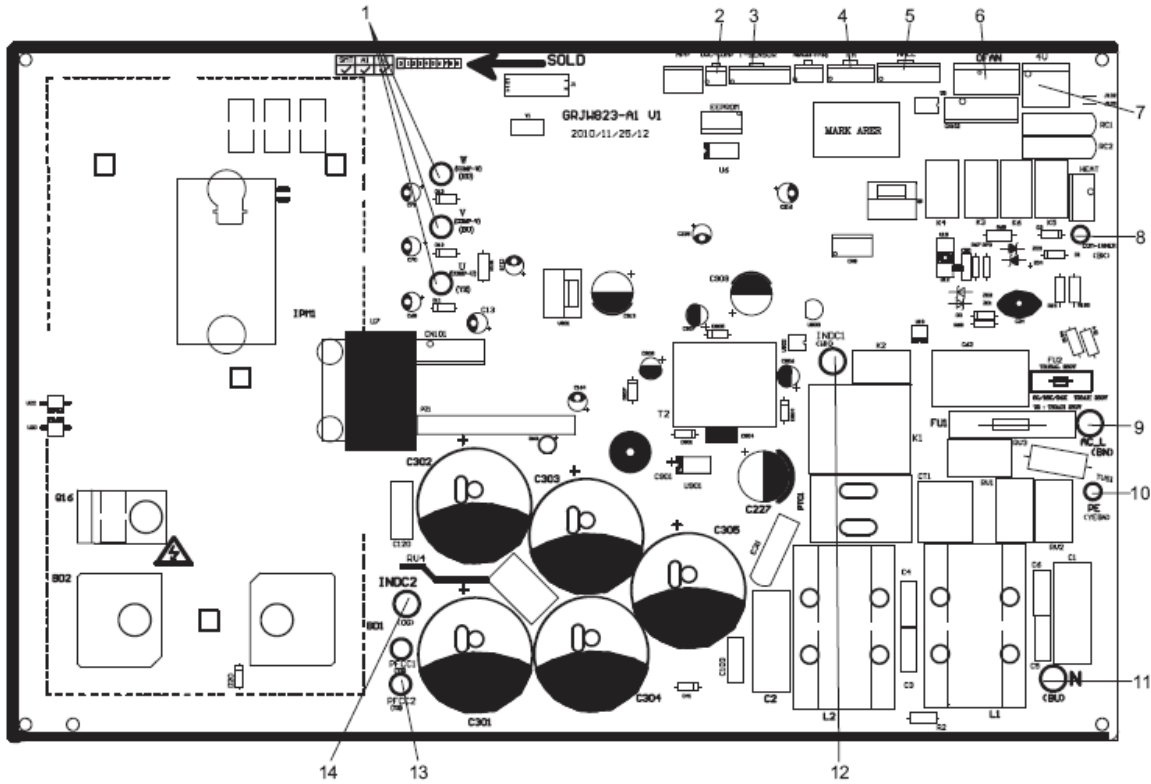

1	Compressor interface	2	Compressor overload protector	3	Temperature sensor	4	Electric expansion valve
5	Fan HALL interface	6	Outdoor fan	7	4-way valve	8	Communication interface with indoor unit
9	Live wire	10	Earthing wire	11	Neutral wire	12	Reactor interface 1
13	PFC capacitor interface 1	14	Reactor interface 2				

These circuit diagrams are subject to change without notice, please refer to the one supplied with the unit.

Printed Circuit Boards

Outdoor Unit

24K

• TOP VIEW

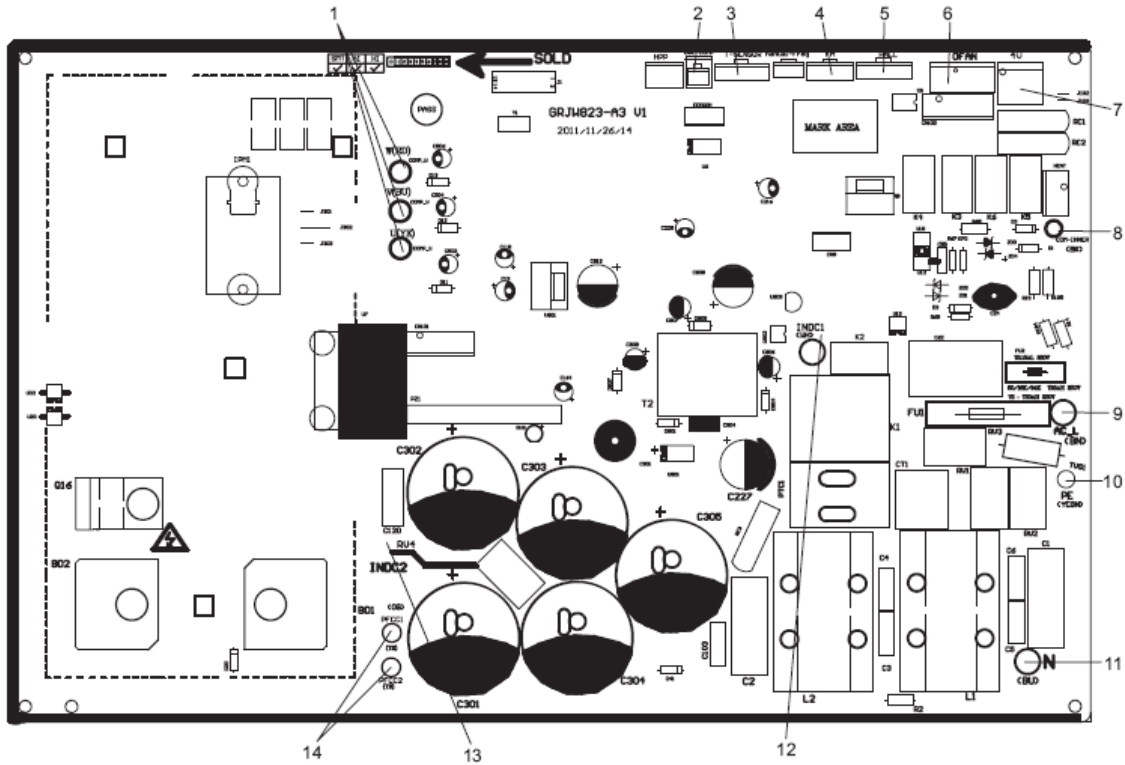

No.	Name	No.	Name	No.	Name	No.	Name
1	Connecting wire of compressor	5	HALL terminal	9	Live wire of power supply	13	Wire 2 of electric reactor
2	Interface of overload of compressor	6	Interface of outdoor fan	10	Ground wire	14	Wire of PFC capacitor
3	Terminal of temp sensor	7	Interface of 4-way valve	11	Neutral wire of power supply		
4	Terminal of electronic expansion valve	8	Communication wire to indoor unit	12	Wire 1 of electric reactor		

These circuit diagrams are subject to change without notice, please refer to the one supplied with the unit.

Troubleshooting Outdoor Components

EEV Troubleshooting

Cooling Mode

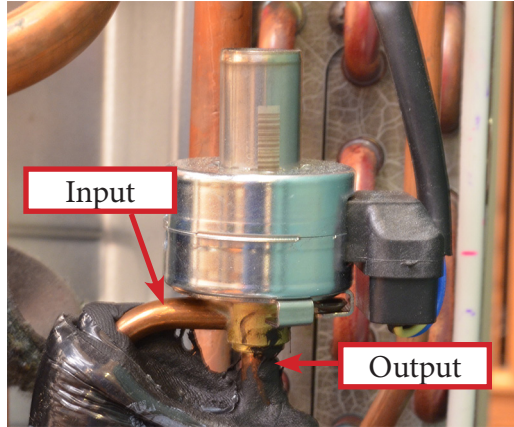

To check the operation of the EEV Valve in cooling mode, using a digital thermometer record the temperature of the input line and the output line of the valve as indicated in the picture above. With the compressor running, the input side of the valve should have a higher reading than the output side indicating that the valve is metering. If the temperature readings are the same, the valve is fully open and the valve is not metering. Since the pressures and frequency are controlled by the G10 technology of the outdoor circuit board, there are no pressure checks that can be made.

Heating Mode

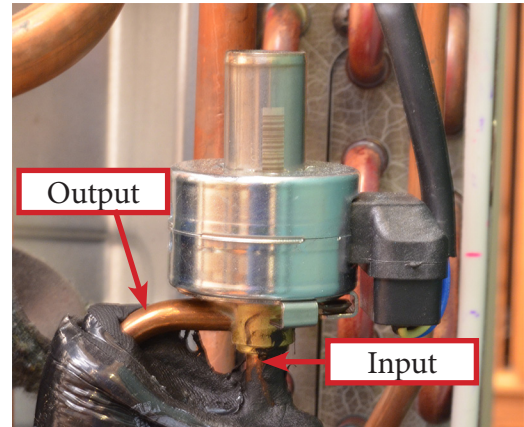

To check the operation of the EEV Valve in heating mode, using a digital thermometer record the temperature of the input line and the output line of the valve as indicated in the picture above. With the compressor running, the input side of the valve should have a higher reading than the output side indicating that the valve is metering. If the temperature readings are the same, the valve is fully open and the valve is not metering. Since the pressures and frequency are controlled by the G10 technology of the outdoor circuit board, there are no pressure checks that can be made.

Resistance readings of EEV valve with wire plug disconnected from circuit board. Power to unit should be off when making resistance readings. Readings below are approximate values and may vary slightly with different outdoor models.

EEV Ω	Orange	Red	Yellow	Black	Blue
Orange		94.6 Ω	94.8 Ω	94.4 Ω	47.0 Ω
Red			94.7 Ω	94.4 Ω	47.5 Ω
Yellow				94.6 Ω	47.7 Ω
Black					47.4 Ω
Blue					

Troubleshooting Outdoor Components

4-Way Valve Troubleshooting

Cooling Mode

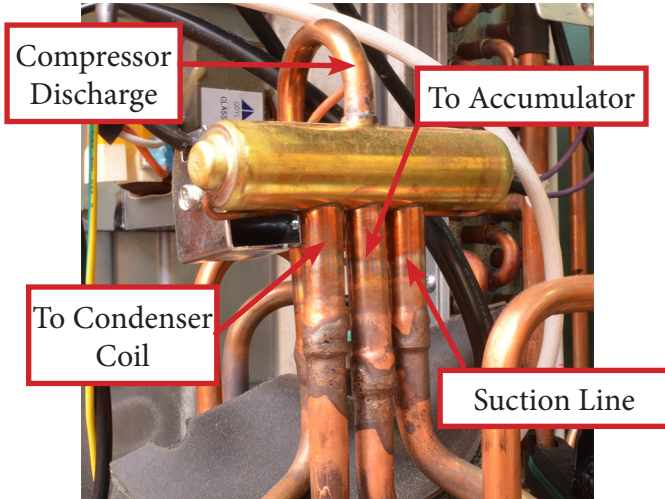

Checking the 4-way valve in cooling mode requires the measurement of 4 readings. First record the temperature of the compressor discharge tubing, secondly record the temperature of the tubing going to the condenser. There should be no more than a 10 degrees difference between the two readings.

The next set of readings will require recording the temperature of the tubing going to the suction line and the temperature of the tubing going to the accumulator. Again, if there should be less than 10 degrees difference between these readings.

A temperature reading higher than 10 degrees may indicate a leaky valve (not fully shifter) or a blockage in the valve.

4-Way valve solenoid resistance check:

Be sure all power is off to the unit. Remove the plug connecting the 4-way valve to the circuit board. Check the resistance with an ohmmeter. The reading should indicate 1.8k Ω . If the reading is infinite, replace the solenoid coil.

Heating Mode

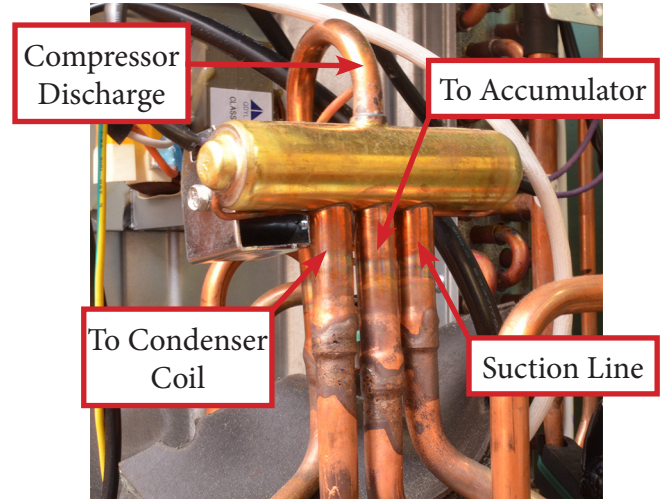

Checking the 4-way valve in heating mode requires the measurement of 4 readings. First record the temperature of the compressor discharge tubing, secondly record the temperature of the suction line tube. There should be no more than a 10 degrees difference between the two readings.

The next set of readings will require recording the temperature of the tubing going to the condenser coil and the temperature of the tubing going to the accumulator. Again, if there should be less than 10 degrees difference between these readings.

A temperature reading higher than 10 degrees may indicate a leaky valve (not fully shifter) or a blockage in the valve.

Troubleshooting Outdoor Components

Temperature Sensor Check

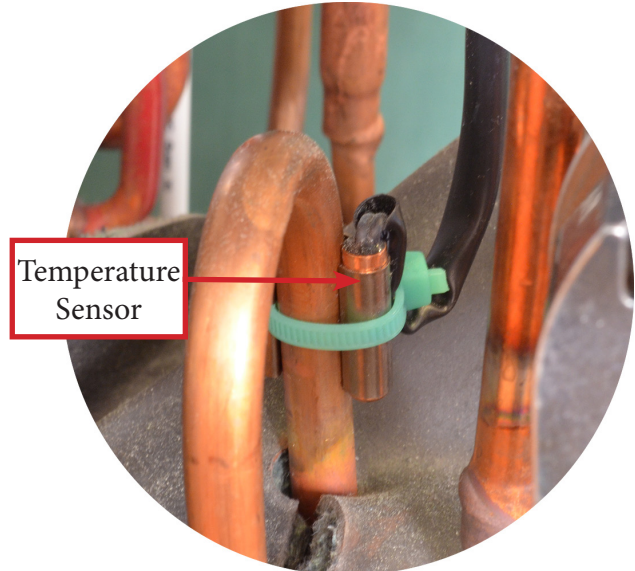

Using a glass of ice water, place the sensor into the glass with a digital thermometer. Wait a few minutes for the reading to stabilize. Compare the readings to the sensor tables in Appendix "A", if the readings are not comparable, replace the sensor. When replacing the sensor, be sure to fasten the sensor securely if it is attached to a tube.

Temp (°C)	Temp (°F)	Resistance (kΩ)		Temp (°C)	Temp (°F)	Resistance (kΩ)		Temp (°C)	Temp (°F)	Resistance (kΩ)
0	32.0	49.02		52	125.6	4.986		104	219.2	0.898
1	33.8	46.6		53	127.4	4.802		105	221.0	0.873
2	35.6	44.31		54	129.2	4.625		106	222.8	0.848
3	37.4	42.14		55	131.0	4.456		107	224.6	0.825
4	39.2	40.09		56	132.8	4.294		108	226.4	0.802
5	41.0	38.15		57	134.6	4.139		109	228.2	0.779
6	42.8	36.32		58	136.4	3.99		110	230.0	0.758
7	44.6	34.58		59	138.2	3.848		111	231.8	0.737
8	46.4	32.94		60	140.0	3.711		112	233.6	0.717
9	48.2	31.38		61	141.8	3.579		113	235.4	0.697

Troubleshooting Outdoor Components

Compressor Windings

Compressor Windings
Red, Yellow & Blue Wires

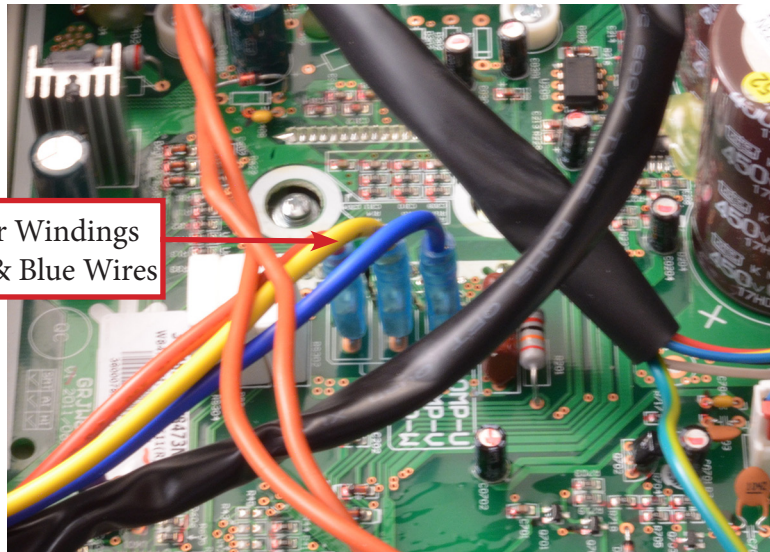

Compressor Winding Resistance Check:

Unplug the wire spade connectors from the circuit board. The spade terminals have a small clip to press for removal. Press this clip slightly inward, then lift straight up on terminal. The wires red to yellow, yellow to blue & red to blue should have readings from 2 - 4 ohms. There should be no reading from any wire to chassis ground. If the readings between the windings differ greatly, the windings are bad. If there is a reading from any wire to the chassis, there is leakage in the windings.

Outdoor Fan Motor

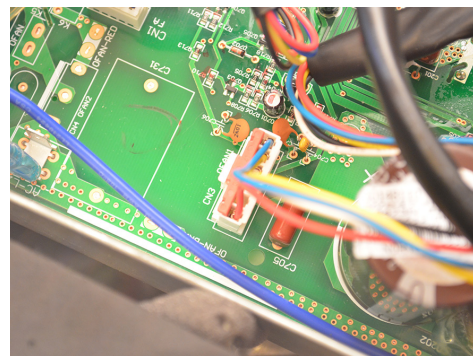
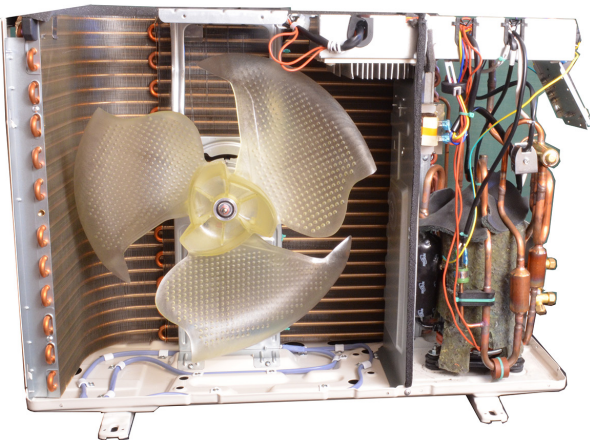

Outdoor Motor Winding Resistance Check:

The outdoor motor is an ECM motor, so resistance checks are more difficult to read. Polarity of your meter will make a difference in the readings. It is advisable if in doubt about the fan motor, remove the plug of the existing motor with the power disconnected, then plug a new motor into the circuit board before mounting the motor. Isolate and secure the new motor, then safely turn the unit on and check operation. If the motor start correctly, change the motor, otherwise the circuit board should be replaced.

Troubleshooting Outdoor Components

Base Pan Heater Check

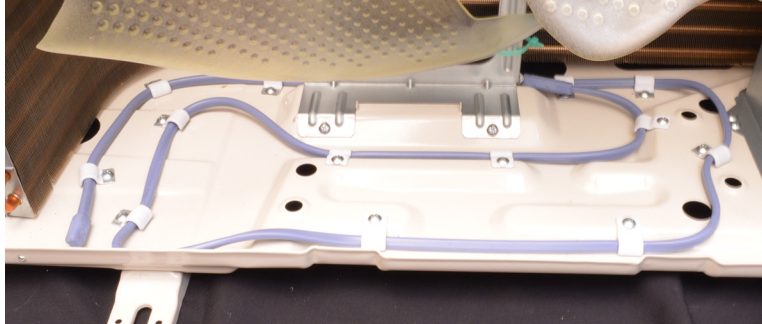

Base Pan Heater Resistance Check:

Unplug the wire connector from the circuit board. The resistance should read approximately 740 ohms. There should be no reading from either wire to ground. If readings vary from these measurements, replace the heater.

Compressor Crankcase Heater Check

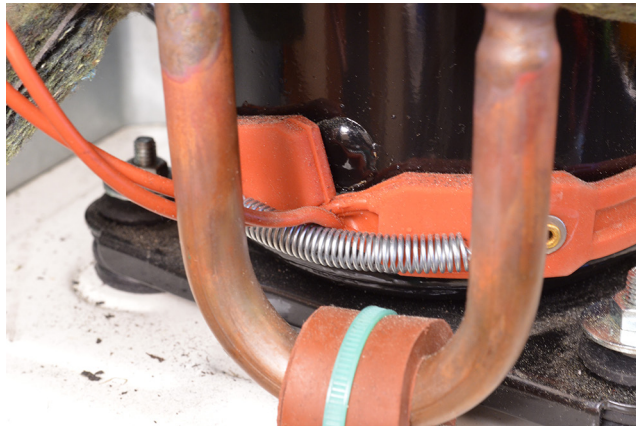

Compressor Crankcase Heater Resistance Check:

Unplug the wire connector from the circuit board. The resistance should read approximately 2.15K ohms. There should be no reading from either wire to ground. If readings vary from these measurements, replace the heater.

Troubleshooting Outdoor Components

Reactor

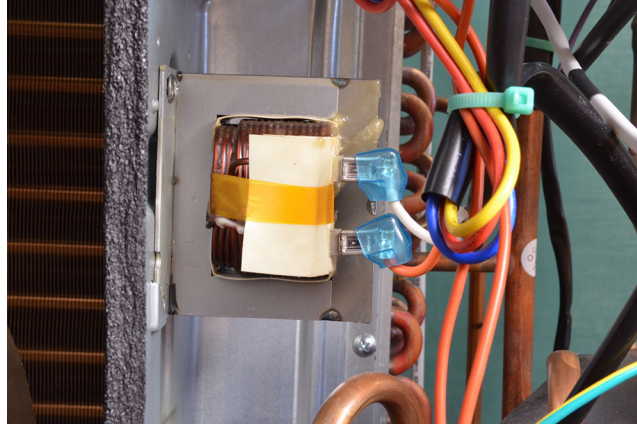

Reactor Resistance Check:

The line reactor helps to smooth the inrush current, reduce harmonics and noise, and buffers the system, protecting the electronics from transient voltage noise. The resistance between the coils will be very low, approximately .3 ohms and should not have any resistance to ground. You should disconnect the wires from the reactor before taking any readings.

Fault Displays

Outdoor Unit Indicator Display

Yellow indicator blinks once	→	Compressor starts (normal)
Yellow indicator blinks twice	→	Defrosting (normal display of indoor unit)
Yellow indicator blinks for 3 times	→	Anti-freezing protection (normal display of indoor unit)
Yellow indicator blinks for 4 times	→	IPM protection
Yellow indicator blinks for 5 times	→	Overcurrent protection
Yellow indicator blinks for 6 times	→	Overload protection
Yellow indicator blinks for 7 times	→	Exhaust protection
Yellow indicator blinks for 8 times	→	Overload protection of compressor
Red indicator blinks once	→	Cooling (dehumidify or heating current dropped frequency current)
Red indicator blinks twice	→	Exhaust temp dropped frequency temp
Red indicator blinks for 3 times	→	Tube temp dropped frequency temp
Red indicator blinks for 4 times	→	Tube dropped frequency temp
Red indicator blinks for 5 times	→	Outdoor condenser temp sensor malfunction
Red indicator blinks for 6 times	→	Outdoor ambient temp sensor malfunction
Red indicator blinks for 7 times	→	Outdoor exhaust temp sensor malfunction
Red indicator blinks for 8 times	→	Starting at temp does not reach
Green indicator does not blink	→	Communication is abnormal

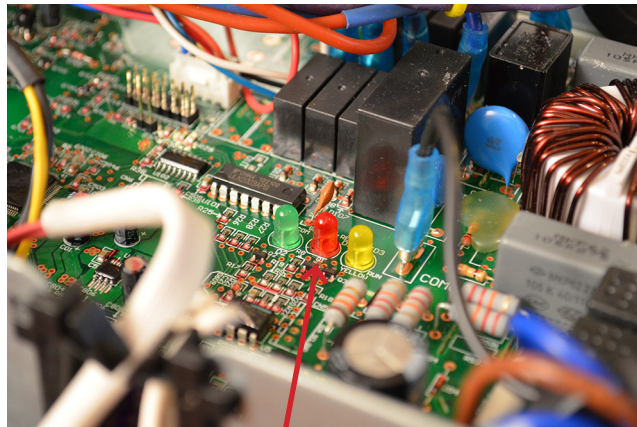

Fault Indicator Lights
Outdoor Unit

Fault and Status Display Table 9,000/12,000 Systems

#	Malfunction Name	Malfunction Type	Indoor Display	LED Lamp for Operation	LED Lamp for Cooling	LED Lamp for Heating	Yellow LED Lamp	Red LED Lamp
1	Malfunction of Circuit for zero cross detection	Malfunction of Hardware	U8	Blinks for 17 times				
2	Malfunction protection for jumper cap		C5	Blinks for 15 times				
3	No feedback from indoor motor		H6	Blinks for 11 times				
4	Indoor ambient temp sensor has open or short circuit		F1		Blinks once			
5	Indoor evaporator temp sensor has open or short circuit		F2		Blinks twice			
6	Liquid valve temp sensor has open or short circuit		b5		Blinks for 19 times			
7	Gas valve temp sensor has open or short circuit		b7		Blinks for 22 times			
8	Module temp sensor has open or short circuit		P7				Blinks for 18 times	
9	Outdoor ambient temp sensor has open or short circuit		F3		Blinks for 3 times			Blinks for 6 times
10	Outdoor inlet pipe temp sensor of condenser has open or circuit (for commercial use)		A5					
11	Outdoor middle pipe temp sensor of condenser has open or short circuit		F4		Blinks for 4 times			Blinks for 5 times
12	Outdoor outlet pipe of condenser has open or short circuit (for commercial use)		A7					
13	Outdoor discharge temp sensor has open or short circuit		F5		Blinks for 5 times			Blinks for 7 times
14	Communication malfunction of indoor and outdoor units		E6	Blinks for 6 times				
15	Malfunction of circuit for detecting phase current of compressor		U1				Blinks for 12 times	
16	Demagnetization protection of compressor		HE				Blinks for 14 times	
17	Malfunction of voltage drop of DC bus bar		U3				Blinks for 20 times	
18	Module temperature protection		P8				Blinks for 19 times	Blinks for 10 times
19	Lack of refrigerant or block protection for the system (not applicable to residential air conditioner)		F0		Blinks for 10 times			
20	Malfunction of charging for capacitor		PU				Blinks for 17 times	

Fault and Status Display Table 9,000/12,000 Systems

21	High pressure protection for the system	Malfunction of Hardware	E1	Blinks once				
22	Low pressure protection for the system (reserved)		E3	Blinks for 3 times				
23	Lock of compressor (for commercial air conditioner)		LE					
24	Reset of drive module (for commercial air conditioner)		P0					
25	Overspeed (for commercial air conditioner)		LF					
26	Malfunction of		PF					
27	AC contactor protection (for commercial air conditioner)		P9					
28	Temperature drift protection (for commercial air conditioner)		PE					
29	Sensor connection protection (for commercial air conditioner)		Pd					
30	Communication malfunction for drive board (for commercial air conditioner)		P6	Blinks for 16 times				
31	Thermal overload protection for compressor		H3			Blinks for 3 times	Blinks for 8 times	
32	Non-match between indoor and outdoor units		LP				Blinks for 16 times	
33	Malfunction of memory chip		EE			Blinks for 15 times		
34	Wrong connection of communication wire or malfunction of expansion valve (free match)		dn					
35	Malfunction of current detection for the complete unit		U5		Blinks for 13 times			
36	Wrong connection of communication wire or status of detecting malfunction of expansion valve (free match)		dd					
37	Mode conflict		Fo	Blinks once	Blinks once			
38	Refrigerant reclaiming mode		H1			Blinks once	Blinks twice	
39	Oil return under defrosting or heating		P1					
40	Nominal cooling or heating (capacity test code)		P2					
41	Max. cooling or heating (capacity test code)		P3					
42	Middle cooling or heating (capacity test code)		P0					
43	Min. Cooling or heating (capacity test code)							

Fault and Status Display Table 9,000/12,000 Systems

44	Failure of startup of compressor	Display is controlled by remote control	Lc			Blinks for 11 times		
45	High discharge temperature protection of compressor		E4	Blinks for 4 times			Blinks for 7 times	
46	Overload protection		E8	Blinks for 8 times			Blinks for 6 times	
47	Overcurrent protection for the complete unit		E5	Blinks for 5 times			Blinks for 5 times	
48	Overcurrent protection for the complete unit		P5			Blinks for 15 times		
49	Desynchronizing of compressor		H7			Blinks for 7 times		
50	Lack/reverse phase protection of		Ld					
51	Module current protection (IPM protection)		H5			Blinks for 5 times	Blinks for 4 times	
52	Low voltage protection for DC bus bar		PL			Blinks for 21 times	Blinks for 12 times	
53	High voltage protection for DC bus bar		PH		Blinks for 11 times		Blinks for 13 times	
54	PFC protection		HC			Blinks for 6 times	Blinks for 14 times	
55	High power protection (not for outdoor)		L9	Blinks for 20 times			Blinks for 9 times	
56	Abnormal reversing of 4-way valve		U7		Blinks for 20 times			
57	Frequency limit/decrease for current protection of the complete unit		F8		Blinks for 8 times			Blinks once
58	Frequency limit/decrease for current protection of the module (phase current)		En					
59	Frequency limit/decrease for high discharge temperature		F9		Blinks for 9 times			Blinks twice
60	Frequency limit/decrease for freeze protection		FH		Blinks twice	Blinks twice		Blinks for 4 times

Fault and Status Display Table 9,000/12,000 Systems

61	Frequency limit/decrease for overload	Display is controlled by remote control	F6		Blinks for 6 times			Blinks for 3 times
62	Frequency limit/decrease for module temperature protection		EU		Blinks for 6 times	Blinks for 6 times		Blinks for 11 times
63	Oil return in cooling		F7		Blinks for 7 times			
64	Cold air prevention		E9	Blinks for 9 times				
65	Freeze protection		E2	Blinks twice			Blinks for 3 times	
66	Reading malfunction of EE-PROM						Blinks for 11 times	
67	Reaching temperature for turning on the unit							Blinks for 8 times
68	Frequency limit (power)							Blinks for 13 times
69	Malfunction of outdoor fan							Blinks for 14 times

Troubleshooting 18,000/24,000 btuh Units

#	Malfunction Name	Indoor Unit Display Method		Outdoor Unit Display Method (repeated every 5 seconds)				A/C Status	Possible Causes
		Indoor Display	Operation Indicator	□ = Off	■ = Illuminated	★ = Blink			
1	High pressure protection of system	E1	OFF 3S and blink once	□	★	★	★	During cooling and drying operation, except indoor fan operates, all loads stop operation. During heating operation, the complete unit stops	Possible reasons: 1. Refrigerant was superabundant; 2. Poor heat exchange (including filth blockage of heat exchanger and bad radiating environment); Ambient temperature is too high
2	Anti-freezing protection	E2	OFF 3S and blink twice	■	□	■	□	During cooling and drying operation, compressor and outdoor fan stop while indoor fan operates	1. Poor air-return in indoor unit; 2. Fan speed is abnormal; 3. Evaporator is dirty
3	High discharge temperature protection of compressor	E4	Off 3S and blink 4 times	■	□	■	★	During cooling and drying operation, compressor and outdoor fan stop while indoor fan operates. During heating operation, all loads stop.	Please refer to the malfunction analysis (discharge protection, overload).
4	Overcurrent protection	E5	Off 3S and blink 5 times	□	■	★	□	During cooling and drying operation, compressor and outdoor fan stop while indoor fan operates. During heating operation, all loads stop.	1. Supply voltage is unstable; 2. Supply voltage is too low and load is too high; 3. Evaporator is dirty.
5	Communication Malfunction	E6	Off 3S and blink 6 times	□	□	□	★	During cooling operation, compressor stops while indoor fan motor operates. During heating operation, the complete unit stops.	Refer to corresponding malfunction analysis
6	High temperature resistant protection	E8	Off 3S and blink 8 times	■	□	■	■	During cooling operation, compressor stops while indoor fan motor operates. During heating operation, the complete unit stops.	Refer to the malfunction analysis (overload, high temperature resistant).
7	Internal motor (fan motor) do not operate	H6	Off 3S and blink 11 times					Internal fan motor, external fan motor, compressor and electric heater stop operation, guide louver stops at present location	1. Bad contact of DC motor feedback terminal; 2. Bad contact of DC motor control end; 3. Fan motor is stalling; 4. Motor malfunction; 5. Malfunction of mainboard rev detecting circuit
8	Malfunction protection of jumper cap	C5	Off 3S and blink 15 times					Wireless remote receiver and button are effective, but can not dispose the related command	1. No jumper cap insert on mainboard; 2. Incorrect insert of jumper cap; 3. Jumper cap damaged; 4. Abnormal detecting circuit of mainboard.

Troubleshooting 18,000/24,000 btuh Units, cont.

#	Malfunction Name	Indoor Unit Display Method		Outdoor Unit Display Method (repeated every 5 seconds)				A/C Status	Possible Causes
		Indoor Display	Cool Indicator	<input type="checkbox"/> = Off	<input checked="" type="checkbox"/> = Illuminated	★ = Blink			
9	Indoor ambient temperature sensor is open/short circuited	F1	Off 3S and blink once					During cooling and drying operation, indoor unit operates while other loads will stop, during heating operation, the complete unit will stop operation.	1. Loosening or bad contact of indoor ambient temp sensor and mainboard terminal; 2. Components in mainboard fell down leads short circuit; 3. Indoor ambient temp sensor damaged (check with sensor resistance value chart); 4. Mainboard damaged.
10	Overcurrent protection of phase current for compressor	P5	Off 3S and blink 15 times	<input type="checkbox"/>	★	<input type="checkbox"/>	<input type="checkbox"/>	During cooling and drying operation, indoor unit operates while other loads will stop, during heating operation, the complete unit will stop operation.	Refer to the malfunction analysis (IPM protection, loss of synchronism protection and overcurrent protection of phase current for compressor).
11	Indoor evaporator temperature sensor is open/short circuited	F2	Off 3S and blink twice					AC stops operation once reaches the setting temperature. Cooling, drying; internal fan motor stops operation while other loads stop operation; heating: AC stop operation	1. Loosening or bad contact of indoor evaporator temp sensor and mainboard terminal; 2. Components on the mainboard fall; 3. Indoor evaporator temp sensor damaged; 4. Mainboard damaged.
12	Outdoor ambient temperature sensor is open/short circuited	F3	Off 3S and blink 3 times	<input type="checkbox"/>	<input type="checkbox"/>	★	<input checked="" type="checkbox"/>	During cooling and drying operating, compressor stops while indoor fan operates; During heating operation, the complete unit will stop operation.	Outdoor temperature sensor hasn't been connected well or is damaged. Please check it by referring to the resistance table for temperature sensor
13	Outdoor condenser temperature sensor is open/short circuited	F4	Off 3S and blink 4 times	<input type="checkbox"/>	<input type="checkbox"/>	★	<input type="checkbox"/>	During cooling and drying operation, compressor stops while indoor fan will operate; During heating operation, the complete unit will stop operation.	Outdoor temperature sensor hasn't been connected well or is damaged. Please check it by referring to the resistance table for temperature sensor
14	Outdoor discharge temperature sensor is open/short circuited	F5	Off 3S and blink 5 times		★	★	★	During cooling and drying operation, compressor will stop after operating for about 3 mins, while indoor fan will operate. During heating operation, the complete unit will stop after operating for about 3 mins.	1. Outdoor temperature sensor hasn't been connected well or is damaged. Please check it by referring to the resistance table for temperature sensor; 2. The head of temperature sensor hasn't been inserted into the copper tube.

Troubleshooting 18,000/24,000 btuh Units, cont.

#	Malfunction Name	Indoor Unit Display Method		Outdoor Unit Display Method (repeated every 5 seconds)				A/C Status	Possible Causes
		Indoor Display	Cool Indicator	□ = Off	■ = Illuminated	★ = Blink			
15	Limit/decrease frequency due to overload	F6	Off 3S and blink 6 times	■	□	★	★	All loads operate normally, while operation frequency for compressor is decreased.	Refer to the malfunction analysis (overload, high temperature resistant).
16	Decrease frequency due to overcurrent	F8	Off 3S and blink 8 times	■	■	□	■	All loads operate normally, while operation frequency for compressor is decreased.	The input supply voltage is too low; System pressure is too high and overload
17	Decrease frequency due to high air discharge	F9	Off 3S and blink 9 times	■	■	□	□	All loads operate normally, while operation frequency for compressor is decreased.	Overload or temperature is too high; Refrigerant is insufficient; Malfunction of electric expansion valve (EKV)
18	Voltage for DC bus-bar is too high	PH	Off 3S and blink 11 times	□	■	□		During cooling and drying operation, compressor will stop while indoor fan will operate. During heating operation, the complete unit will stop operation.	1. Measure the voltage of position L and N on wiring board (XT), if the voltage is high than 265VAC, turn on the unit after the supply voltage is increased to the normal range; 2. If the AC input is normal, measure the voltage of electrolytic capacitor C on control panel (AP1), if its normal, theres malfunction for the circuit, please replace the control panel (AP1)
19	Malfunction of complete units current detection	U5	Off 3S and blink 13 times	o	n	«	n	During cooling and drying operation, compressor will stop while indoor fan will operate. During heating operation, the complete unit will stop operation.	Theres circuit malfunction on outdoor units control panel AP1, please replace the outdoor units control panel AP1.

Troubleshooting 18,000/24,000 btuh Units, cont.

#	Malfunction Name	Indoor Unit Display Method		Outdoor Unit Display Method (repeated every 5 seconds) □ = Off ■ = Illuminated ★ = Blink				A/C Status	Possible Causes
		Indoor Display	Heating Indicator						
20	Defrosting	H1	Off 3S and blink once					Defrosting will occur in heating mode. Compressor will operate while indoor fan will stop operation	It's the normal state
21	Static dedusting protection	H2	Off 3S and blink twice						
22	Overload protection for compressor	H3	Off 3s and blink 3 times	□	★	★	□	During cooling and drying operation, compressor will stop while indoor fan will operate. During heating operation, the complete unit will stop operation.	1. Wiring terminal OVC-COMP is loosened. In normal state, the resistance for this terminal should be less than 1ohm; 2. Refer to the malfunction analysis (discharge protection, overload)
23	System is abnormal	H4	Off 3s and blink 4 times	■	□	■	■	During cooling and drying operation, compressor will stop while indoor fan will operate. During heating operation, the complete unit will stop operation.	Refer to the malfunction analysis (IPM protection, loss of synchronism protection and overcurrent protection of phase current for compressor).
24	IPM protection	H5	Off 3s and blink 5 times	□	★	□	■	During cooling and drying operation, compressor will stop while indoor fan will operate. During heating operation, the complete unit will stop operation.	Refer to the malfunction analysis (IPM protection, loss of synchronism protection and overcurrent protection of phase current for compressor).
25	PFC protection	HC	Off 3s and blink 6 times	□	■	★	★	During cooling and drying operation, compressor will stop while indoor fan will operate. During heating operation, the complete unit will stop operation.	Refer to the malfunction analysis
26	Desynchronizing of compressor	H7	Off 3s and blink 7 times	□	★	■	★	During cooling and drying operation, compressor will stop while indoor fan will operate. During heating operation, the complete unit will stop operation.	Refer to the malfunction analysis (IPM protection, loss of synchronism protection and overcurrent protection of phase current for compressor).

Troubleshooting 18,000/24,000 btuh Units, cont.

#	Malfunction Name	Indoor Unit Display Method		Outdoor Unit Display Method (repeated every 5 seconds)				A/C Status	Possible Causes
		Indoor Display	Heating Indicator	□ = Off	■ = Illuminated	★ = Blink			
27	Decrease frequency due to high temperature resistant during heating operation	H0	Off 3s and blink 10 times	■	□	★	★	All loads operate normally, while operation frequency for compressor is decreased.	Refer to malfunction analysis (overload, high temperature resistant)
28	Failure startup	LC	Off 3s and blink 11 times	□	★	□	★	During cooling and drying operation, compressor will stop while indoor fan will operate. During heating operation, the complete unit will stop operation.	Refer to malfunction analysis
29	Malfunction of phase current detection circuit for compressor	U1	Off 3s and blink 13 times	□	★	■	□	During cooling and drying operation, compressor will stop while indoor fan will operate. During heating operation, the complete unit will stop operation.	Replace outdoor control panel AP1
30	EEPROM malfunction	EE	Off 3s and blink 15 times	□	□	□	■	During cooling and drying operation, compressor will stop while indoor fan will operate. During heating operation, the complete unit will stop operation.	Replace outdoor control panel AP1
31	Charging malfunction of capacitor	PU	Off 3s and blink 17 times	□	■	□	■	During cooling and drying operation, compressor will stop while indoor fan will operate. During heating operation, the complete unit will stop operation.	Refer to the part three-charging malfunction analysis of capacitor
32	Malfunction of module temperature sensor circuit	P7	Off 3s and blink 18 times	□	□	■	★	During cooling and drying operation, compressor will stop while indoor fan will operate. During heating operation, the complete unit will stop operation.	Replace outdoor control panel AP1
33	Module high temperature protection	P8	Off 3s and blink 19 times	■	□	★	■	During cooling and drying operation, compressor will stop while indoor fan will operate. During heating operation, the complete unit will stop operation.	After the complete unit is de-energized for 20 mins, check whether the thermal grease on the IPM Module of outdoor control panel AP1 is sufficient and whether the radiator is inserted tightly. If its no use, please replace control panel AP1

Troubleshooting 18,000/24,000 btuh Units, cont.

#	Malfunction Name	Indoor Unit Display Method		Outdoor Unit Display Method (repeated every 5 seconds)				A/C Status	Possible Causes
		Indoor Display	Heating Indicator	□ = Off	■ = Illuminated	★ = Blink			
34	Malfunction of voltage dropping for DC bus-bar	U3	Off 3s and blink 20 times	□	■	■	■	During cooling and drying operation, compressor will stop while indoor fan will operate. During heating operation, the complete unit will stop operation.	Supply voltage is unstable
35	Voltage of DC bus-bar is too low	PL	Off 3s and blink 21 times	□	■	■	□	During cooling and drying operation, compressor will stop while indoor fan will operate. During heating operation, the complete unit will stop operation.	1. Measure the voltage of position L and N on wiring board (XT), if the voltage is higher than 150VAC, turn on the unit after the supply voltage is increase to the normal range; 2. If the AC input is normal, measure the voltage of electrolytic capacitor C on control panel (AP1), if its normal, theres malfunction for the circuit, please replace the control panel (AP1)
36	Limit/decrease frequency due to high temperature of module	EU		■	■	■	★	All loads operate normally, while operation frequency for compressor is decreased.	Discharging after the complete unit is de-energized for 20 mins check on whether the thermal grease on IPM Module of outdoor control panel AP1 is sufficient and whether the radiator is inserted tightly. If its no use, please replace control panel AP1.
37	The four-way valve is abnormal	U7		■	□	★	□	If this malfunction occurs during heating operation, the complete unit will stop operation.	1. Supply voltage is lower than AC175V; 2. Wiring terminal 4V is loosened or broken; 3. 4V is damaged, please replace 4V
38	Zero-crossing malfunction of outdoor unit	U9		■	■	★	□	During cooling and drying operation, compressor will stop while indoor fan will operate. During heating operation, the complete unit will stop operation.	Replace outdoor control panel AP1
39	Limit/decrease frequency due to freezing	FH		■	■	■	□	All loads operate normally, while operation frequency for compressor is decreased.	Poor air-return in indoor unit or fan speed is too low

Error Code Diagnostics

C5 Error Code

C5



Jumper Cap Malfunction

Status:

Wireless remote will not send command to indoor unit.

1. No jumper cap inserted on board
2. Jumper cap not fully seated
3. Jumper cap damaged
4. Bad control board

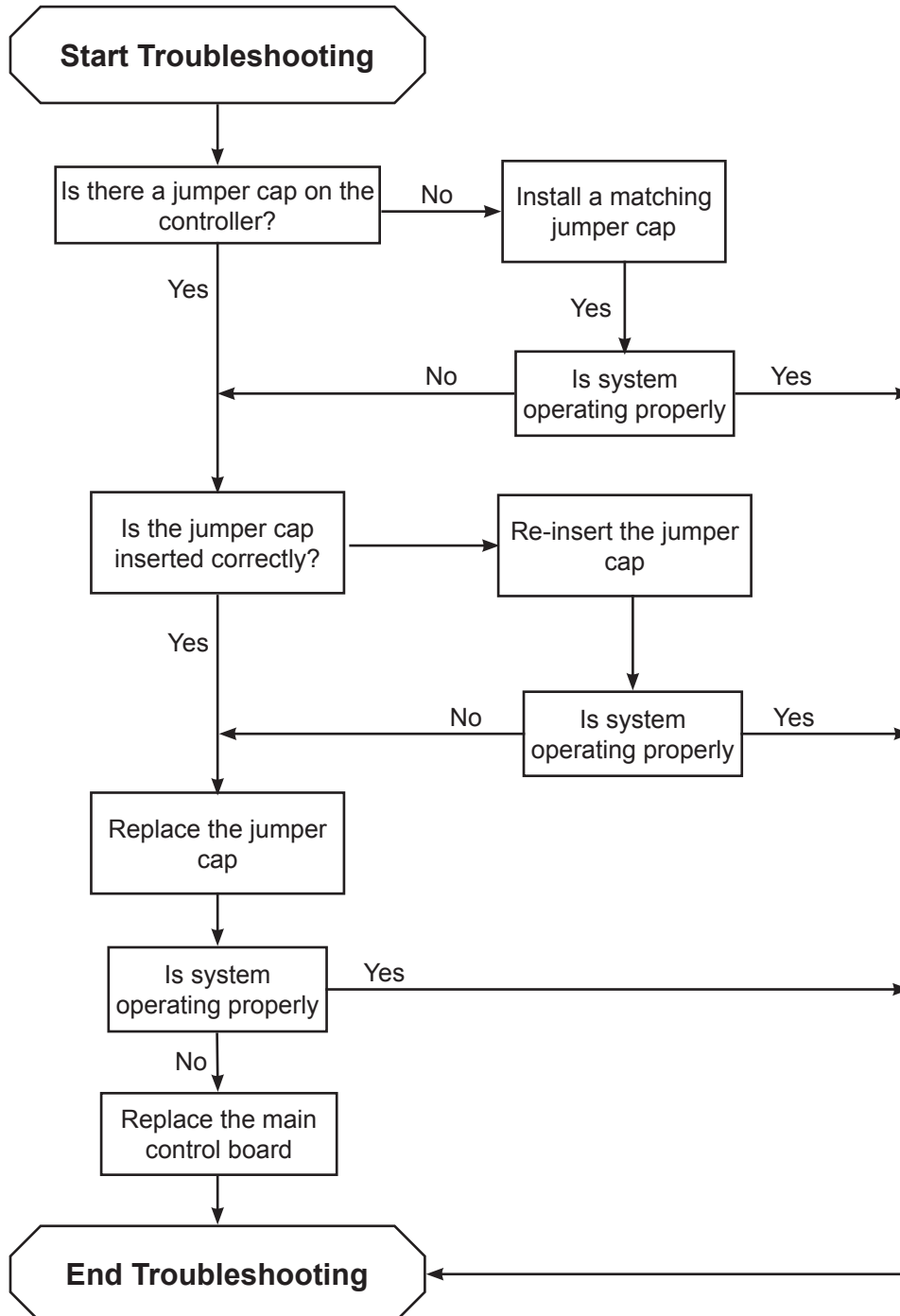

Error Code Diagnostics

EE, EU, FH Error Codes

Fault & Status

Possible Causes

EE



EEProm Malfunction

Status:

During cooling & dehumidifying, indoor unit operates while other functions stop; During heating operation, complete unit stops

1. Faulty outdoor control board, replace AP1

EU



Decrease in Frequency due to over heating of Module

Status:

All units operate with decrease in capacity

1. After the unit is off for 20 minutes, check for sufficient thermal grease on IPM module of the outdoor control board and that is seated tightly.
2. Faulty control board, replace

FH



Decrease frequency due to anti-freezing

Status:

All units operate with decrease in capacity

1. Poor air return in indoor unit
2. Fan speed too slow

Error Code Diagnostics

E1 - E3 Error Codes

Fault & Status

Possible Causes

E1



High Pressure Protection of System

Status:

During cooling & dehumidifying, indoor unit operates while other functions stop; During heating operation, complete unit stops

1. Refrigerant overcharge
2. Dirty outdoor coil
3. Blockage of airflow
4. Outdoor ambient too high

E2



Antifreeze Protection

Status:

Cooling operation, compressor stops while indoor fans runs. Heating operation, complete unit stops

1. Poor air return in indoor unit
2. Fan speed abnormal
3. Indoor coil dirty

E3



Low Pressure Protection

Status:

Cooling operation, compressor stops while indoor fans runs. Heating operation, complete unit stops

1. Low refrigerant charge

Error Code Diagnostics

E4 Error Code

E4



High Discharge Temperature Protection of Compressor.

Status:

Cooling operation, compressor stops while indoor fans runs. Heating operation, complete unit stops

1. Faulty outdoor temperature sensor
2. Refrigerant leak
3. Poor airflow of outdoor unit
4. Follow Troubleshooting procedure

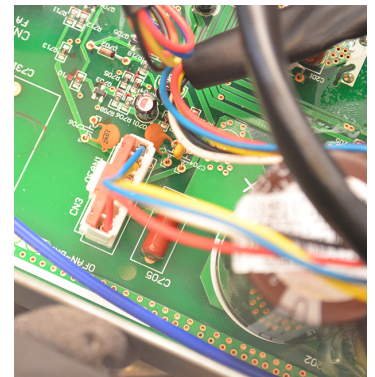
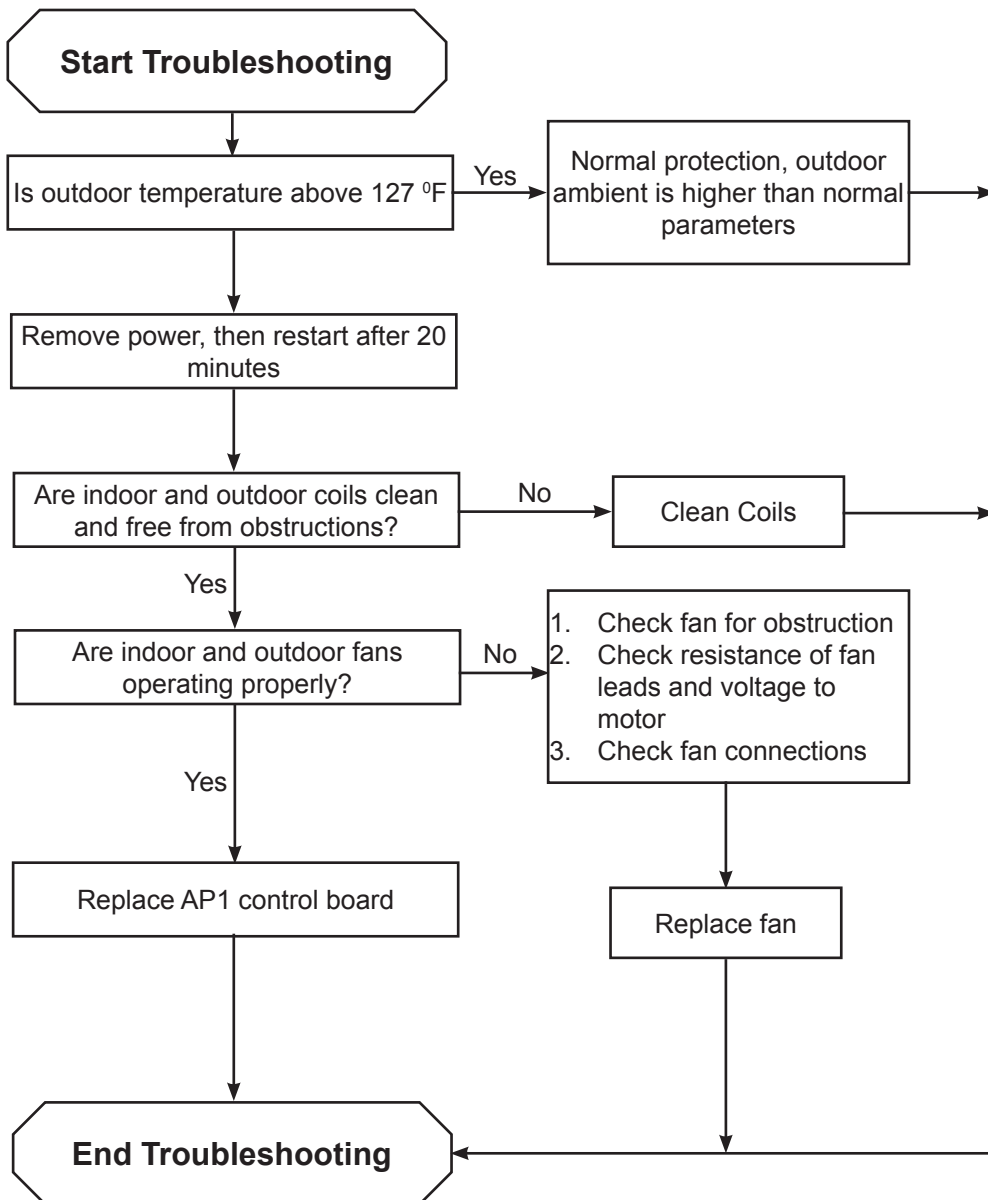

Outdoor Fan Connection

Error Code Diagnostics

E5 - E6 Error Codes

Fault & Status

Possible Causes

E5



Overcurrent Protection

Status:

During cooling & dehumidifying, indoor unit operates while other functions stop; During heating operation, complete unit stops

1. Supply voltage is unstable
2. Supply voltage is too low
3. Coils are dirty
4. Improper refrigerant charge

E6



Communication Failure

Status:

Cooling operation, compressor stops while indoor fans runs. Heating operation, complete unit stops

1. Refer to troubleshooting procedure next page

Error Code Diagnostics

E6 Error Code

E6



Communication Failure

Status:

Cooling operation, compressor stops while indoor fans runs. Heating operation, complete unit stops

1. Improper voltages
2. Mis-matched indoor and outdoor units
3. Improper wiring between indoor and outdoor units

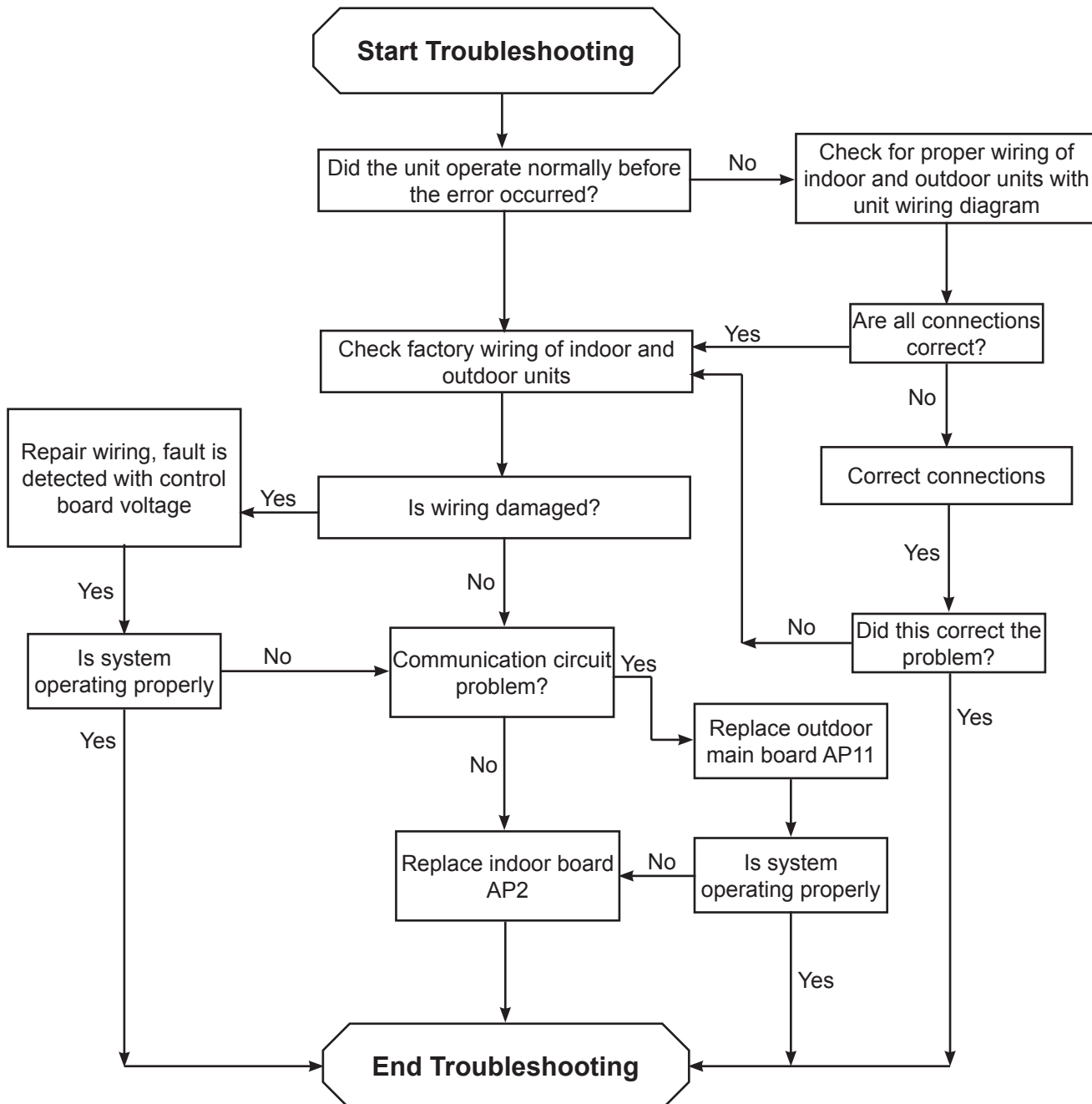

Error Code Diagnostics

E8 Error Code

E8



Overload System Protection Problem

Status:

Cooling operation, compressor stops while indoor fans runs. Heating operation, complete unit stops

1. Incorrect refrigerant charge
2. Metering device problem
3. Compressor failure

Start Troubleshooting after unit is powered off for 20 minutes

Is the overload protector positioned and wired correctly?

No



Compressor Overload

Under normal ambient conditions, is the resistance of the overload less than 1000 ohms?

No

Replace Overload

Are the wires to the expansion valve connected per the wiring diagram?

No

Correct wiring problem



Metering Device

Resistance between the first 4 pins and the 5th pin should be less than 100 ohms

Replace coil of electronic expansion valve

Is system operating normal?

Yes

No

Check Refrigerant for leakage and proper charge

Replace outdoor AP1 control board

Is system working properly?

Yes

End Troubleshooting

Error Code Diagnostics

F1 - F5 Temperature Sensor Codes

See troubleshooting chart next page

Fault & Status

Possible Causes

F1



Indoor ambient temperature sensor is open or short circuited.

Status:

During cooling & dehumidifying, indoor unit operates while other functions stop; During heating operation, complete unit stops

1. Loose or bad contact of indoor temperature sensor
2. Sensor wire leads not properly connected
3. Faulty sensor, check readings with charts
4. Main circuit board defective

F2



Indoor evaporator temperature sensor is open or short circuited.

Status:

After reaching set-point, all components stop operation, cooling and heating modes

1. Loose or bad contact of indoor temperature sensor
2. Sensor wire leads not properly connected
3. Faulty sensor, check readings with charts
4. Main circuit board defective

F3



Outdoor ambient temperature sensor is open or short circuited.

Status:

Cooling operation, compressor stops while indoor fans runs. Heating operation, complete unit stops

1. Loose or bad contact of outdoor temperature sensor
2. Sensor wire leads not properly connected
3. Faulty sensor, check readings with charts
4. Main circuit board defective

F4



Outdoor condenser temperature sensor is open or short circuited.

Status:

Cooling operation, compressor stops while indoor fans runs. Heating operation, complete unit stops

1. Loose or bad contact of outdoor temperature sensor
2. Sensor wire leads not properly connected
3. Faulty sensor, check readings with charts
4. Main circuit board defective

F5



Outdoor discharge temperature sensor is open or short circuited.

Status:

Cooling operation, compressor stops after 3 minutes while indoor fans runs. Heating operation, complete unit stops after operating for 3 minutes

1. Loose or bad contact of outdoor temperature sensor, head of sensor should be inserted into the copper tubing
2. Sensor wire leads not properly connected
3. Faulty sensor, check readings with charts
4. Main circuit board defective

Temperature Sensor Troubleshooting

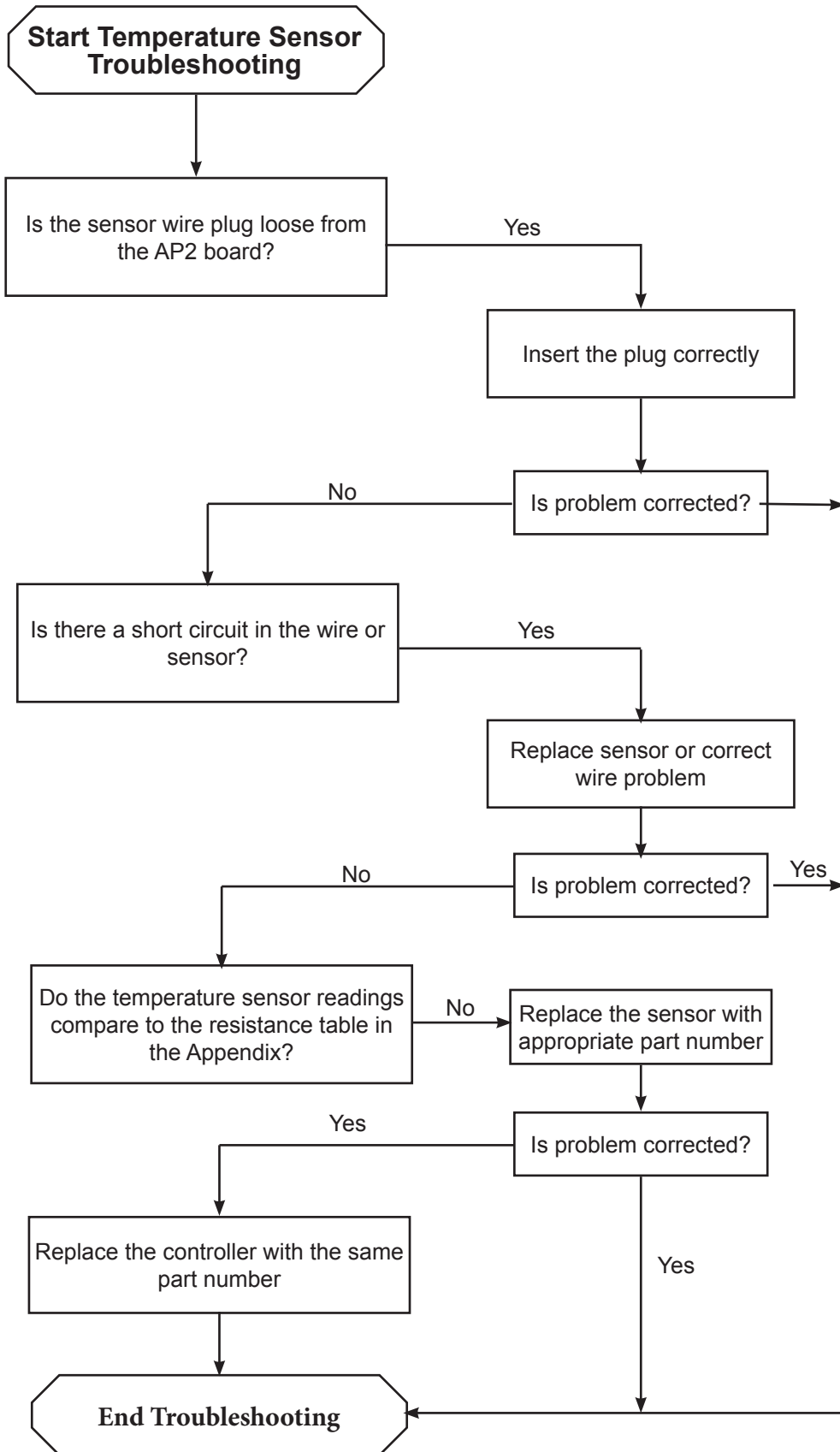

Sensor Connections

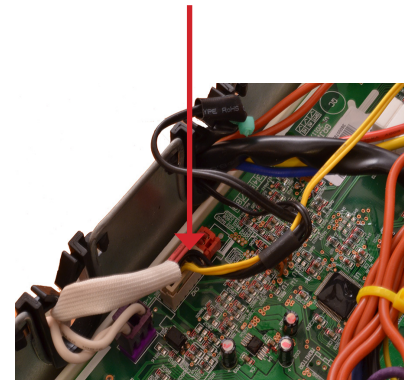

Error Code Diagnostics

F6 - F9 Temperature Sensor Codes

See troubleshooting chart next page

Fault & Status

Possible Causes

F6



Decrease frequency due to overload.

Status:

All systems operate normal with decrease in capacity

1. Refer to "E8" troubleshooting procedures

F7



Oil Return in Cooling

Normal function

F8



Decrease frequency due to overcurrent.

Status:

All systems operate normal with decrease in capacity

1. Input voltage too low.
2. System pressure is too high

F9



Decrease frequency due to high discharge air.

Status:

All systems operate normal with decrease in capacity

1. Cooling load is too great
2. Outdoor ambient too high
3. Refrigerant undercharge
4. Electronic expansion valve fault

Start-up Failure Troubleshooting

Lc - Start-up Failure

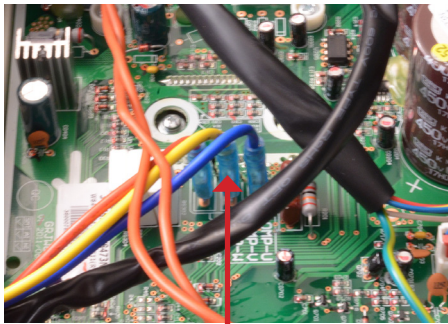

Compressor Terminals

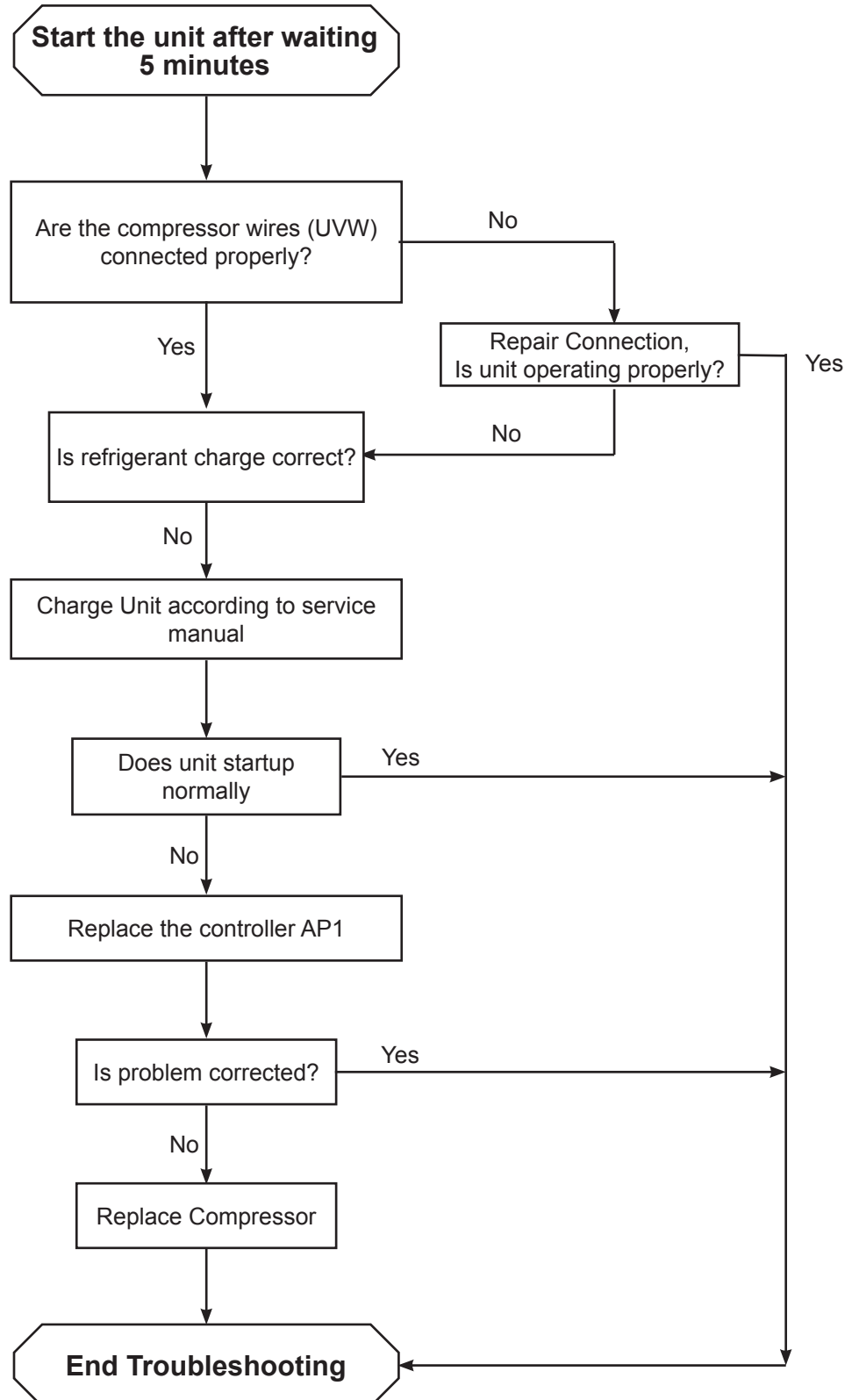

Error Code Diagnostics

HC Error Code

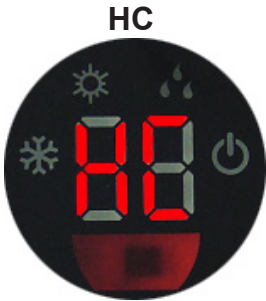

HC

PFC (Power Factor Correction) Protection

Status:

During cooling & dehumidifying, indoor unit operates while other functions stop; During heating operation, complete unit stops

1. Check for damage to the reactor and PFC capacitor of the outdoor unit
2. Refer to troubleshooting procedure below

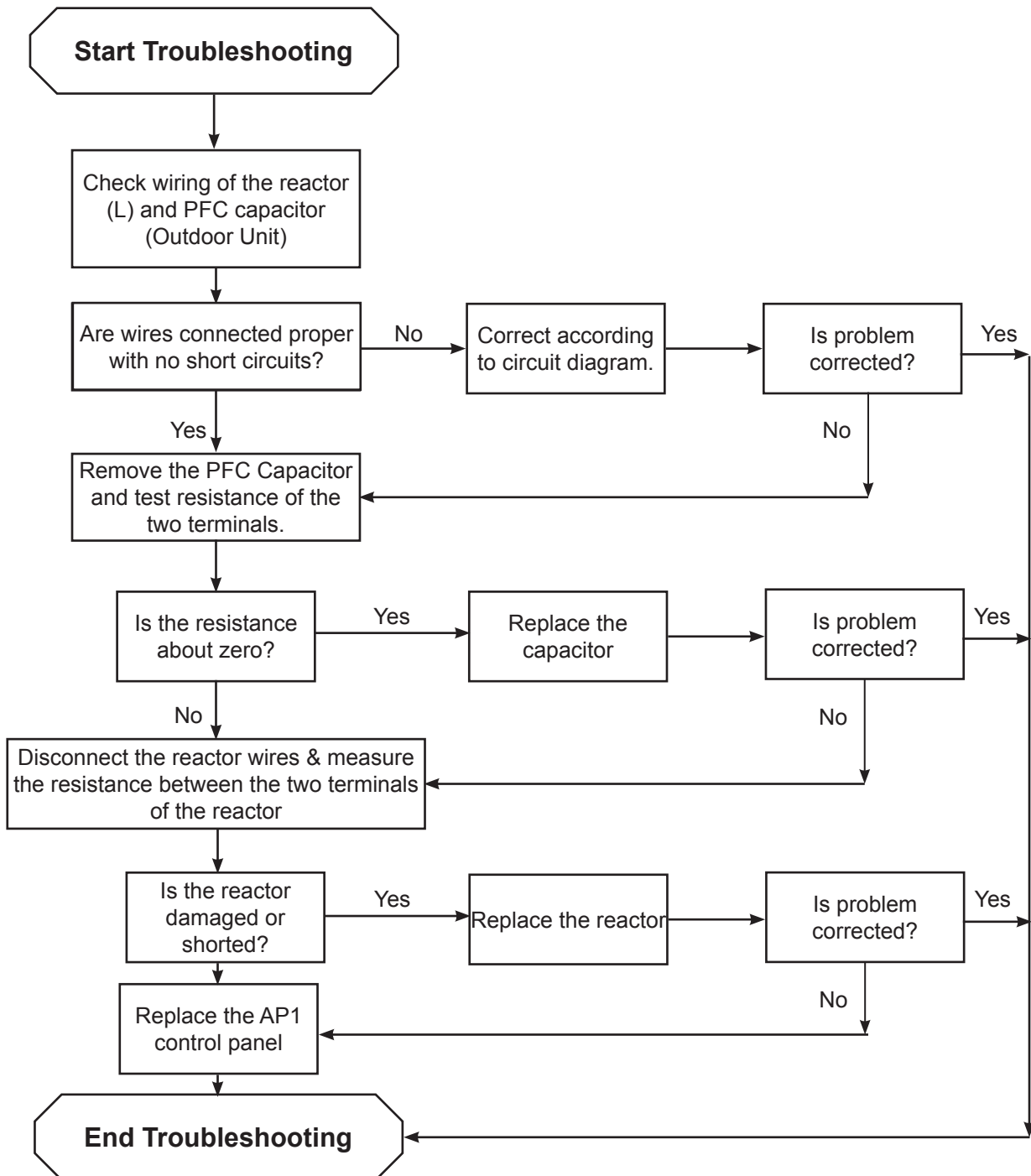

Error Code Diagnostics

H0 - H3 Error Codes

Fault & Status

Possible Causes

H0



Decrease frequency due to overload.

Status:

All systems operate normal with decrease in capacity

1. Refer to "E8" troubleshooting procedures

H1



Defrosting

Status:

Defrosting will occur in heating mode. Compressor will operate while indoor fan stops.

Normal function

H2



Static Dedusting Protection

H3



Overload Protection for Compressor

Status:

During cooling mode, compressor will stop, indoor fan will run. Heating mode all units stop.

1. Wiring terminal OVC-COMP is loose. In normal state the resistance should be less than 1 ohm,
2. Refer to "E4" troubleshooting procedures.

Error Code Diagnostics

H4 - H6 Error Codes

Fault & Status

Possible Causes

H4



System is Abnormal

Status:

During cooling mode, compressor will stop, indoor fan will run. Heating mode all units stop.

1. Refer to "E8" troubleshooting procedures

H5



IPM Protection

Status:

During cooling mode, compressor will stop, indoor fan will run. Heating mode all units stop.

1. Refer to "H7" troubleshooting procedures

H6



Indoor Fan Motor will not run

Status:

Indoor fan, Outdoor fan & compressor will stop. Louver stops at present location.

1. Bad connection of DC motor feedback terminal
2. Bad connection of DC motor control end
3. Check Fan Capacitor if in Use
4. Fan motor is stalling, check for obstructions
5. Motor malfunction
6. Malfunction of main board

Error Code Diagnostics

H7 Error Code, continued on next page

H7



Desynchronizing of compressor

Status:

During cooling mode, compressor will stop, indoor fan will run. Heating mode all units stop.

1. Check the resistance of the compressor terminals and connections to the compressor
2. Check for overcharge of refrigerant
3. Check for correct voltage

Troubleshooting Procedure for Synchronizing Fault after Unit is Started

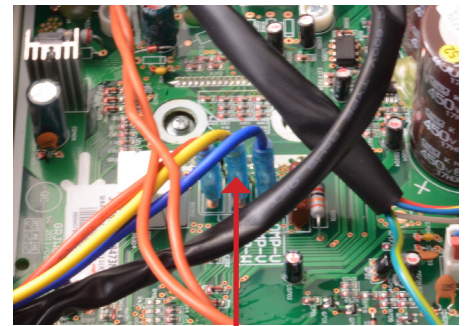
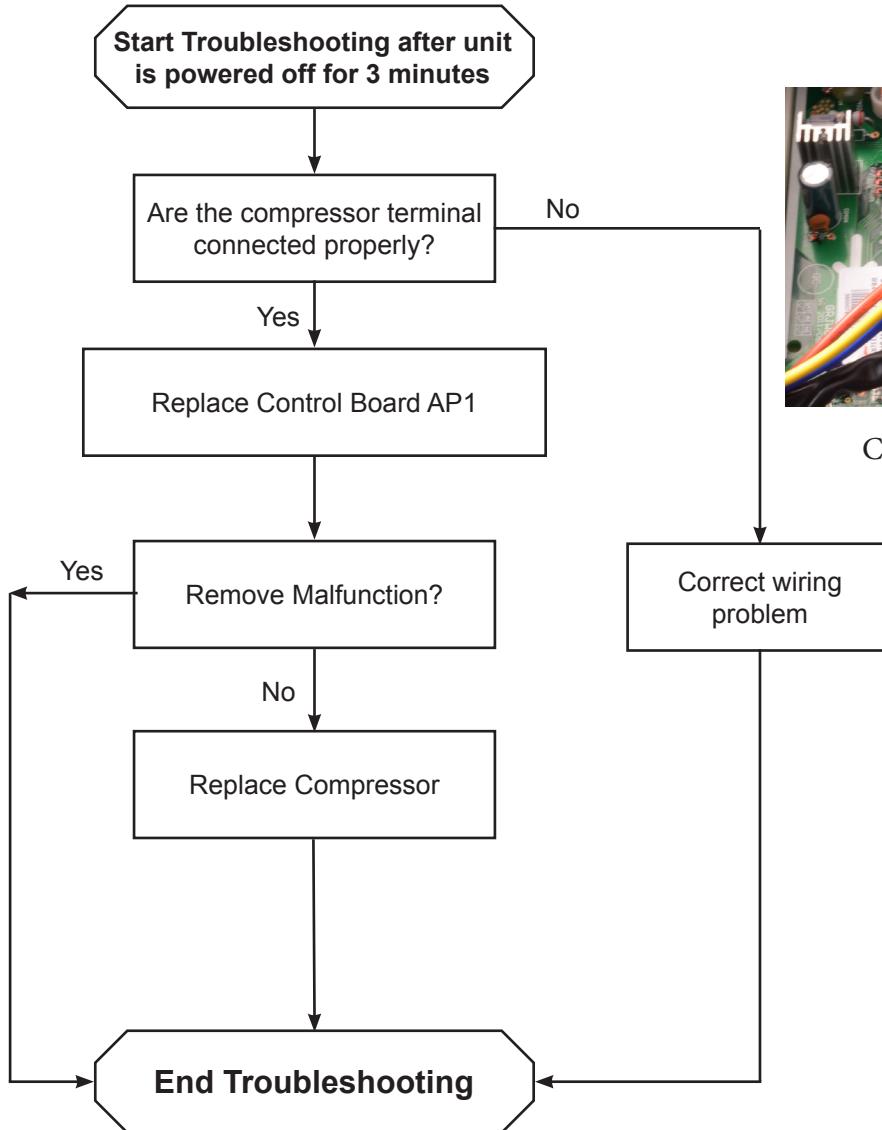

Compressor Terminals

Error Code Diagnostics

H7 Error Code, continued

H7



Desynchronizing of compressor

Status:

During cooling mode, compressor will stop, indoor fan will run. Heating mode all units stop.

1. Check the resistance of the compressor terminals and connections to the compressor
2. Check for overcharge of refrigerant
3. Check for correct voltage

Troubleshooting Procedure for Synchronizing Fault During Operation

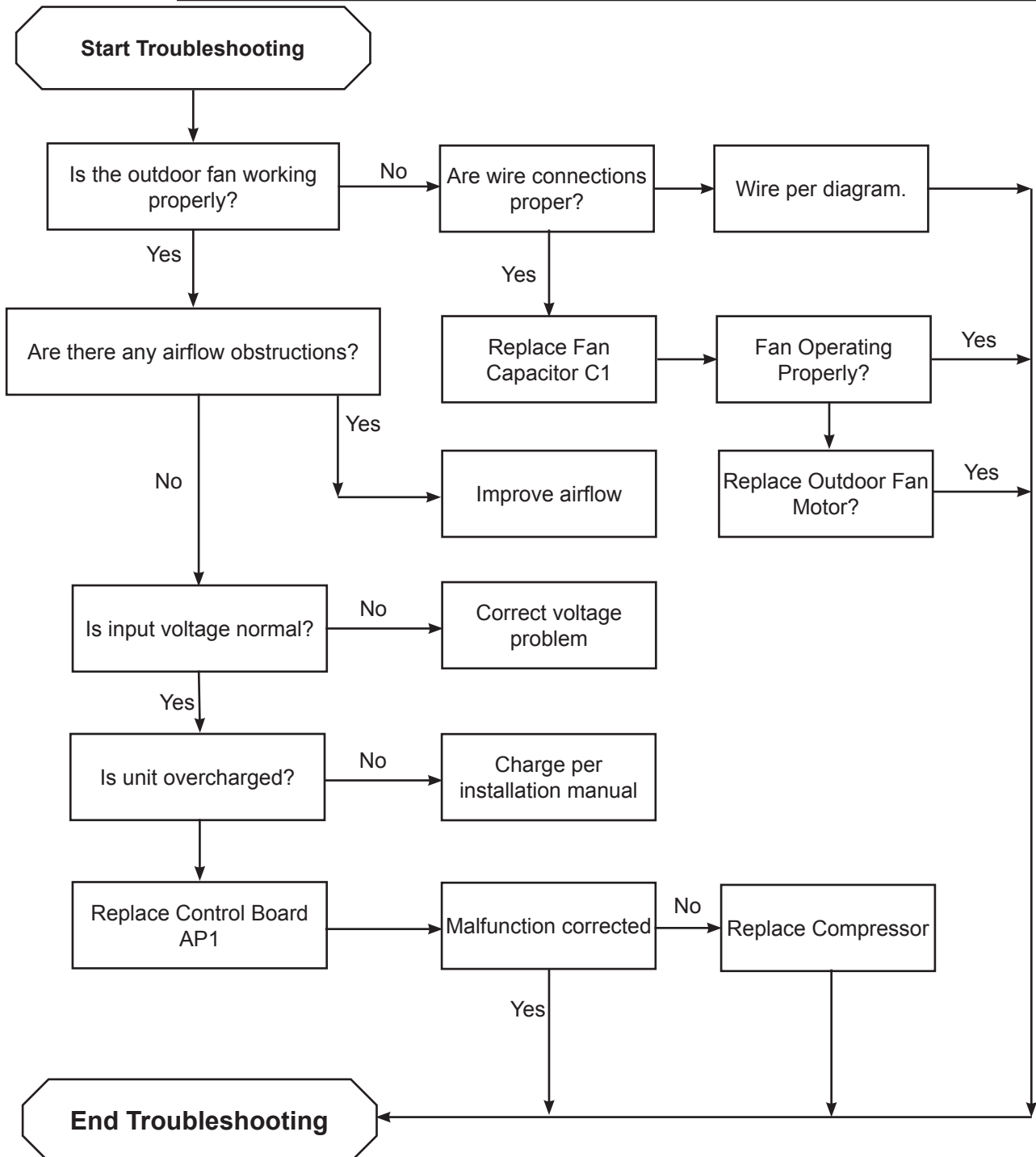

Error Code Diagnostics

U1, U3, U5, U7, U9 Error Codes

Fault & Status

Possible Causes

U1



Compressor Phase Detection Error

Status:

During cooling mode, compressor will stop, indoor fan will run. Heating mode all units stop.

1. Replace outdoor control panel AP1

U3



DC Bus-Bar Voltage Unstable

Status:

During cooling mode, compressor will stop, indoor fan will run. Heating mode all units stop.

1. Supply voltage is unstable

U5



Circuit Board Malfunction on Outdoor Unit

Status:

During cooling mode, compressor will stop, indoor fan will run. Heating mode all units stop.

1. Replace outdoor control panel AP1

U7



Reversing Valve Malfunction

Status:

During heating mode, complete unit will stop

1. Supply voltage is too low
2. Wiring terminal on reversing valve is loose or broken
3. Replace reversing valve

U9



Zero crossing, malfunction of Outdoor Unit

Status:

During cooling mode, compressor will stop, indoor fan will run. Heating mode all units stop.

1. Replace outdoor control panel AP1

Error Code Diagnostics

PH, PL, P5, P7, P8 Error Codes

Fault & Status

Possible Causes

PH



High DC Bus-Bar Voltage

Status:

During cooling mode, compressor will stop, indoor fan will run. Heating mode all units stop.

1. Measure the voltage on "L" & "N" on line voltage, if it is higher then 265vac, correct high voltage.
2. If AC voltage is normal, measure the voltage on the electrolytic capacitor on control panel AP1, if it is normal replace the AP1 board.

PL



Low DC Bus-Bar Voltage

Status:

During cooling mode, compressor will stop, indoor fan will run. Heating mode all units stop.

1. Measure the voltage on "L" & "N" on line voltage, if it is lower then 200vac, correct incoming voltage.
2. If AC voltage is normal, measure the voltage on the electrolytic capacitor on control panel AP1, if it is normal replace the AP1 board.

P5



Overcurrent Protection of Compressor Phase Current

Status:

During heating mode, complete unit will stop

1. Refer to "H7" troubleshooting

P7



Module Temperature Sensor Circuit Failure

Status:

During cooling mode, compressor will stop, indoor fan will run. Heating mode all units stop.

1. Replace outdoor control panel AP1

P8



Module High Temperature Protection

Status:

During cooling mode, compressor will stop, indoor fan will run. Heating mode all units stop.

1. After unit is de-energized for 20 minutes, check for proper thermal grease on IPM module of outdoor control panel AP1 and contact is good. If this is OK, replace AP1 control module of outdoor unit.

Error Code Diagnostics

PU Error Code

PU



Charging Malfunction of Capacitor

Status:

During cooling mode, compressor will stop, indoor fan will run. Heating mode all units stop.

1. Improper input voltage
2. Poor connection on reactor
3. Reactor damaged
4. Bad AP1 control board

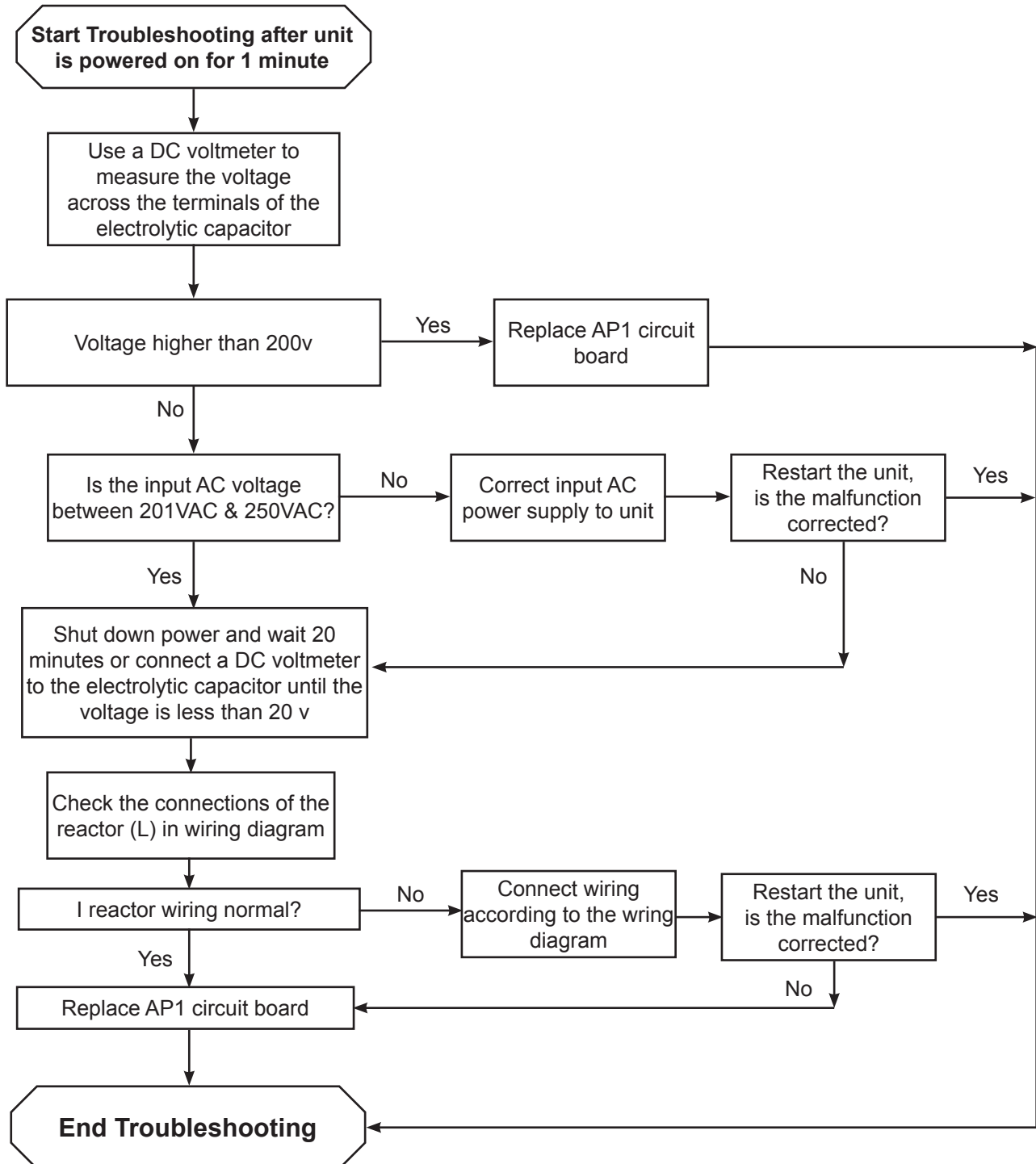

Disassembly of Indoor Unit

9,000 & 12,000 btuh **Warning - Wait 10 minutes after power is disconnected before starting disassembly.**

1. Before disassembly of indoor unit

Before disassembly of indoor unit

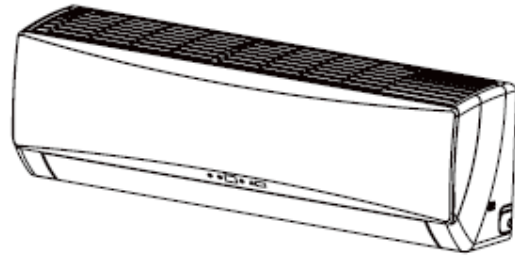

2. Remove filter

Step 1. Open the panel

Step 2. Loosen the clasps on the filter, push the filter inward, then pull upward, removing the filter.

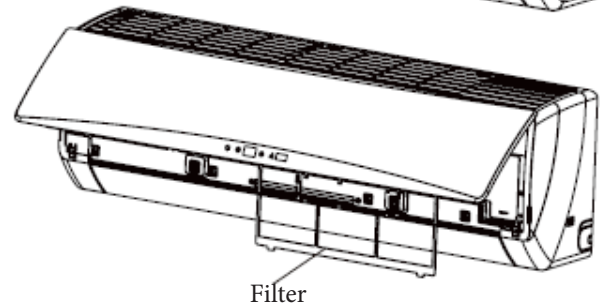
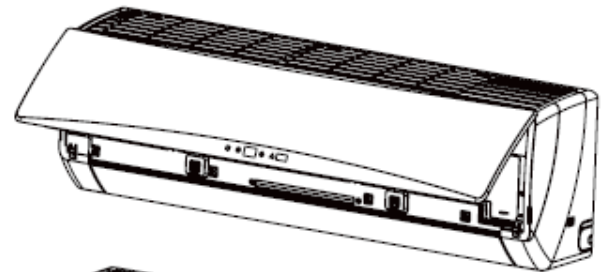

3. Remove guide louver

Step 1. Remove the axial bushing of the big guide louver

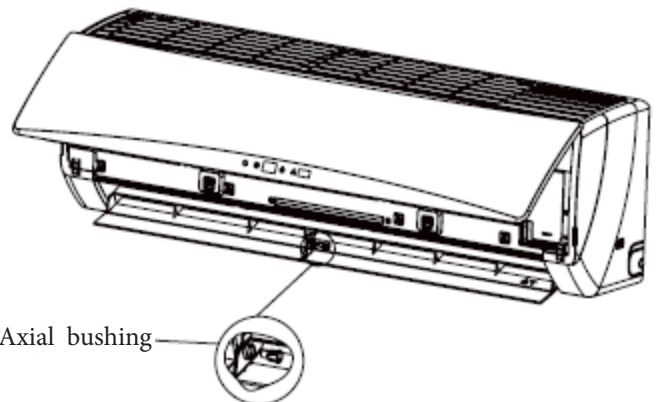

Disassembly of Indoor Unit

9,000 & 12,000 btuh **Warning - Wait 10 minutes after power is disconnected before starting disassembly.**

3. Remove guide louver, continued

Step 2. Remove the rotating shaft of the big guide louver from the groove, slightly bend the big guide louver to remove it.

Step 3. Remove the axial bushing of the small guide louver

Step 4. Remove the rotating shaft of the small guide louver from the groove, slightly bend the small guide louver to remove it.

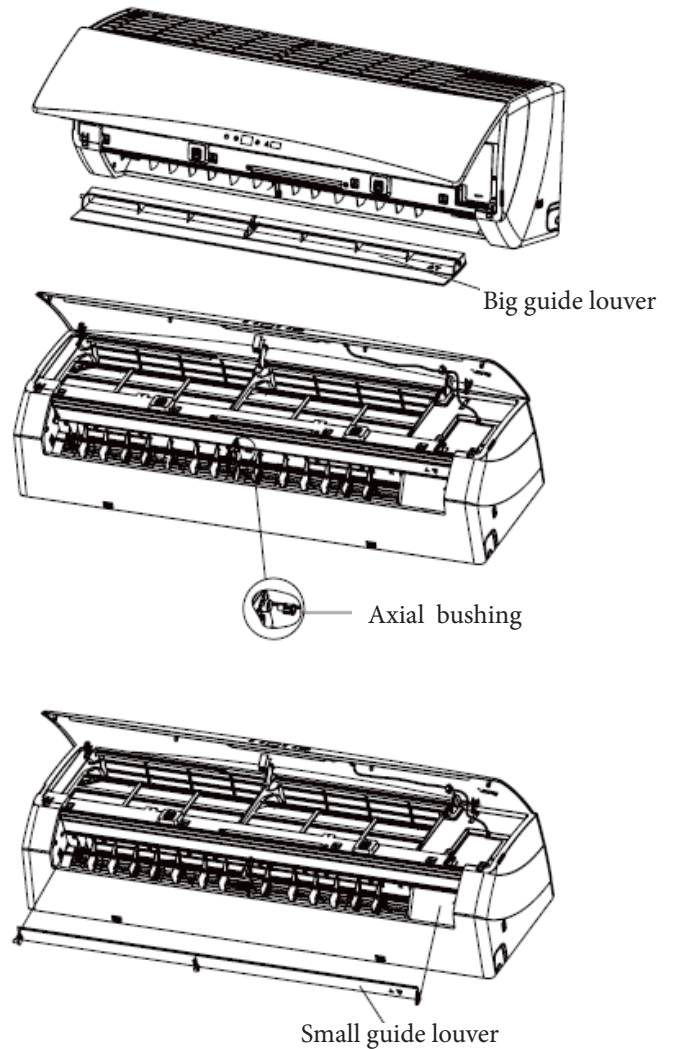

4. Remove panel

Step 1. Loosen the clamps of the panel to remove panel.

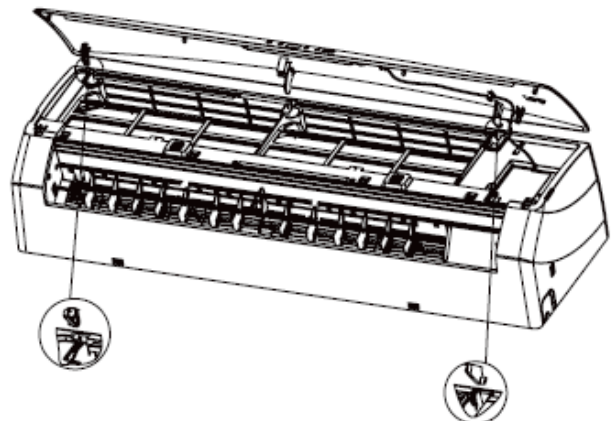

Disassembly of Indoor Unit

9,000 & 12,000 btuh **Warning - Wait 10 minutes after power is disconnected before starting disassembly.**

4. Remove panel, continued

Step 2. Remove the screws holding the display.

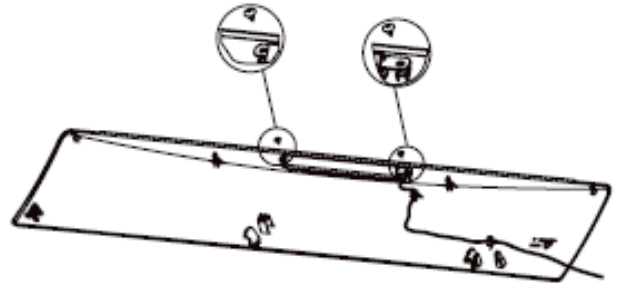

5. Remove front case

Step 1. Remove the screws fastening the electrical box cover to remove cover.

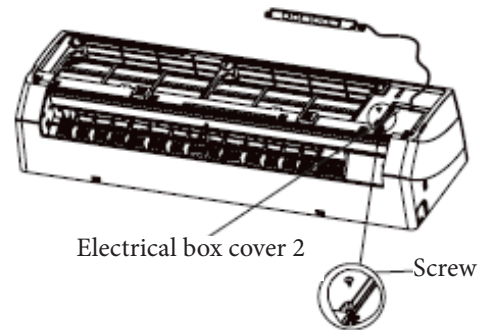

Step 2. Remove the screws holding the front cover, loosen clamps, then remove cover.

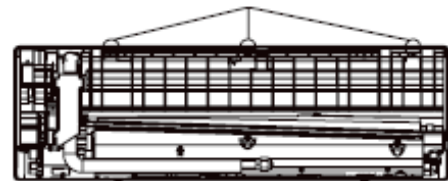
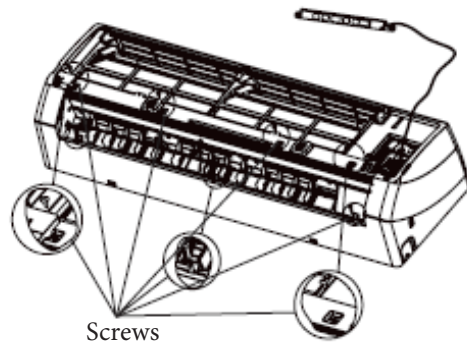

Disassembly of Indoor Unit

9,000 & 12,000 btuh **Warning - Wait 10 minutes after power is disconnected before starting disassembly.**

6. Remove swing fan blade

Step 1. Remove the four screws holding the protective grille, then remove the grille. Loosen the clamps holding the swing connector and remove the connecting rod.

Step 2. Remove the clamps holding the swing fan blade, then remove the blade

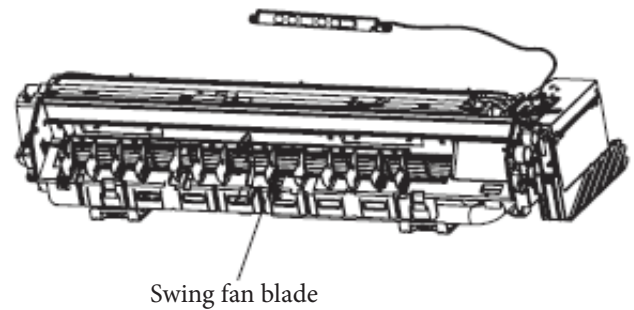
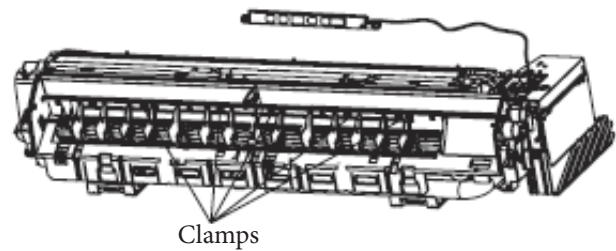
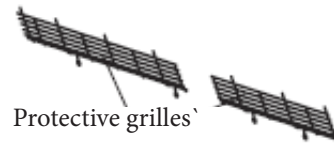
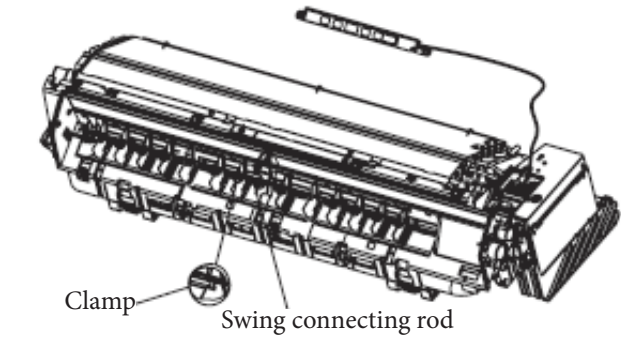

Disassembly of Indoor Unit

9,000 & 12,000 btuh **Warning - Wait 10 minutes after power is disconnected before starting disassembly.**

7. Remove electrical box sub-assembly

Step 1. Remove the indoor tube temperature sensor

Step 2. Remove the screws holding the bonding wire, then remove the wire

Step 3. Remove the clamps holding the electrical box cover to remove cover.

Step 4. Remove all wiring terminals, remove all screws holding the box, then remove the sub-assembly.

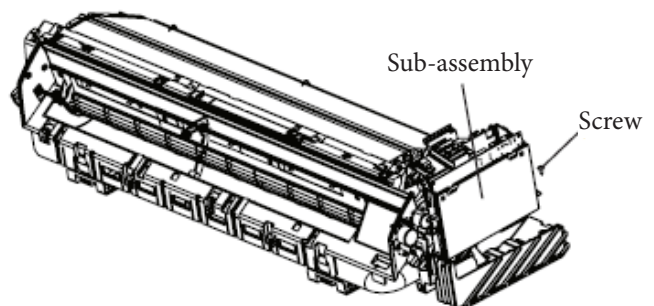
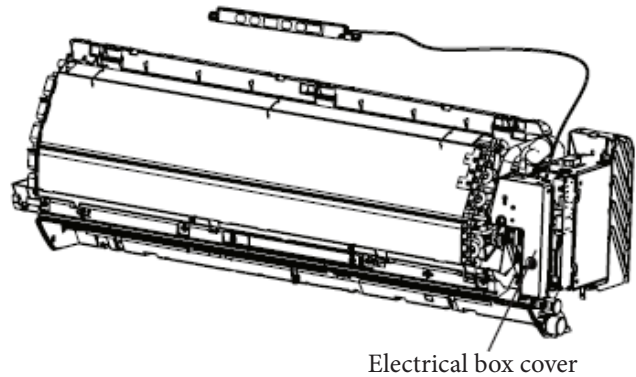
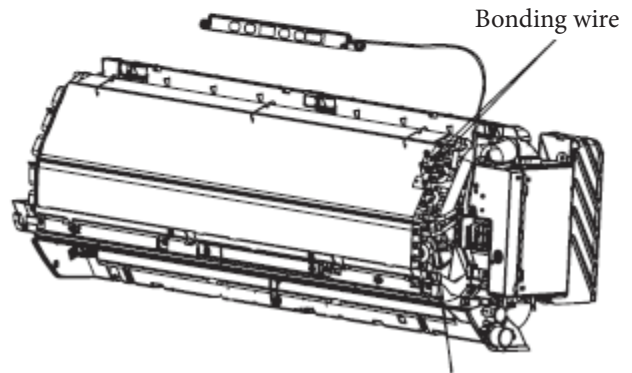
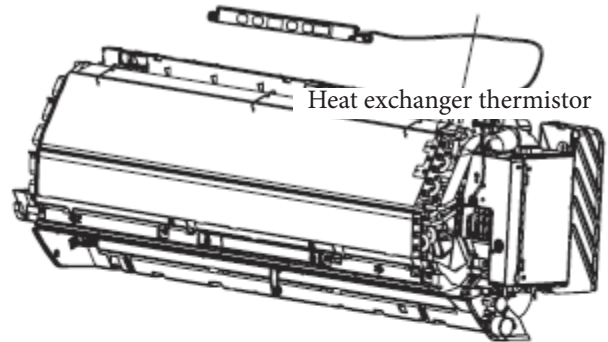

Disassembly of Indoor Unit

9,000 & 12,000 btuh **Warning - Wait 10 minutes after power is disconnected before starting disassembly.**

8. Remove evaporator sub-assembly

Step 1. Remove the screws holding the pipe clamp.

Step 2. Remove the screws holding the evaporator sub-assembly, slightly reposition the tubing to remove the evaporator.

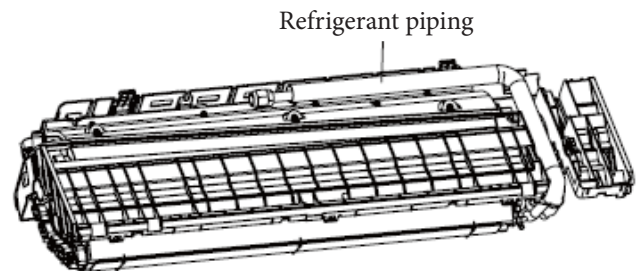
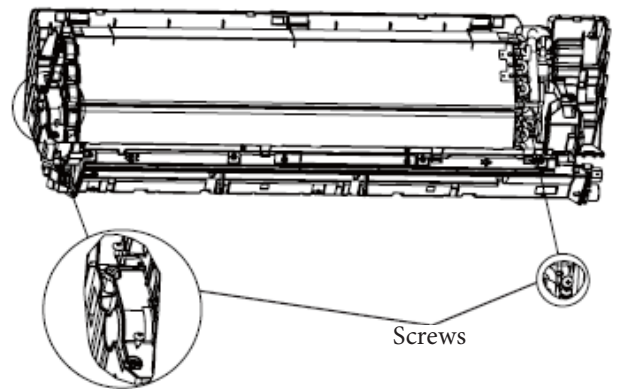
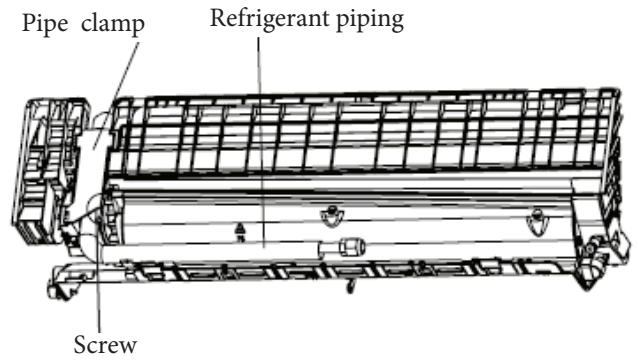

Evaporator sub-assembly

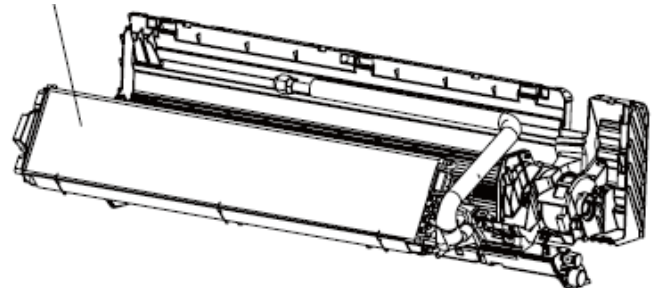

Disassembly of Indoor Unit

9,000 & 12,000 btuh **Warning - Wait 10 minutes after power is disconnected before starting disassembly.**

9. Remove indoor fan blade and motor

Step 1. Remove the screws holding the up/down swing motor to remove motor

Step 2. Remove the screws holding the left/right swing motor to remove motor

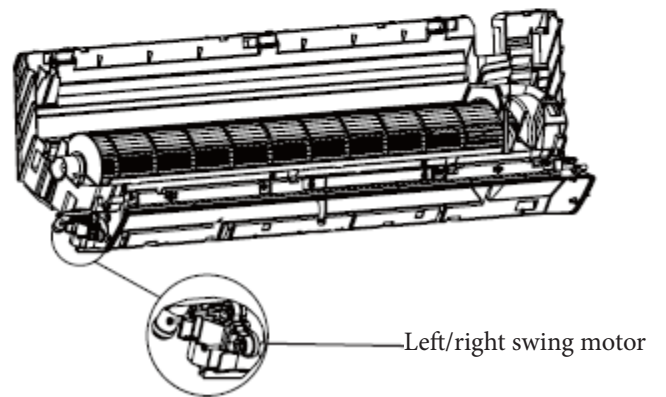
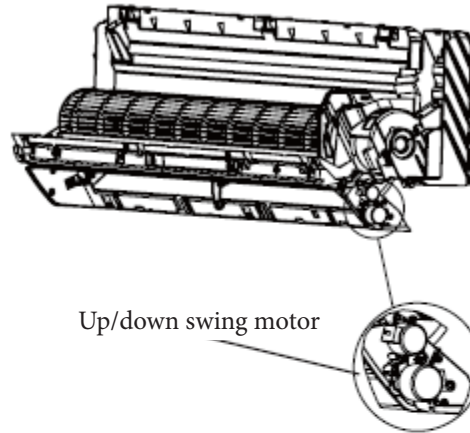

Disassembly of Indoor Unit

9,000 & 12,000 btuh **Warning - Wait 10 minutes after power is disconnected before starting disassembly.**

9. Remove indoor fan blade and motor, cont.

Step 3. Remove the screws holding the motor clamp.

Step 2. Remove the fan blade and motor

Step3. Remove the shaft bearing rubber cushion.

Step 4. Remove the screws holding the fan blade and motor, then remove the motor.

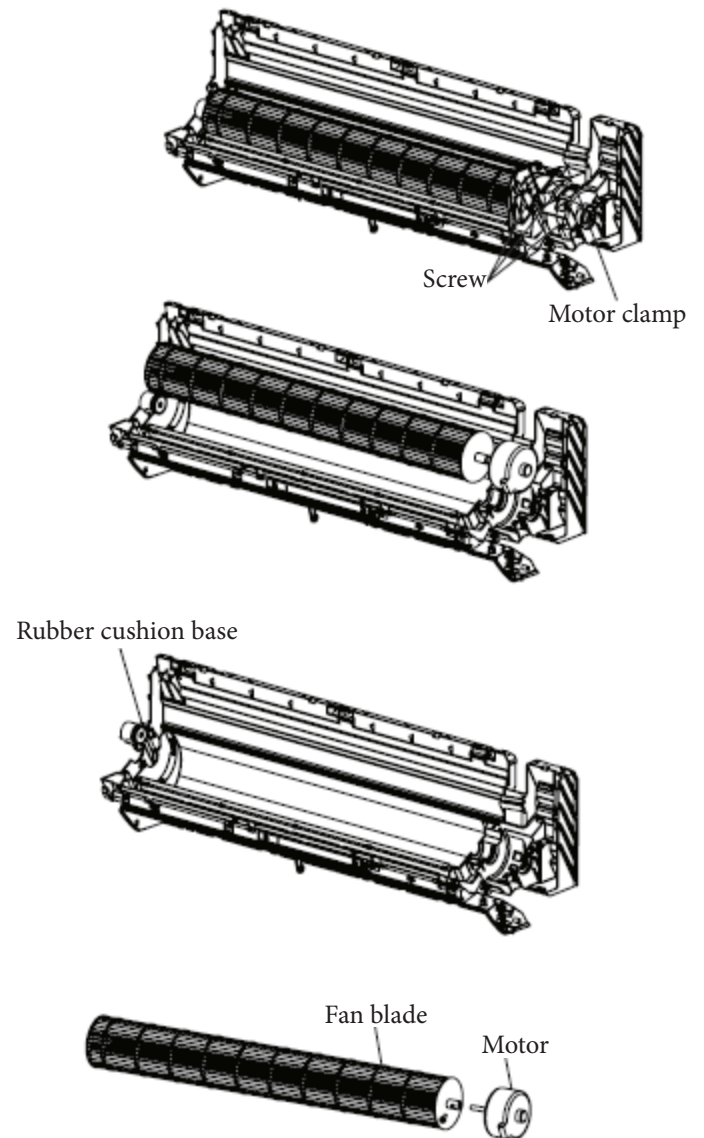

Disassembly of Indoor Unit

18,000 btuh *Warning - Wait 10 minutes after power is disconnected before starting disassembly.*

1. Before disassembly of indoor unit

Before disassembly of indoor unit

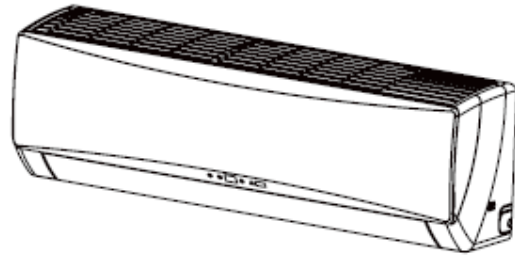

2. Remove filter

Step 1. Open the panel

Step 2. Loosen the clasps on the filter, push the filter inward, then pull upward, removing the filter.

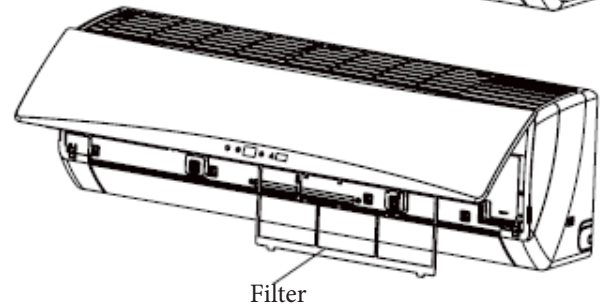
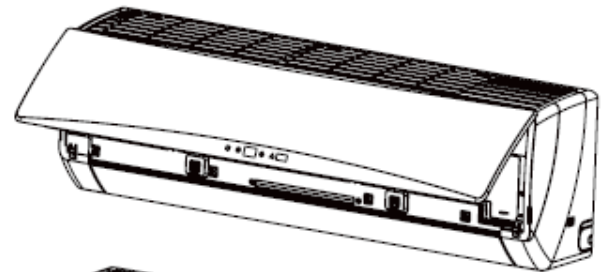

3. Remove guide louver

Step 1. Remove the axial bushings of the big guide louver

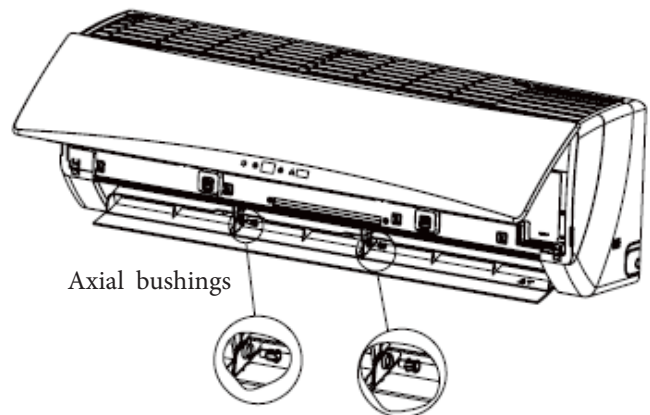

Disassembly of Indoor Unit

18,000 btuh **Warning - Wait 10 minutes after power is disconnected before starting disassembly.**

3. Remove guide louver, continued

Step 2. Remove the rotating shaft of the big guide louver from the groove, slightly bend the big guide louver to remove it.

Step 3. Remove the axial bushing of the small guide louver

Step 4. Remove the rotating shaft of the small guide louver from the groove, slightly bend the small guide louver to remove it.

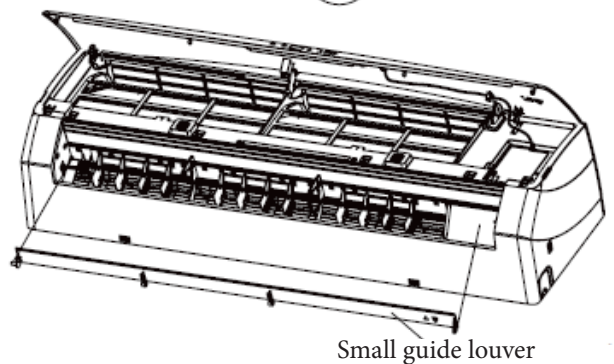
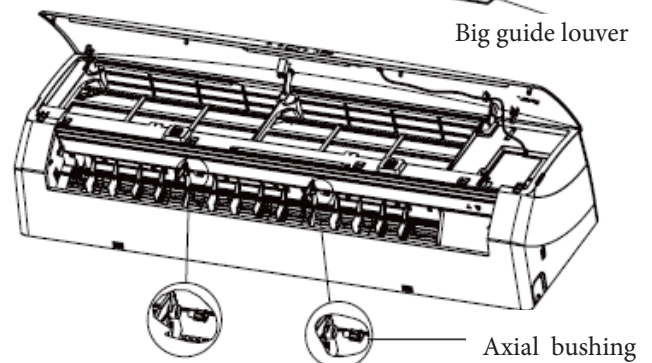
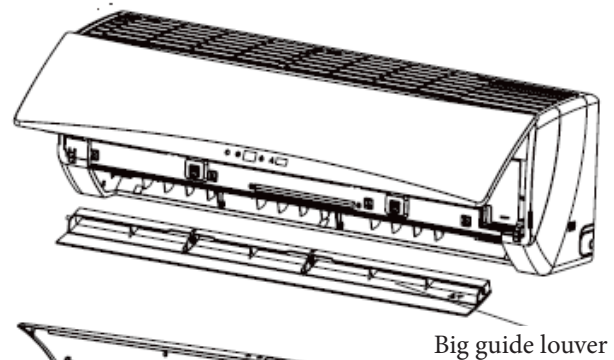

4. Remove panel

Step 1. Loosen the clamps holding the panel, then remove panel.

Step 2. Remove the screws holding the display, then remove display

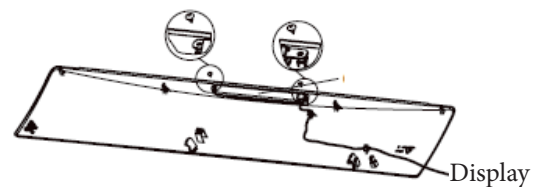
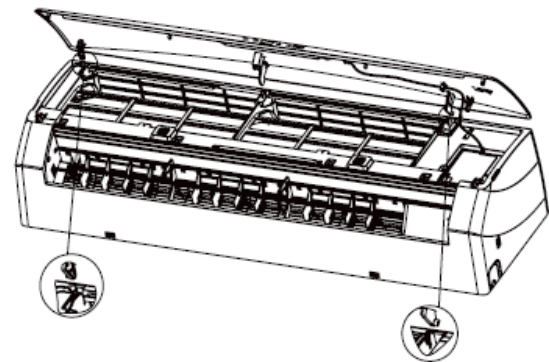

Disassembly of Indoor Unit

18,000 btuh **Warning - Wait 10 minutes after power is disconnected before starting disassembly.**

5. Remove front case

Step 1. Remove the screws fastening the electrical box cover to remove cover.

Step 2. Remove the screws holding the front cover, loosen clamps, then remove cover.

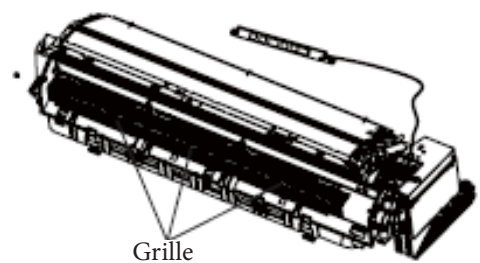
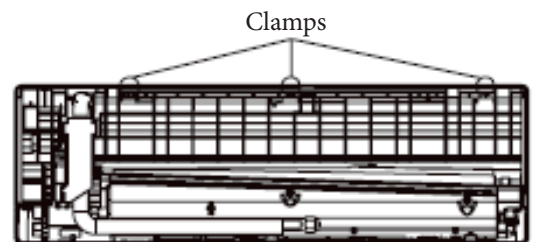
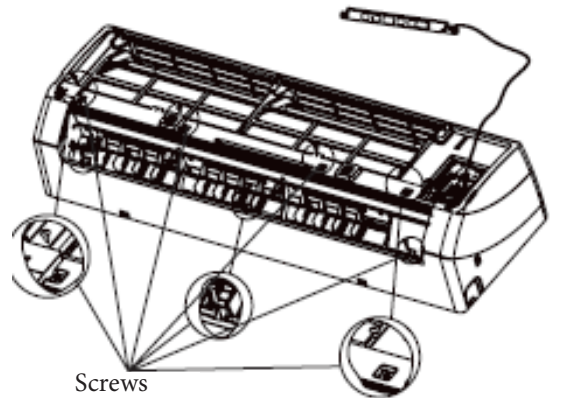
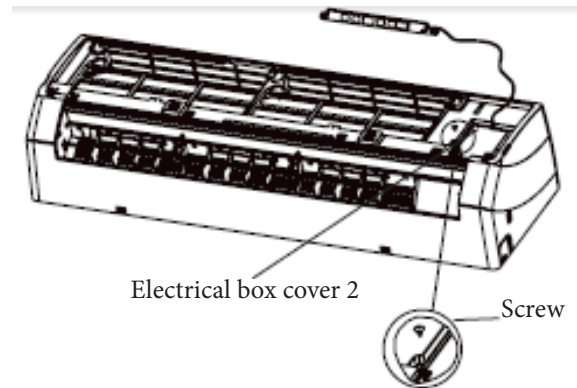

Disassembly of Indoor Unit

18,000 btuh **Warning - Wait 10 minutes after power is disconnected before starting disassembly.**

6. Remove swing fan blade

Step 1. Remove the clamps holding the swing fan connecting rod to remove the connecting rod.

Step 2. Remove the clamps holding the swing fan blade to remove the blade.

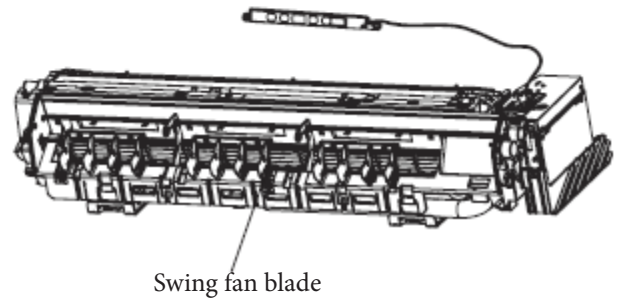
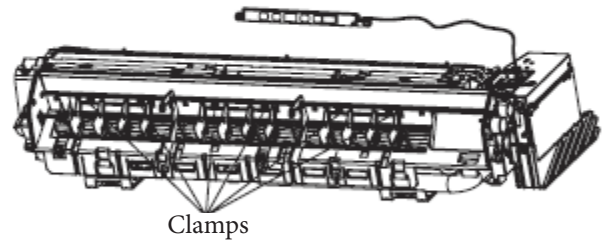
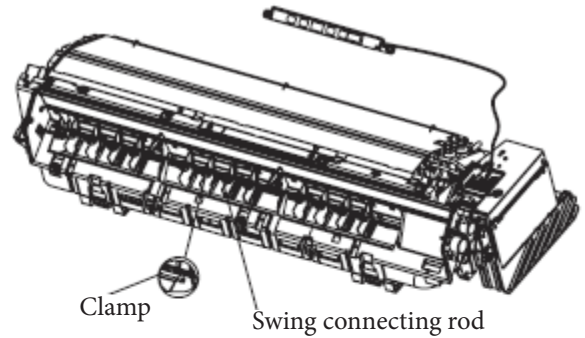

Disassembly of Indoor Unit

18,000 btuh **Warning - Wait 10 minutes after power is disconnected before starting disassembly.**

7. Remove electrical box sub-assembly

Step 1. Remove the indoor tube temperature sensor

Step 2. Remove the screws holding the bonding wire, then remove the wire

Step 3. Remove the clamps holding the electrical box cover to remove cover.

Step 4. Remove all wiring terminals, remove all screws holding the box, then remove the sub-assembly.

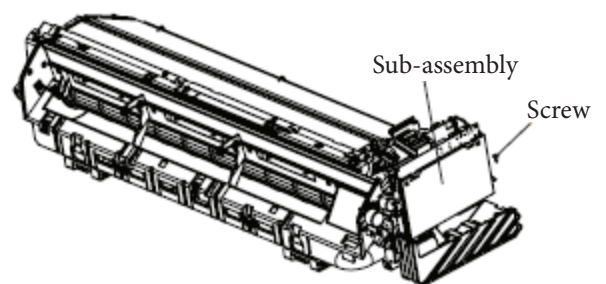
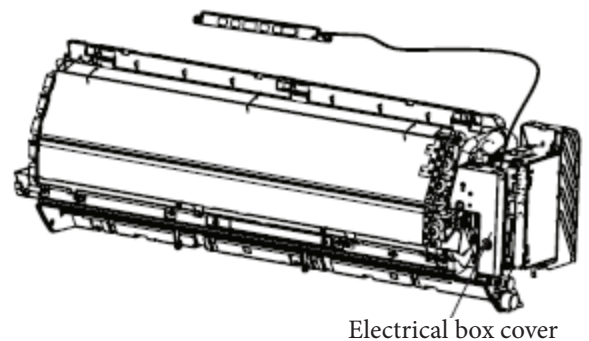
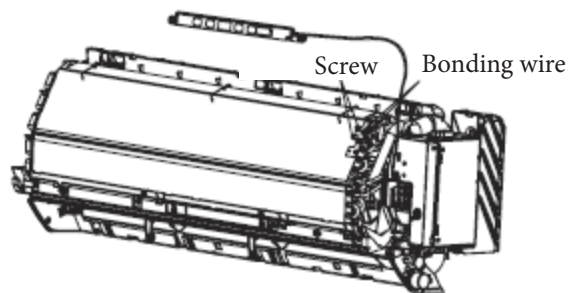
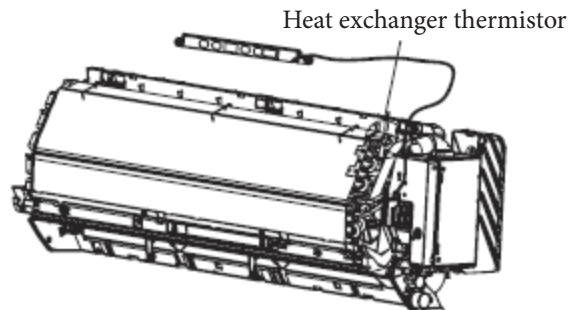

Disassembly of Indoor Unit

18,000 btuh **Warning - Wait 10 minutes after power is disconnected before starting disassembly.**

8. Remove evaporator sub-assembly

Step 1. Remove the screws holding the pipe clamp.

Step 2. Remove the screws holding the evaporator sub-assembly, slightly reposition the tubing to remove the evaporator.

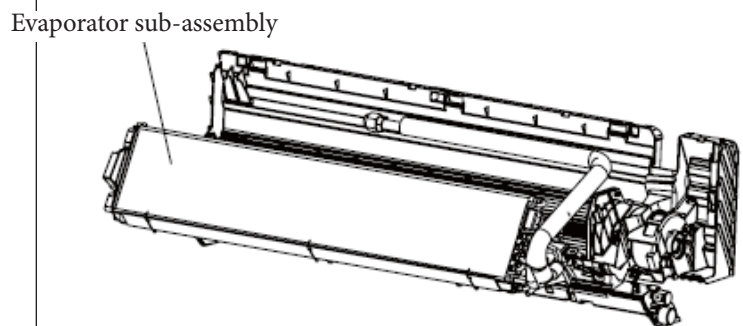
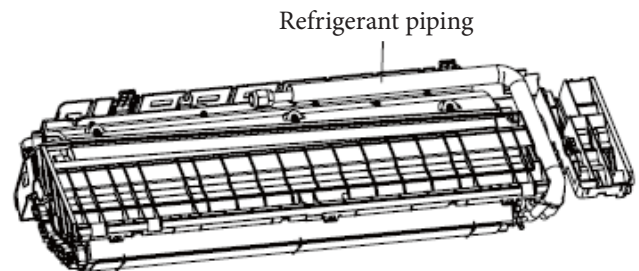
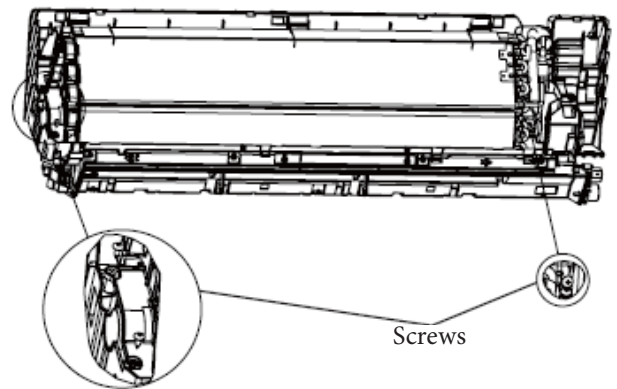
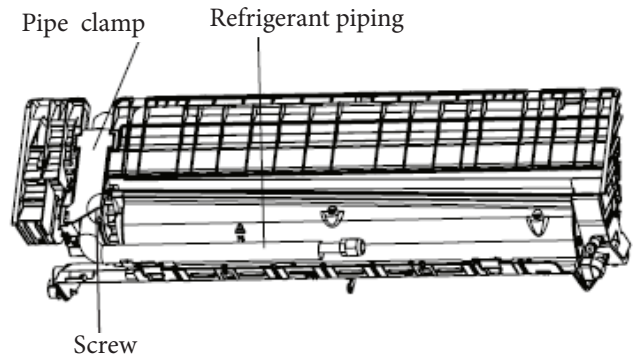

Disassembly of Indoor Unit

18,000 btuh **Warning - Wait 10 minutes after power is disconnected before starting disassembly.**

9. Remove indoor fan blade and motor

Step 1. Remove the screws holding the up/down swing motor to remove motor

Step 2. Remove the screws holding the left/right swing motor to remove motor

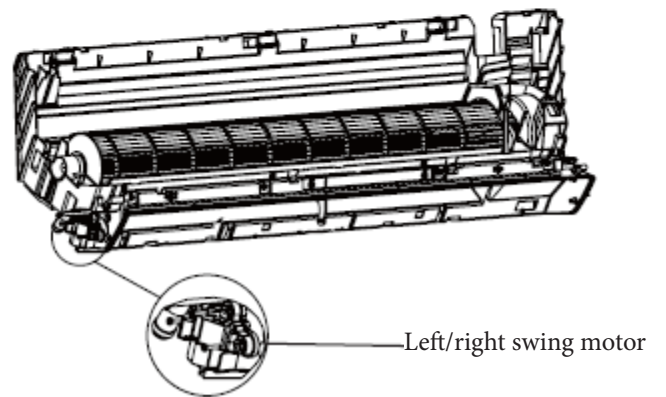
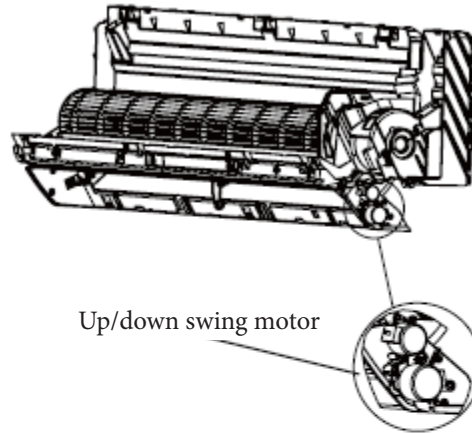

Disassembly of Indoor Unit

18,000 btuh **Warning - Wait 10 minutes after power is disconnected before starting disassembly.**

9. Remove indoor fan blade and motor, cont.

Step 3. Remove the screws holding the motor clamp.

Step 4. Remove the fan blade and motor

Step 5. Remove the shaft bearing rubber cushion.

Step 6. Remove the screws holding the fan blade and motor, then remove the motor.

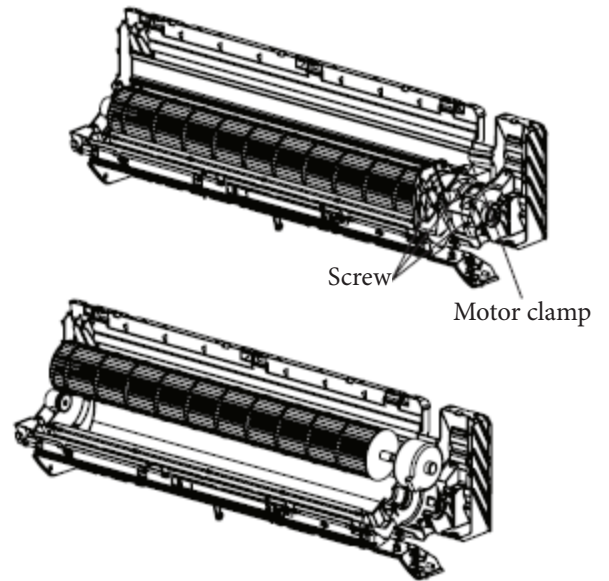

Rubber cushion base

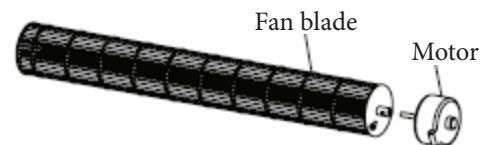
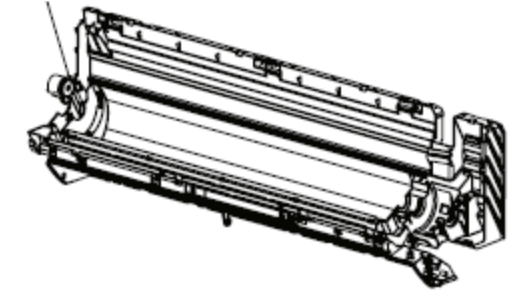

Disassembly of Indoor Unit

24,000 btuh **Warning - Wait 10 minutes after power is disconnected before starting disassembly.**

1. Before disassembly of indoor unit

Before disassembly of indoor unit

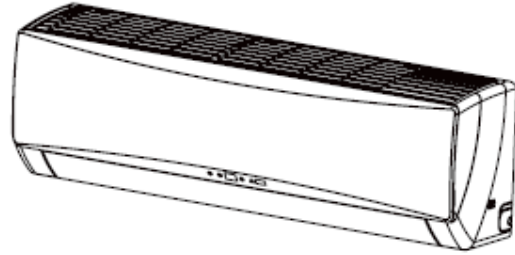

2. Remove filter

Step 1. Open the panel

Step 2. Loosen the clasps on the filter, push the filter inward, then pull upward, removing the filter.

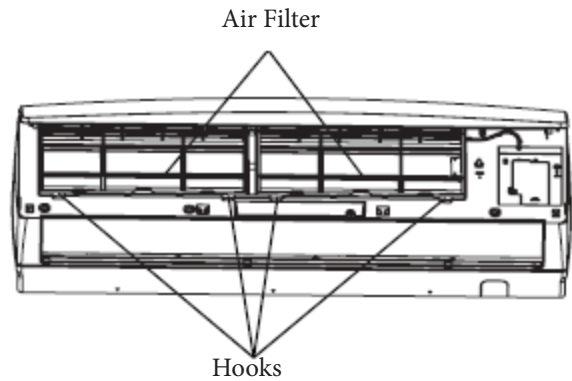
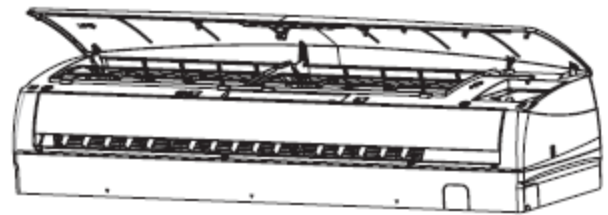

Disassembly of Indoor Unit

24,000 btuh **Warning - Wait 10 minutes after power is disconnected before starting disassembly.**

3. Remove guide louver

Step 1. Along the groove holding the front panel, slide the rotor shaft outward to remove the front panel

Step 2. Remove the panel.

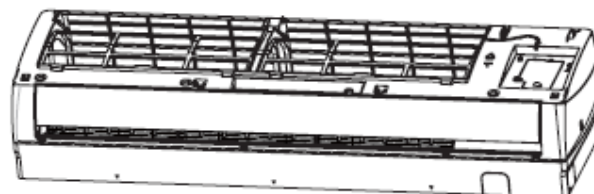
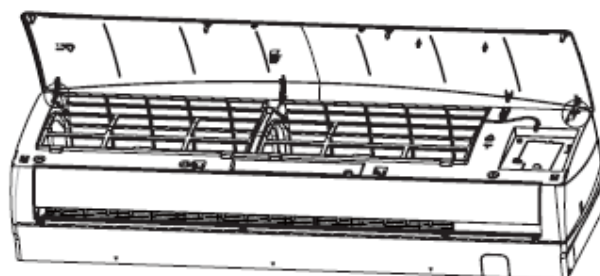
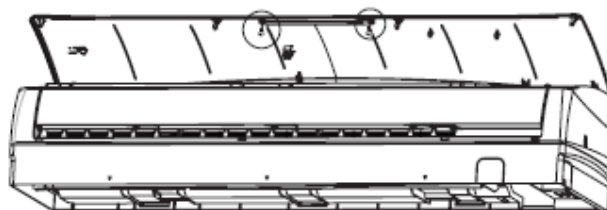

4. Remove electrical box cover

Step 1. Remove the clamps holding the swing fan connecting rod to remove the connecting rod.

Step 2. Remove the clamps holding the swing fan blade to remove the blade.

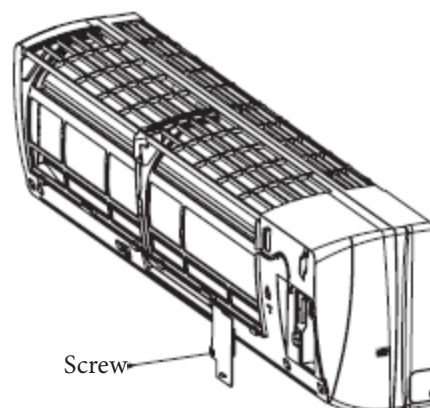

Disassembly of Indoor Unit

24,000 btuh **Warning - Wait 10 minutes after power is disconnected before starting disassembly.**

5. Remove Axial bushing

Step 1. Remove the axial bushing of horizontal louver to remove the guide louver

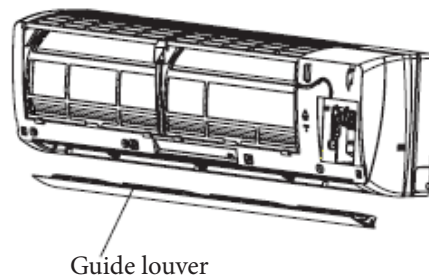
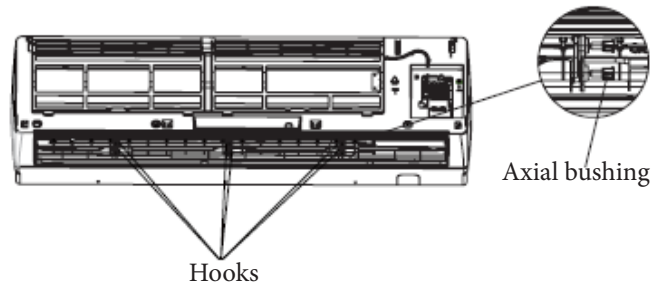

6. Remove front case

Step 1. Remove the screw cover of the front case, then remove the screws

Step 2. Remove the front case to separate the front case from the bottom assembly.

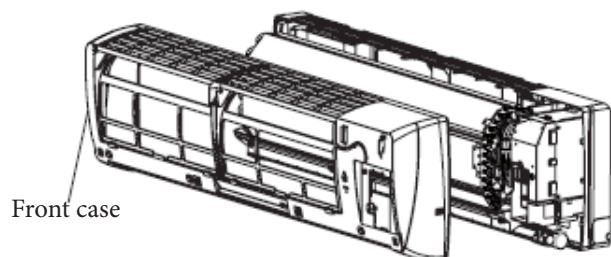
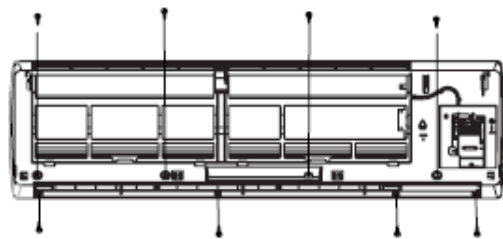
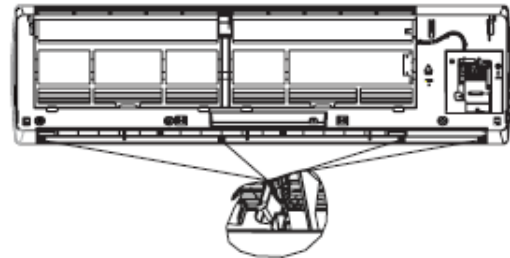

Disassembly of Indoor Unit

24,000 btuh **Warning - Wait 10 minutes after power is disconnected before starting disassembly.**

7. Remove electrical box sub-assembly

Step 1. Remove the indoor tube temperature sensor

Step 2. Remove the screws holding the bonding wire, then remove the wire

Step 3. Remove the clamps holding the electrical box cover to remove cover.

Step 4. Remove all wiring terminals, remove all screws holding the box, then remove the sub-assembly.

Temperature sensor



Electrical box cover

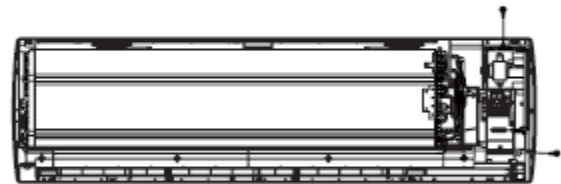
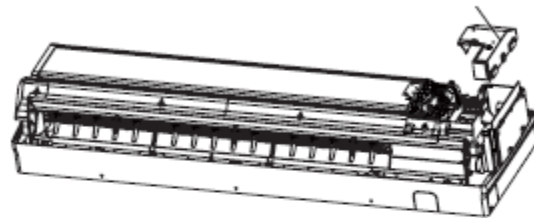

Sub-assembly

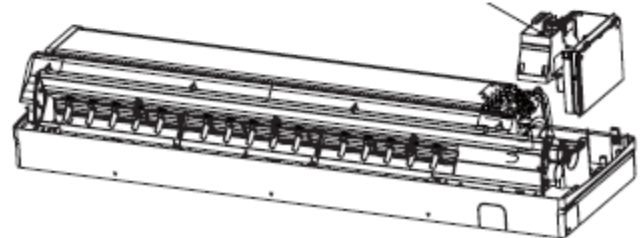

Disassembly of Indoor Unit

24,000 btuh **Warning - Wait 10 minutes after power is disconnected before starting disassembly.**

8. Remove evaporator sub-assembly

Step 1. Remove the clamps connecting the water tray and chassis, then remove the water tray.

Step 2. Remove the screws holding the tubing clamp, then remove the clamp.

Step 3. Remove the screws holding the evaporator sub-assembly, slightly reposition the tubing to remove the evaporator.

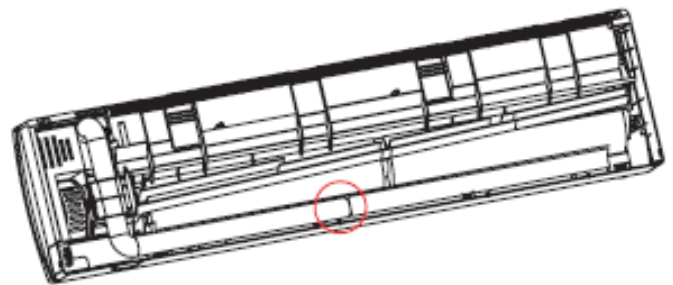
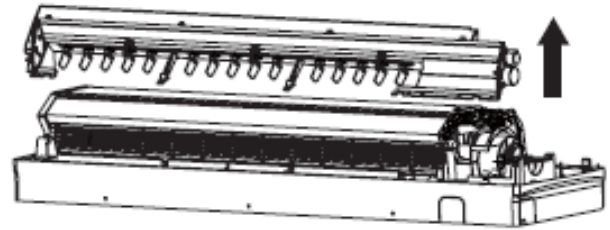

Pipe clamp

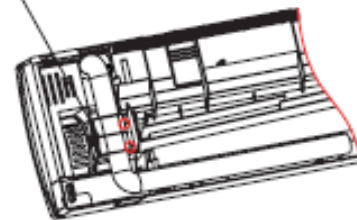

Screw

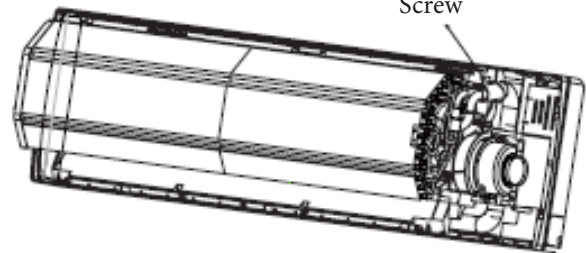

Disassembly of Indoor Unit

24,000 btuh **Warning - Wait 10 minutes after power is disconnected before starting disassembly.**

8. Remove evaporator sub-assembly, cont.

Step 4. Turn over the indoor unit and adjust the tubing to the position as shown by the broken line

Step 5. Lift up and remove the evaporator.

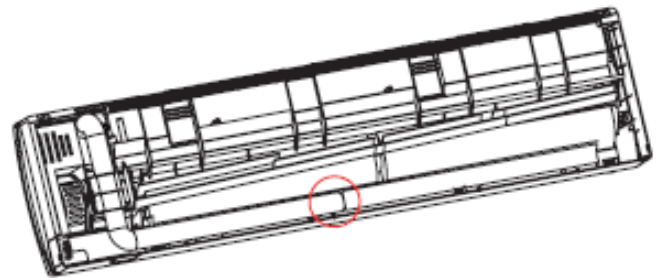
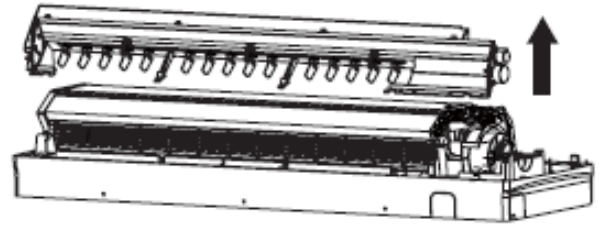

Evaporator

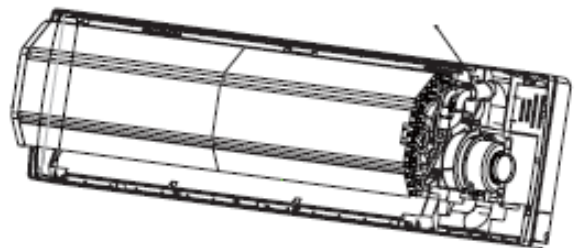
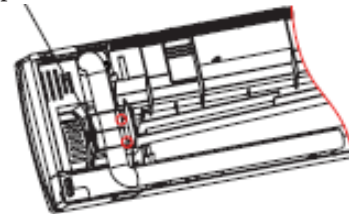

Disassembly of Indoor Unit

24,000 btuh **Warning - Wait 10 minutes after power is disconnected before starting disassembly.**

9. Remove indoor fan blade and motor, cont.

Step 1. Remove the two screws holding the step motor and remove the step motor.

Step 2. Remove the screws holding the cross flow blade and motor.

Step 3. Remove the motor sub-assembly.

Step 4. Pull out the plug of ring bearing.

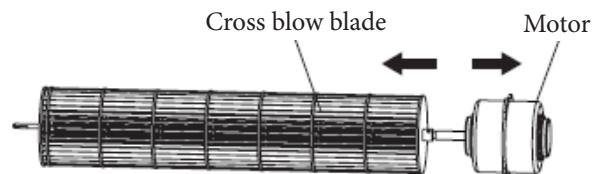
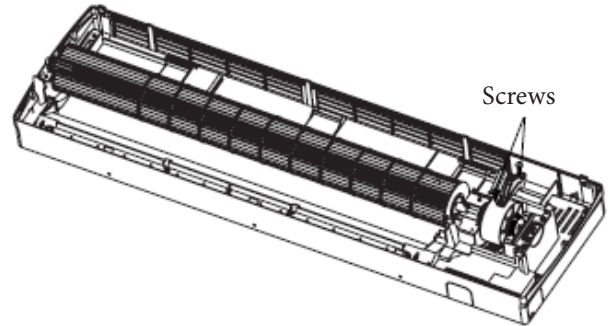

Disassembly of Outdoor Unit

9,000 & 12,000 btuh **Warning - Wait 10 minutes after power is disconnected before starting disassembly.**

1. Before Disassembly

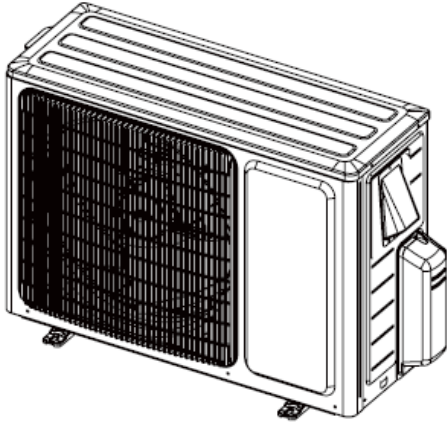

4. Remove panel and grille

Remove the screws holding the panel, Remove the screws connecting the panel grille and panel, then loosen clamp.

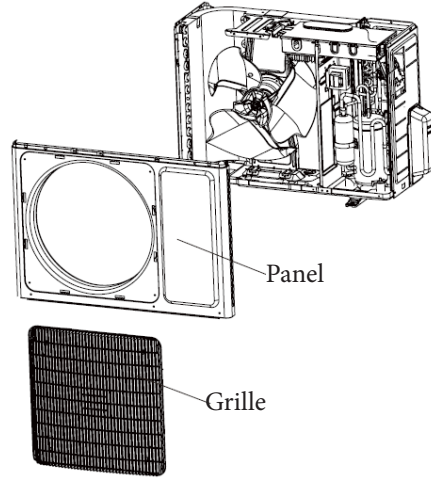

2. Remove top cover

Remove the screws connecting the top panel, left and right side panel.

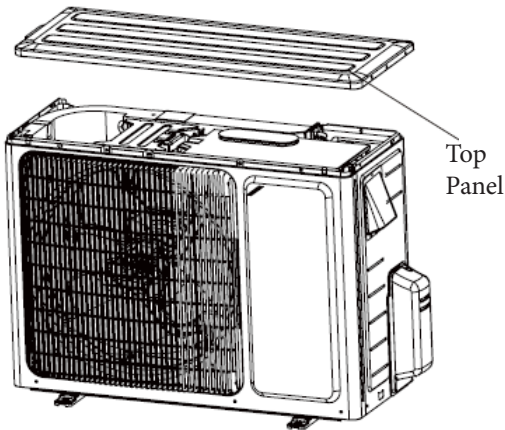

5. Remove top cover

Remove the screws holding the valve cover

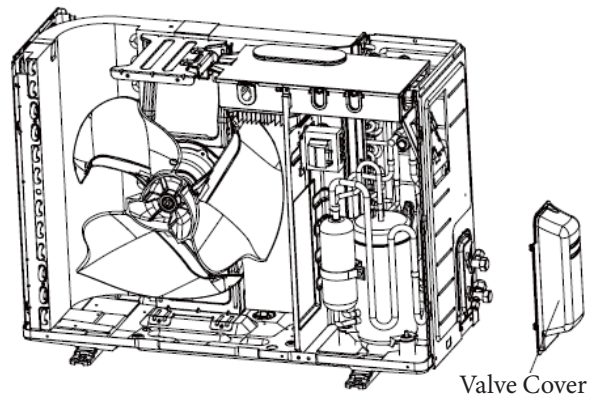

3. Remove handle

Remove the screws connecting the handle

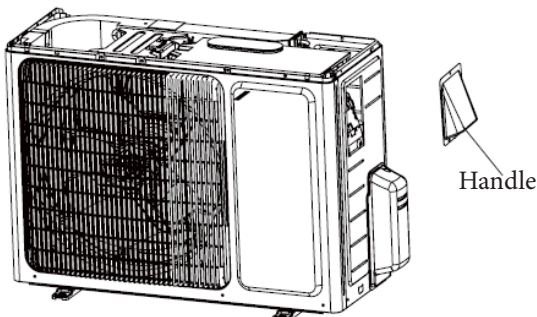

6. Remove handle

Remove the screws connecting the left side panel and condenser support board.

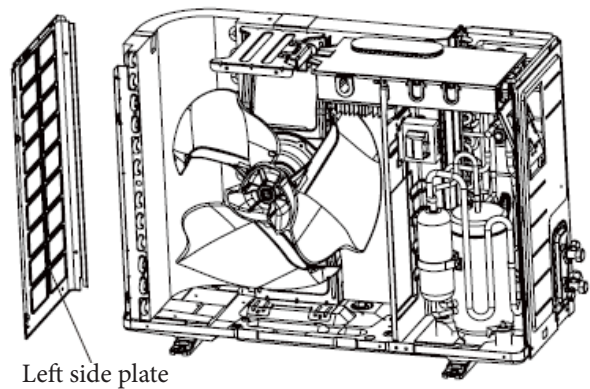

Disassembly of Outdoor Unit, continued

9,000 & 12,000 btuh **Warning - Wait 10 minutes after power is disconnected before starting disassembly.**

7. Remove fan blade

Remove the bolt holding the fan blade on motor shaft, then remove gasket and washer.

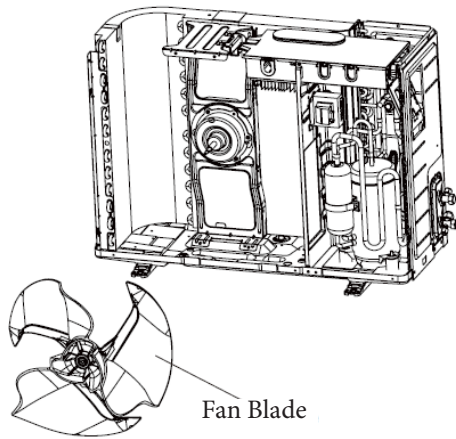

10. Remove electric reactor

Remove the screws holding the reactor to remove

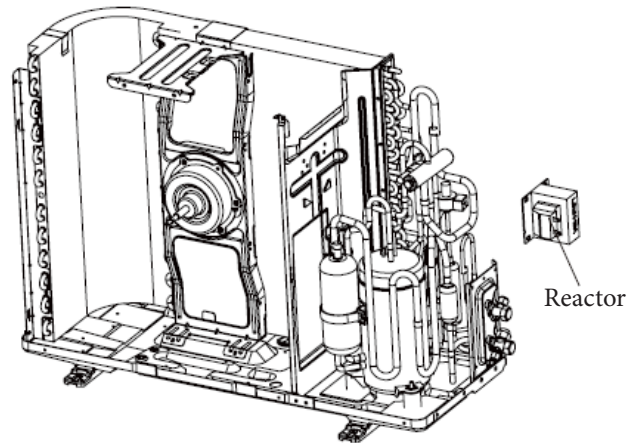

8. Remove right side panel

Remove the screws holding the right side panel and valve support

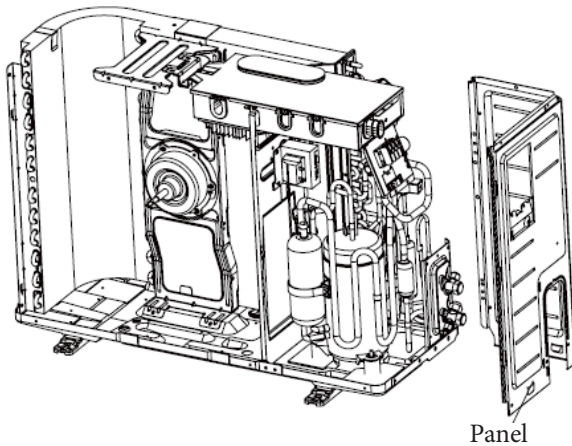

11. Remove fan motor and support

Remove the 4 screws holding the motor, remove wire connector, then remove the two screws holding the motor support bracket

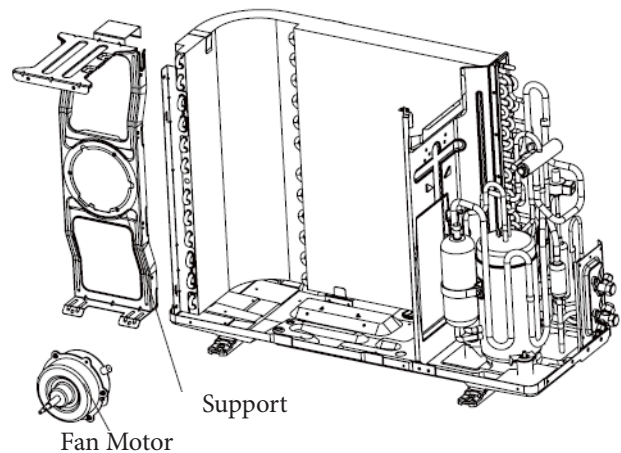

9. Remove electrical box assembly

Remove the screws holding the electrical box assembly and isolation board, loosen the bonding connection, then remove the wiring terminal, lift off box assembly.

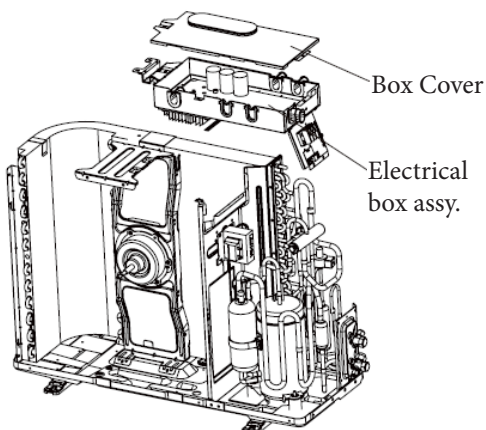

12. Remove mid-isolation board

Remove the screws connecting the mid-isolation board and condenser assembly

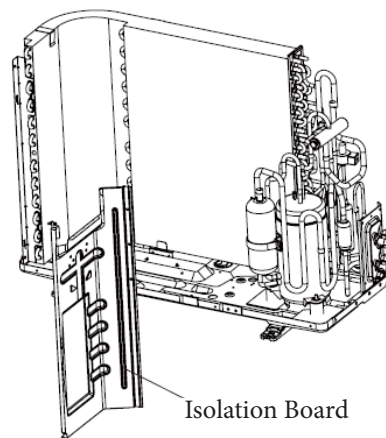

Disassembly of Outdoor Unit, continued

9,000 & 12,000 btuh **Warning - Wait 10 minutes after power is disconnected before starting disassembly.**

13. Remove 4-way valve assembly

Properly remove refrigerant charge, then remove valve by heating brazed joints and withdrawing pipe from valve.

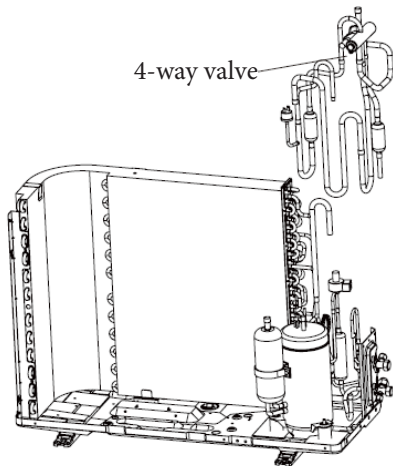

14. Remove compressor

Remove the three screws holding the compressor.

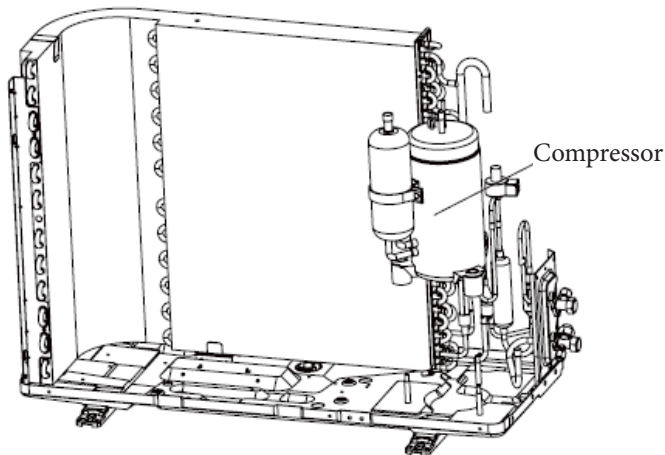

15. Remove valve assemblies and condensor

Remove the screws holding the condenser assembly, then remove the screws holding the two valve assemblies.

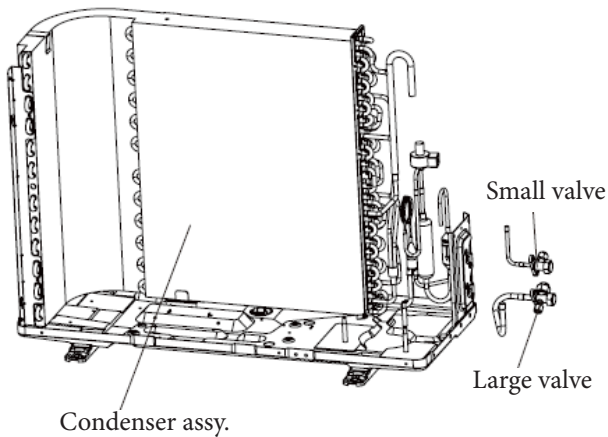

Disassembly of Outdoor Unit

18,000 btuh **Warning - Wait 10 minutes after power is disconnected before starting disassembly.**

1. Before Disassembly

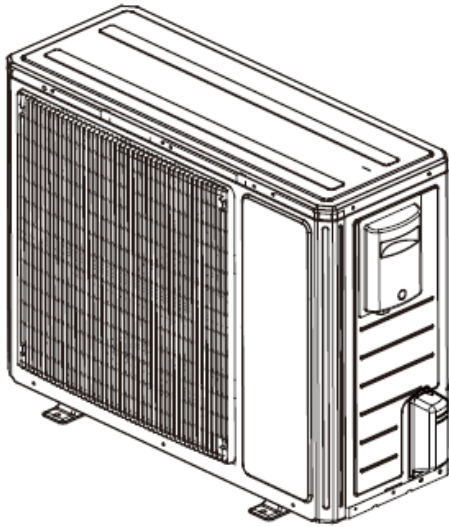

2. Remove handle and valve cover

Remove the screws connecting the handle and valve cover, then remove

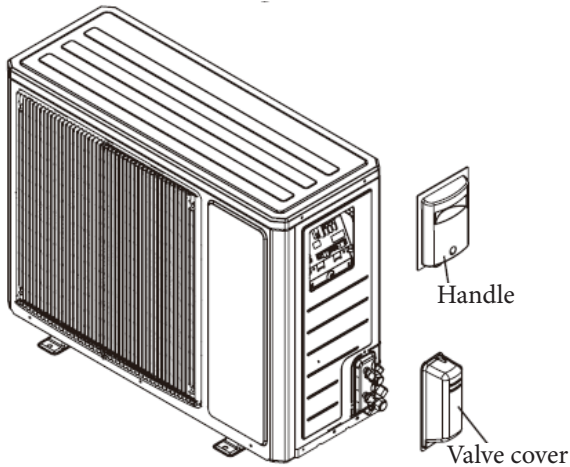

3. Remove top panel

Remove the screws connecting the top panel

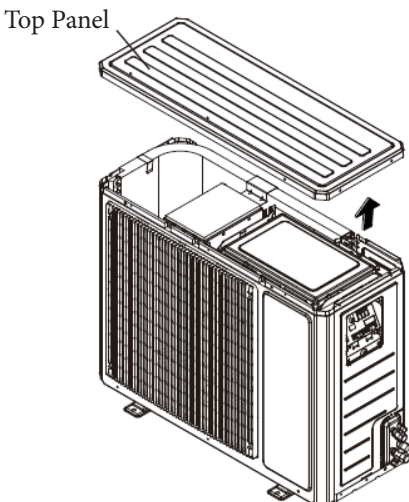

4. Remove front panel and grille

Remove the screws holding the grille and panel, remove the grille. Remove remaining screws holding the panel, pull panel upward, loosen the clamp on the right side, then rotate panel to the left and remove panel.

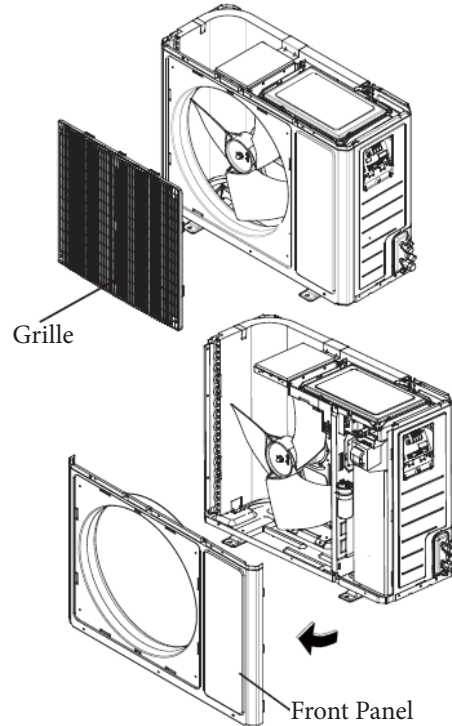

5. Remove right side panel.

Remove the screws holding the rear grille, remove the screws holding the right side panel, and valve support, pull it upward, then remove.

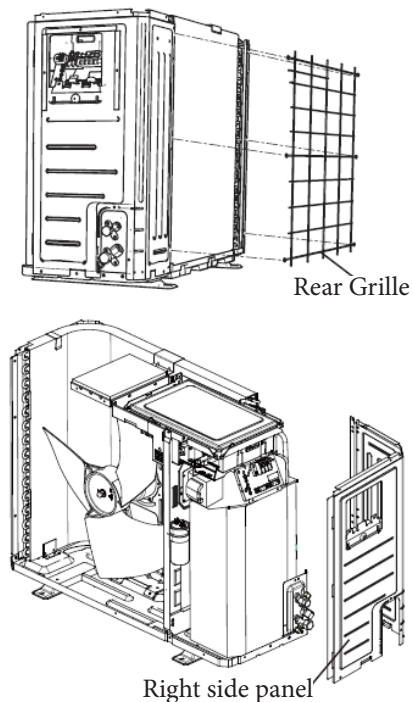

Disassembly of Outdoor Unit

18,000 btuh **Warning - Wait 10 minutes after power is disconnected before starting disassembly.**

6. Remove fan blade

Remove the bolt holding the blade then remove.

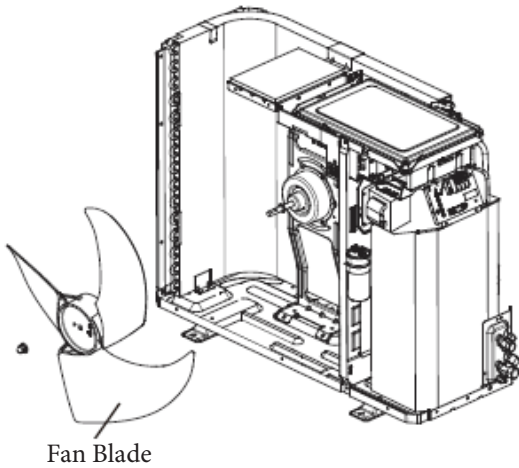

8. Remove sound proof barrier

Carefully remove barrier

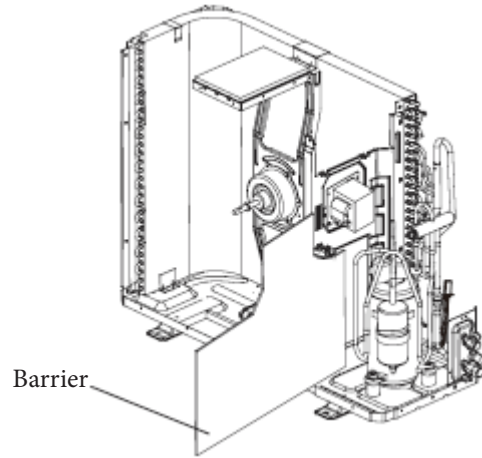

7. Remove electrical box assembly

Unplug the wire terminals of the compressor, motor, capacitor and reactor. Remove the bonding and ground screws, then remove screws holding box and remove box. Remove the screws holding the fire retardant box and remove,

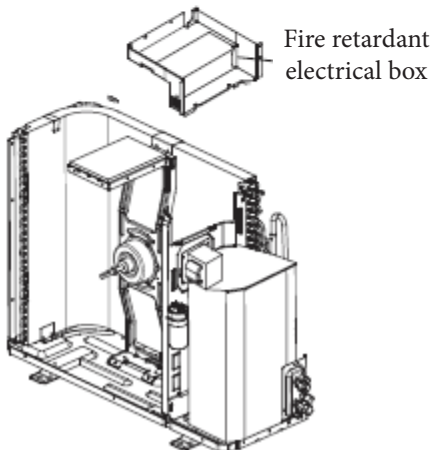
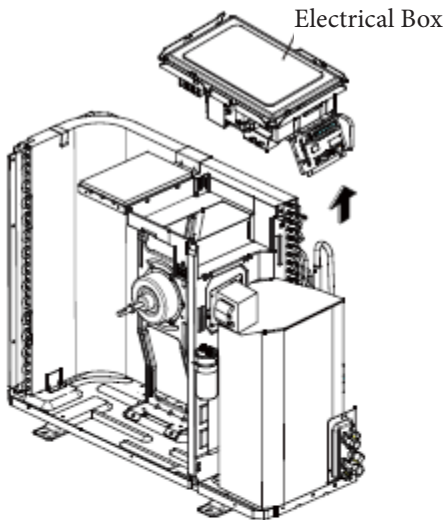

9. Remove isolation sheet

Remove screws holding sheet, then remove sheet

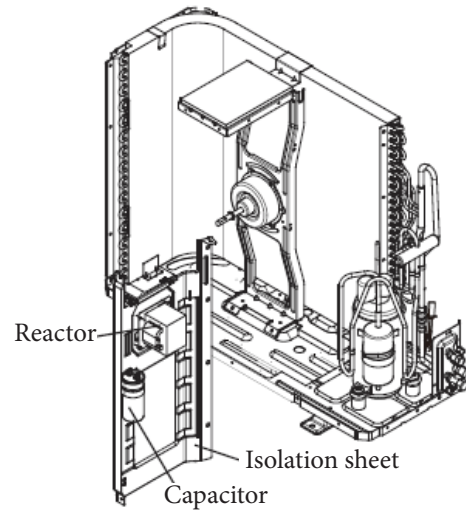

10. Remove refrigerant valves

Properly remove refrigerant. Protect valve assembly by wrapping valves with wet cloth, unsolder valves, then remove screws holding support. Remove screws holding valves, then remove valves.

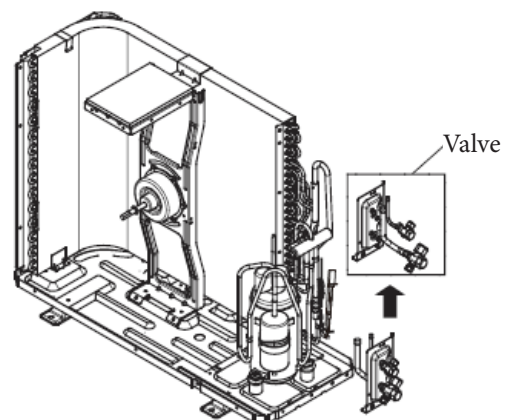

Disassembly of Outdoor Unit

18,000 btuh **Warning - Wait 10 minutes after power is disconnected before starting disassembly.**

11. Remove 4-way valve

Properly remove refrigerant charge, then remove valve by heating brazed joints and withdrawing pipe from valve.

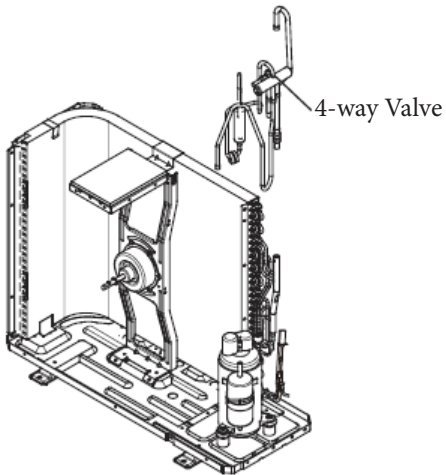

14. Remove condenser

Remove the screws holding the condenser assembly and chassis, then lift and remove

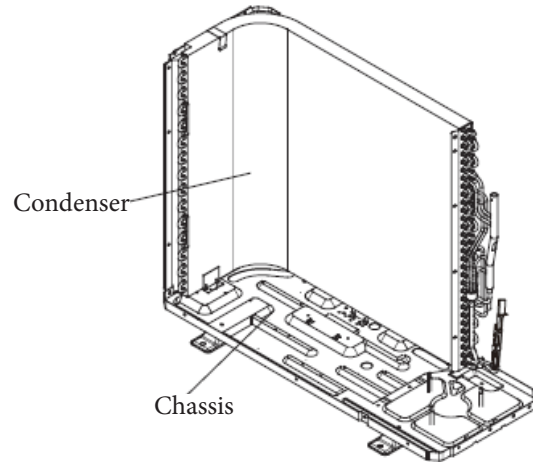

12. Remove compressor

Remove the three screws holding the compressor.

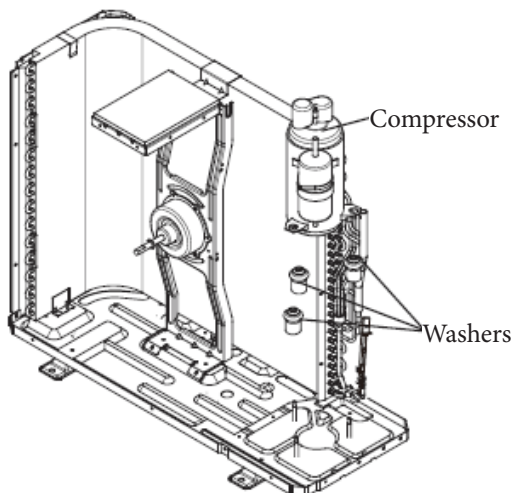

13. Remove fan motor and support

Remove the 4 screws holding the motor, remove wire connector, then remove the two screws holding the motor support bracket

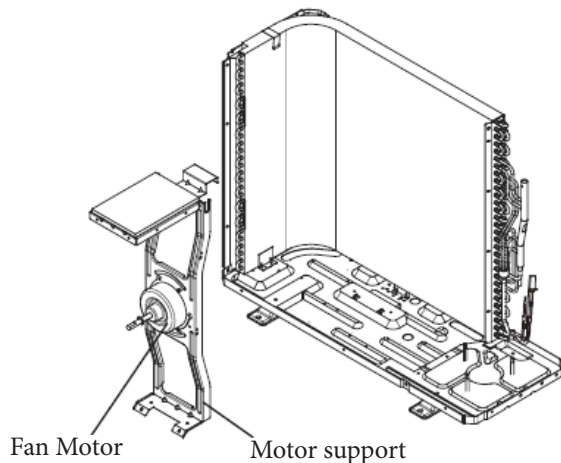

Disassembly of Outdoor Unit

24,000 btuh **Warning - Wait 10 minutes after power is disconnected before starting disassembly.**

7. Remove electrical box assembly

Remove the screws holding the top panel and side panels. Remove the screws holding the front panel and remove the panel

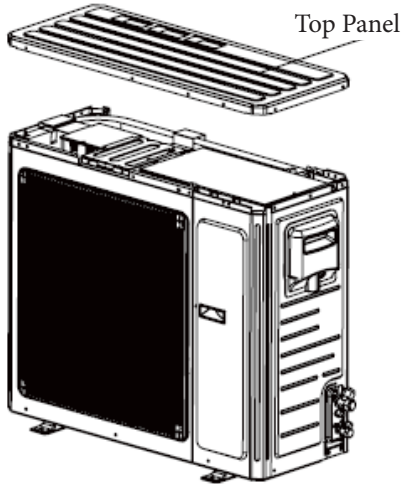

3. Remove back panel

Remove crews holding back panel from chassis and motor support

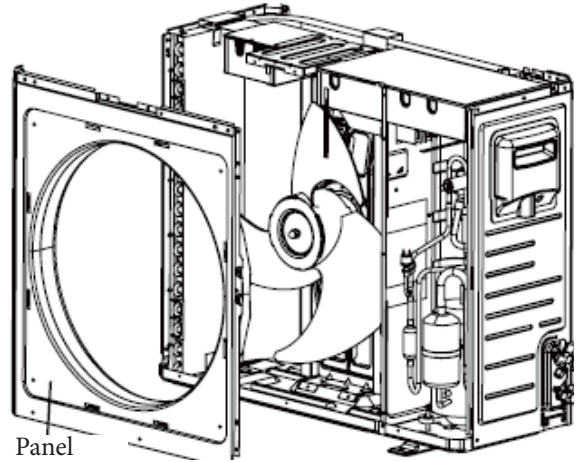

4. Remove grille guard

Remove the screws holding the grille guard, then remove guard

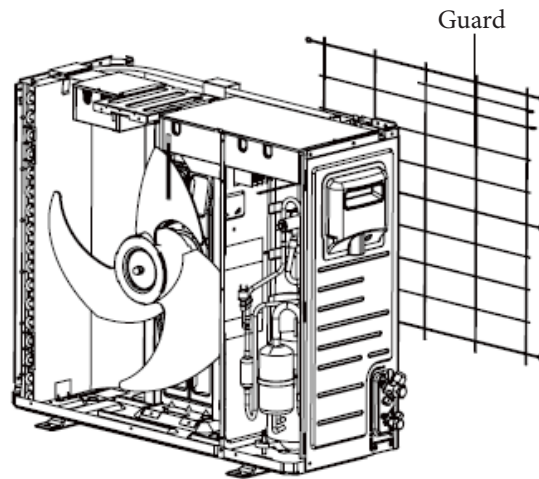
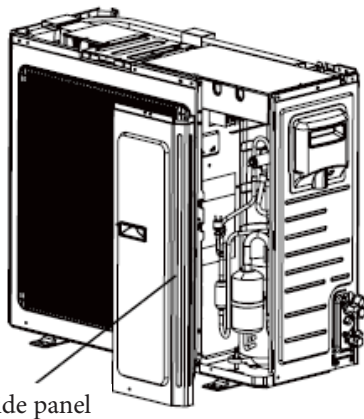

2. Remove front grille

Remove the screws holding the front grille

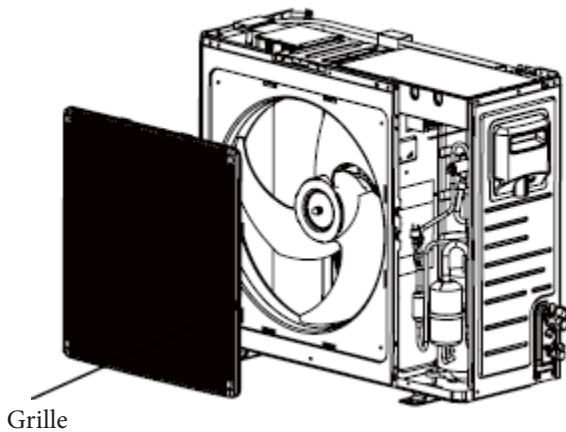

5. Remove handle

Remove the screws holding the handle

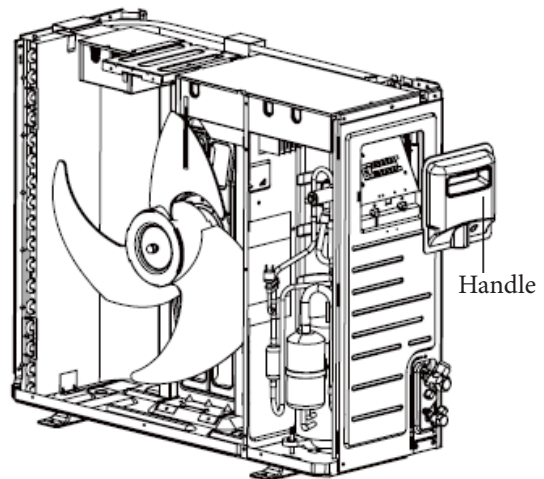

Disassembly of Outdoor Unit, continued

24,000 btuh **Warning - Wait 10 minutes after power is disconnected before starting disassembly.**

6. Remove right side panel

Remove screws holding right side panel from chassis, valve support and condenser, then remove panel

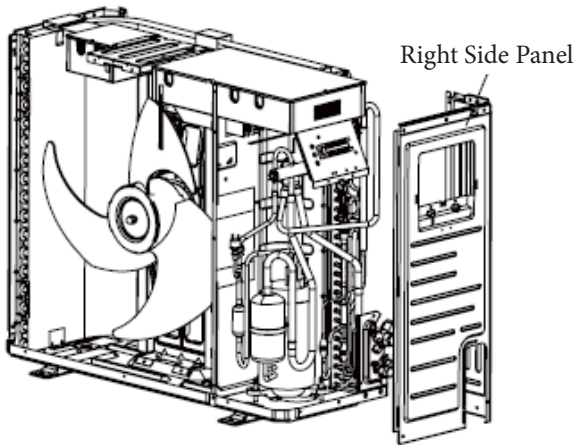

7a. Remove electrical box (secondary)

Remove screws holding secondary electrical box, then remove box

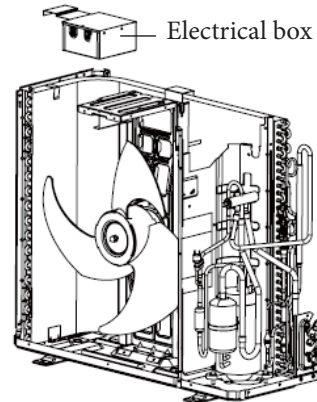

7. Remove electrical box assembly

Remove the screws holding electrical box, cut plastic wire tie, then unplug wire terminals.

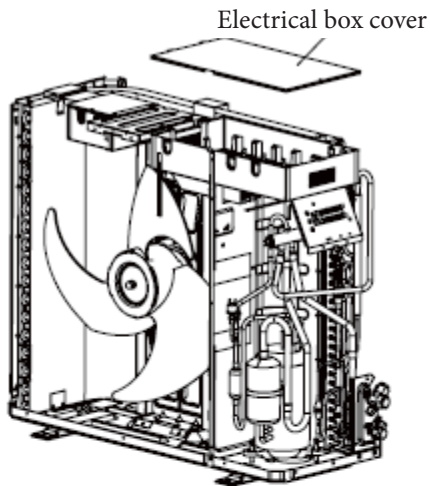

8. Remove left side panel

Remove the screws holding the left side panel and chassis, then remove panel

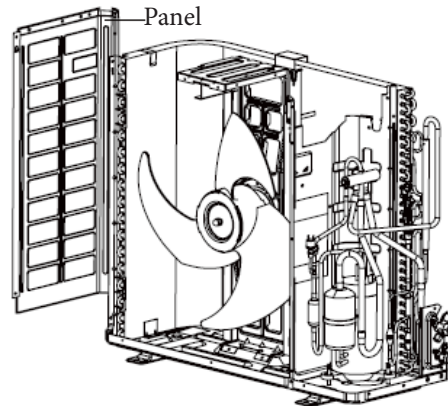

9. Remove fan blade

Remove the nuts on the blade, then pull fan blade off

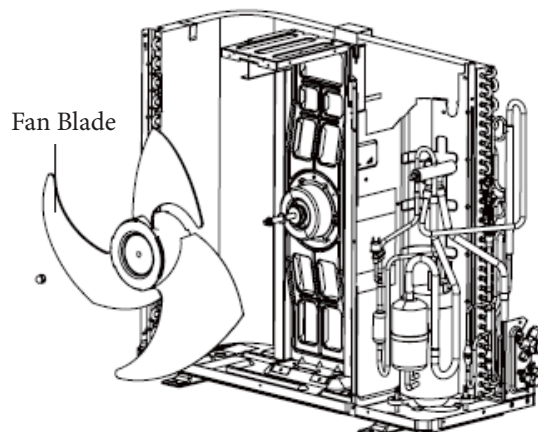
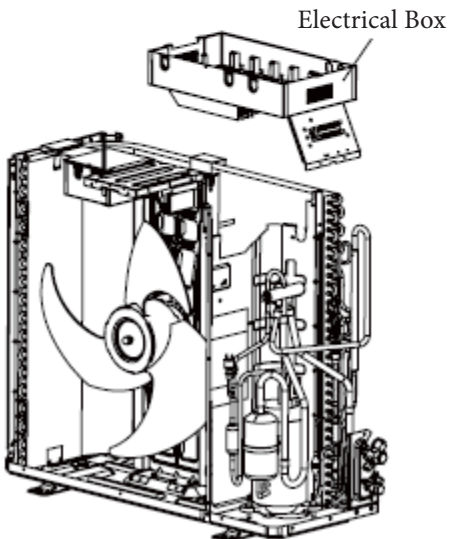

Disassembly of Outdoor Unit, continued

24,000 btuh **Warning - Wait 10 minutes after power is disconnected before starting disassembly.**

10. Remove motor and support

Remove the screws holding the motor, remove wire terminals, then remove the motor. Remove the screws holding the motor support, then remove the motor support

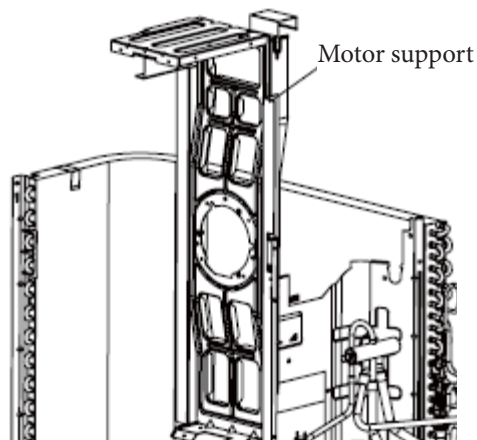
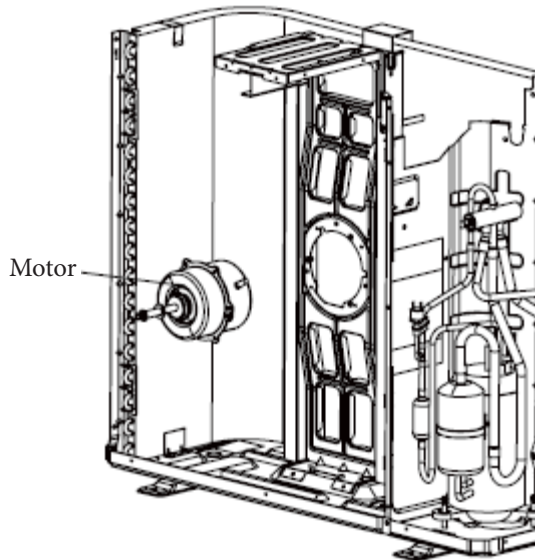

11. Remove 4-way valve

Properly remove the refrigerant, unsolder the pipes from the valve assembly

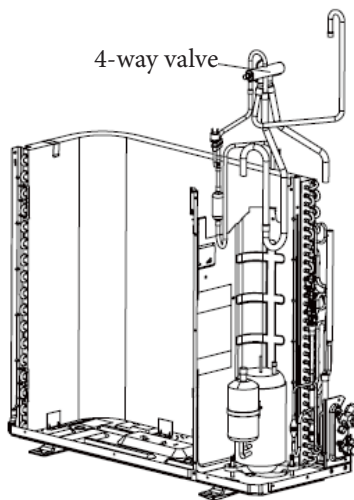

12. Remove gas and liquid valves

Remove the screws holding the valve sub-assembly. Remove any refrigerant in system. Wrap valve to prevent damage from heat. Unsolder the pipes from the valve, then remove valves.

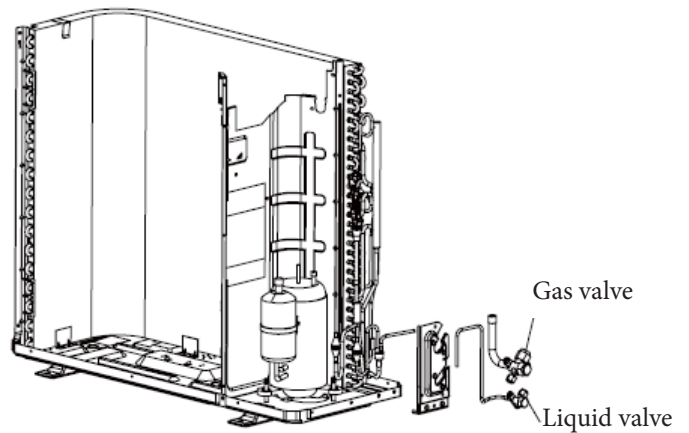

13. Remove compressor

Remove bolts from feet of compressor, then remove compressor

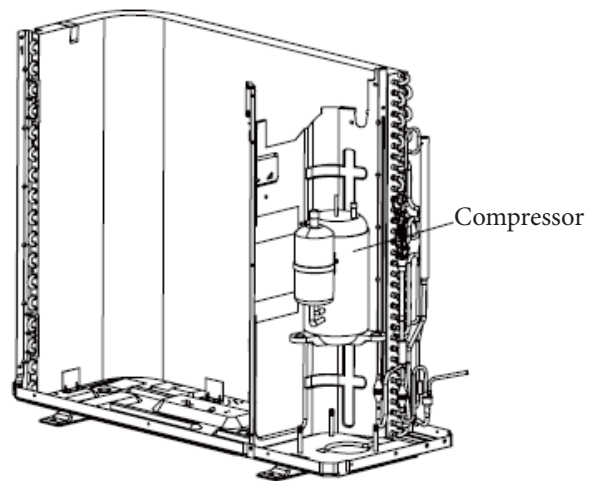

14. Remove isolation sheet

Remove the screws holding the isolation sheet from the condenser and chassis, then remove sheet

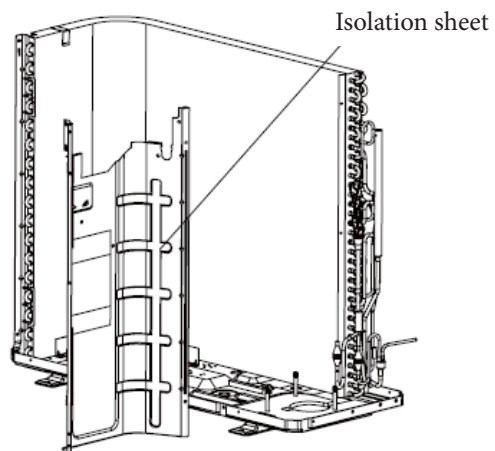

Disassembly of Outdoor Unit, continued

24,000 btuh **Warning - Wait 10 minutes after power is disconnected before starting disassembly.**

15. Remove condenser support plate

Remove the screws holding support plate, then remove plate

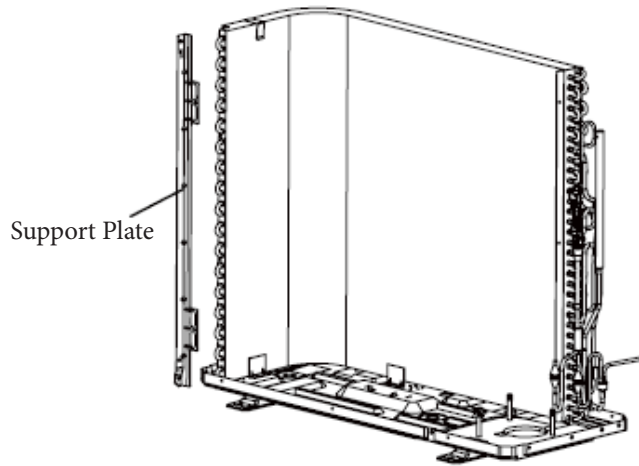

16. Remove chassis and condenser

Pull condenser upward to remove

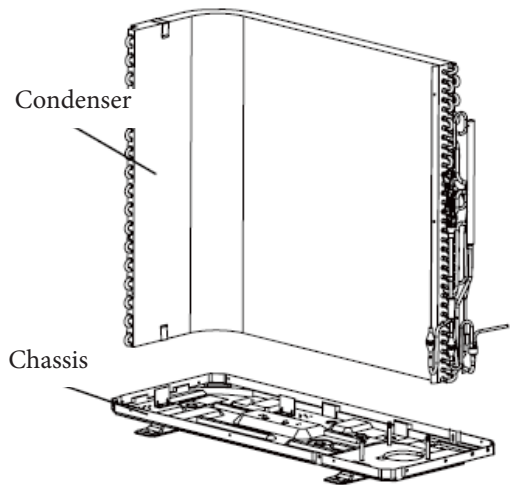

Appendix 1: Resistance Table of Ambient Temperature Sensor for Indoor and Outdoor Units (15K)

Temp (°C)	Temp (°F)	Resistance (kΩ)		Temp (°C)	Temp (°F)	Resistance (kΩ)		Temp (°C)	Temp (°F)	Resistance (kΩ)
-19	-2.2	138.1		33	91.4	10.63		85	185.0	1.594
-18	-0.4	128.6		34	93.2	10.2		86	186.8	1.544
-17	1.4	121.6		35	95.0	9.779		87	188.6	1.497
-16	3.2	115		36	96.8	9.382		88	190.4	1.451
-15	5.0	108.7		37	98.6	9.003		89	192.2	1.408
-14	6.8	102.9		38	100.4	8.642		90	194.0	1.363
-13	8.6	97.4		39	102.2	8.297		91	195.8	1.322
-12	10.4	92.22		40	104.0	7.967		92	197.6	1.282
-11	12.2	87.35		41	105.8	7.653		93	199.4	1.244
-10	14.0	82.75		42	107.6	7.352		94	201.2	1.207
-9	15.8	78.43		43	109.4	7.065		95	203.0	1.171
-8	17.6	74.35		44	111.2	6.791		96	204.8	1.136
-7	19.4	70.5		45	113.0	6.529		97	206.6	1.103
-6	21.2	66.88		46	114.8	6.278		98	208.4	1.071
-5	23.0	63.46		47	116.6	6.038		99	210.2	1.039
-4	24.8	60.23		48	118.4	5.809		100	212.0	1.009
-3	26.6	57.18		49	120.2	5.589		101	213.8	0.98
-2	28.4	54.31		50	122.0	5.379		102	215.6	0.952
-1	30.2	51.59		51	123.8	5.197		103	217.4	0.925
0	32.0	49.02		52	125.6	4.986		104	219.2	0.898
1	33.8	46.6		53	127.4	4.802		105	221.0	0.873
2	35.6	44.31		54	129.2	4.625		106	222.8	0.848
3	37.4	42.14		55	131.0	4.456		107	224.6	0.825
4	39.2	40.09		56	132.8	4.294		108	226.4	0.802
5	41.0	38.15		57	134.6	4.139		109	228.2	0.779
6	42.8	36.32		58	136.4	3.99		110	230.0	0.758
7	44.6	34.58		59	138.2	3.848		111	231.8	0.737
8	46.4	32.94		60	140.0	3.711		112	233.6	0.717
9	48.2	31.38		61	141.8	3.579		113	235.4	0.697

Appendix 1: Resistance Table of Ambient Temperature Sensor for Indoor and Outdoor Units (15K)

Temp (°C)	Temp (°F)	Resistance (kΩ)		Temp (°C)	Temp (°F)	Resistance (kΩ)		Temp (°C)	Temp (°F)	Resistance (kΩ)
10	50.0	29.9		62	143.6	3.454		114	237.2	0.678
11	51.8	28.51		63	145.4	3.333		115	239.0	0.66
12	53.6	27.18		64	147.2	3.217		116	240.8	0.642
13	55.4	25.92		65	149.0	3.105		117	242.6	0.625
14	57.2	24.73		66	150.8	2.998		118	244.4	0.608
15	59.0	23.6		67	152.6	2.896		119	246.2	0.592
16	60.8	22.53		68	154.4	2.797		120	248.0	0.577
17	62.6	21.51		69	156.2	2.702		121	249.8	0.561
18	64.4	20.54		70	158.0	2.611		122	251.6	0.547
19	66.2	19.63		71	159.8	2.523		123	253.4	0.532
20	68.0	18.75		72	161.6	2.439		124	255.2	0.519
21	69.8	17.93		73	163.4	2.358		125	257.0	0.505
22	71.6	17.14		74	165.2	2.28		126	258.8	0.492
23	73.4	16.39		75	167.0	2.206		127	260.6	0.48
24	75.2	15.68		76	168.8	2.133		128	262.4	0.467
25	77.0	15		77	170.6	2.064		129	264.2	0.456
26	78.8	14.36		78	172.4	1.997		130	266.0	0.44
27	80.6	13.74		79	174.2	1.933		131	267.8	0.433
28	82.4	13.16		80	176.0	1.871		132	269.6	0.422
29	84.2	12.6		81	177.8	1.811		133	271.4	0.412
30	86.0	12.07		82	179.6	1.754		134	273.2	0.401
31	87.8	11.57		83	181.4	1.699		135	275.0	0.391

Appendix 2: Resistance Table of Outdoor and Indoor Tube Temperature Sensors (20K)

Temp (°C)	Temp (°F)	Resistance (kΩ)		Temp (°C)	Temp (°F)	Resistance (kΩ)		Temp (°C)	Temp (°F)	Resistance (kΩ)
-19	-2.2	181.4		33	91.4	14.18		85	185.0	2.125
-18	-0.4	171.4		34	93.2	13.59		86	186.8	2.059
-17	1.4	162.1		35	95.0	13.04		87	188.6	1.996
-16	3.2	153.3		36	96.8	12.51		88	190.4	1.934
-15	5.0	145		37	98.6	12		89	192.2	1.875
-14	6.8	137.2		38	100.4	11.52		90	194.0	1.818
-13	8.6	129.9		39	102.2	11.06		91	195.8	1.736
-12	10.4	123		40	104.0	10.62		92	197.6	1.71
-11	12.2	116.5		41	105.8	10.2		93	199.4	1.658
-10	14.0	110.3		42	107.6	9.803		94	201.2	1.609
-9	15.8	104.6		43	109.4	9.42		95	203.0	1.561
-8	17.6	99.13		44	111.2	9.054		96	204.8	1.515
-7	19.4	94		45	113.0	8.705		97	206.6	1.47
-6	21.2	89.17		46	114.8	8.37		98	208.4	1.427
-5	23.0	84.61		47	116.6	8.051		99	210.2	1.386
-4	24.8	80.31		48	118.4	7.745		100	212.0	1.346
-3	26.6	76.24		49	120.2	7.453		101	213.8	1.307
-2	28.4	72.41		50	122.0	7.173		102	215.6	1.269
-1	30.2	68.79		51	123.8	6.905		103	217.4	1.233
0	32.0	65.37		52	125.6	6.648		104	219.2	1.198
1	33.8	62.13		53	127.4	6.403		105	221.0	1.164
2	35.6	59.08		54	129.2	6.167		106	222.8	1.131
3	37.4	56.19		55	131.0	5.942		107	224.6	1.099
4	39.2	53.46		56	132.8	5.726		108	226.4	1.069
5	41.0	50.87		57	134.6	5.519		109	228.2	1.039
6	42.8	48.42		58	136.4	5.32		110	230.0	1.01
7	44.6	46.11		59	138.2	5.13		111	231.8	0.983
8	46.4	43.92		60	140.0	4.948		112	233.6	0.956
9	48.2	41.84		61	141.8	4.773		113	235.4	0.93

Appendix 2: Resistance Table of Outdoor and Indoor Tube Temperature Sensors (20K)

Temp (°C)	Temp (°F)	Resistance (kΩ)		Temp (°C)	Temp (°F)	Resistance (kΩ)		Temp (°C)	Temp (°F)	Resistance (kΩ)
10	50.0	39.87		62	143.6	4.605		114	237.2	0.904
11	51.8	38.01		63	145.4	4.443		115	239.0	0.88
12	53.6	36.24		64	147.2	4.289		116	240.8	0.856
13	55.4	34.57		65	149.0	4.14		117	242.6	0.833
14	57.2	32.98		66	150.8	3.998		118	244.4	0.811
15	59.0	31.47		67	152.6	3.861		119	246.2	0.77
16	60.8	30.04		68	154.4	3.729		120	248.0	0.769
17	62.6	28.68		69	156.2	3.603		121	249.8	0.746
18	64.4	27.39		70	158.0	3.481		122	251.6	0.729
19	66.2	26.17		71	159.8	3.364		123	253.4	0.71
20	68.0	25.01		72	161.6	3.252		124	255.2	0.692
21	69.8	23.9		73	163.4	3.144		125	257.0	0.674
22	71.6	22.85		74	165.2	3.04		126	258.8	0.658
23	73.4	21.85		75	167.0	2.94		127	260.6	0.64
24	75.2	20.9		76	168.8	2.844		128	262.4	0.623
25	77.0	20		77	170.6	2.752		129	264.2	0.607
26	78.8	19.14		78	172.4	2.663		130	266.0	0.592
27	80.6	18.13		79	174.2	2.577		131	267.8	0.577
28	82.4	17.55		80	176.0	2.495		132	269.6	0.563
29	84.2	16.8		81	177.8	2.415		133	271.4	0.549
30	86.0	16.1		82	179.6	2.339		134	273.2	0.535
31	87.8	15.43		83	181.4	2.265		135	275.0	0.521
32	89.6	14.79		84	183.2	2.194		136	276.8	0.509

Appendix 3: Resistance Table of Outdoor Discharge Temperature Sensor (50K)

Temp (°C)	Temp (°F)	Resistance (kΩ)		Temp (°C)	Temp (°F)	Resistance (kΩ)		Temp (°C)	Temp (°F)	Resistance (kΩ)
-29	-20.2	853.5		23	73.4	53.74		75	167.0	7.224
-28	-18.4	799.8		24	75.2	51.41		76	168.8	6.998
-27	-16.6	750		25	77.0	49.19		77	170.6	6.761
-26	-14.8	703.8		26	78.8	47.08		78	172.4	6.542
-25	-13.0	660.8		27	80.6	45.07		79	174.2	6.331
-24	-11.2	620.8		28	82.4	43.16		80	176.0	6.129
-23	-9.4	580.6		29	84.2	41.34		81	177.8	5.933
-22	-7.6	548.9		30	86.0	39.61		82	179.6	5.746
-21	-5.8	516.6		31	87.8	37.96		83	181.4	5.565
-20	-4.0	486.5		32	89.6	36.38		84	183.2	5.39
-19	-2.2	458.3		33	91.4	34.88		85	185.0	5.22
-18	-0.4	432		34	93.2	33.45		86	186.8	5.06
-17	1.4	407.4		35	95.0	32.09		87	188.6	4.904
-16	3.2	384.5		36	96.8	30.79		88	190.4	4.754
-15	5.0	362.9		37	98.6	29.54		89	192.2	4.609
-14	6.8	342.8		38	100.4	28.36		90	194.0	4.469
-13	8.6	323.9		39	102.2	27.23		91	195.8	4.334
-12	10.4	306.2		40	104.0	26.15		92	197.6	4.204
-11	12.2	289.6		41	105.8	25.11		93	199.4	4.079
-10	14.0	274		42	107.6	24.13		94	201.2	3.958
-9	15.8	259.3		43	109.4	23.19		95	203.0	3.841
-8	17.6	245.6		44	111.2	22.29		96	204.8	3.728
-7	19.4	232.6		45	113.0	21.43		97	206.6	3.619
-6	21.2	220.5		46	114.8	20.6		98	208.4	3.514
-5	23.0	209		47	116.6	19.81		99	210.2	3.413
-4	24.8	198.3		48	118.4	19.06		100	212.0	3.315
-3	26.6	199.1		49	120.2	18.34		101	213.8	3.22
-2	28.4	178.5		50	122.0	17.65		102	215.6	3.129
-1	30.2	169.5		51	123.8	16.99		103	217.4	3.04
0	32.0	161		52	125.6	16.36		104	219.2	2.955
1	33.8	153		53	127.4	15.75		105	221.0	2.872
2	35.6	145.4		54	129.2	15.17		106	222.8	2.792
3	37.4	138.3		55	131.0	14.62		107	224.6	2.715
4	39.2	131.5		56	132.8	14.09		108	226.4	2.64

Appendix 3: Resistance Table of Outdoor Discharge Temperature Sensor (50K)

Temp (°C)	Temp (°F)	Resistance (kΩ)		Temp (°C)	Temp (°F)	Resistance (kΩ)		Temp (°C)	Temp (°F)	Resistance (kΩ)
5	41.0	125.1		57	134.6	13.58		109	228.2	2.568
6	42.8	119.1		58	136.4	13.09		110	230.0	2.498
7	44.6	113.4		59	138.2	12.62		111	231.8	2.431
8	46.4	108		60	140.0	12.17		112	233.6	2.365
9	48.2	102.8		61	141.8	11.74		113	235.4	2.302
10	50.0	98		62	143.6	11.32		114	237.2	2.241
11	51.8	93.42		63	145.4	10.93		115	239.0	2.182
12	53.6	89.07		64	147.2	10.54		116	240.8	2.124
13	55.4	84.95		65	149.0	10.18		117	242.6	2.069
14	57.2	81.05		66	150.8	9.827		118	244.4	2.015
15	59.0	77.35		67	152.6	9.489		119	246.2	1.963
16	60.8	73.83		68	154.4	9.165		120	248.0	1.912
17	62.6	70.5		69	156.2	8.854		121	249.8	1.863
18	64.4	67.34		70	158.0	8.555		122	251.6	1.816
19	66.2	64.33		71	159.8	8.268		123	253.4	1.77
20	68.0	61.48		72	161.6	7.991		124	255.2	1.725
21	69.8	58.77		73	163.4	7.726		125	257.0	1.682
22	71.6	56.19		74	165.2	7.47		126	258.8	1.64

